

# TKK-2Y

## THERMOSTATIC STEAM TRAP

### GENERAL FEATURES

Ayvaz TKK-2Y 's capsule follows the steam curves with constantly and it helps to drain condensate and non condensable gases. The resistance of the thermostatic trap, which is not affected by the water hammer, is also highly resistant to corrosion.

The only difference from the other Ayvaz thermostatic trap in the TKK-2Y type is that the strainer is of type "Y". The "Y" type of trapped traps are made of forged steel and the other inner part is stainless steel, providing cleanliness for many applications. Like all Ayvaz thermostatic traps, the TKK-2Y product also includes one of three different capsules, depending on application conditions.

"S" type capsules are used in standard productions. The entire trap can be supplied as a spare part. At the same time, the ball inside the seat acts as a check valve at the high back pressure in the system, preventing the condensate from mixing into the steam line.

Ayvaz TKK-2Y Thermostatic Traps can be connected to the pipeline in every position for efficient and long-term operation. Proper isolation valves must be installed to ensure the maintenance and replacement of the trap is safe.

Proper isolation valves must be installed to ensure the maintenance and replacement of the trap is safe.

**Product Material:**  
Body and Cover: Forged Steel  
Inner Parts: AISI 304 Stainless Steel

**Connection:**  
Threaded, Welding End, Socket and Flanged

**Nominal Diameter:**  
DN15 (1/2" ) - DN25 (1" )

**Pressure Value:**  
Max. 32 bar

**Working Temperature:**  
Max. Working Temperature 250 °C

**Applications:**  
-Tracing Line  
-Drying Units  
-Pressing Units  
-Steam Jacket Pipes  
-Irons

**Installation:**  
The thermostatic trap, which can work in every position, can be connected to the pipeline at every position.

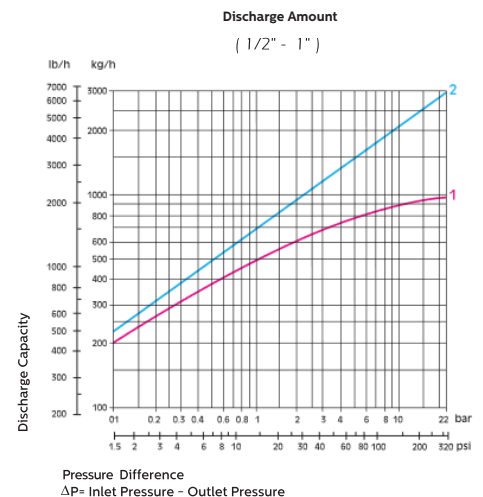

#### Red Chart

Steam saturation temperature max. 10 °C below the condensate drain;

#### Blue Chart

Cold condensate drain at 20 °C

TECHNICAL SPECIFICATIONS			
Connect. Type	Flanged	Threaded	Weld. End
Di.a.(mm)	15-20-25	1/2-3/4-1"	1/2-3/4-1"
Weight(kg)	3,4-4,1-4,5	1,8-1,7-1,6	1,9-1,9-1,9

# TKK-2Y THERMOSTATIC STEAM TRAP

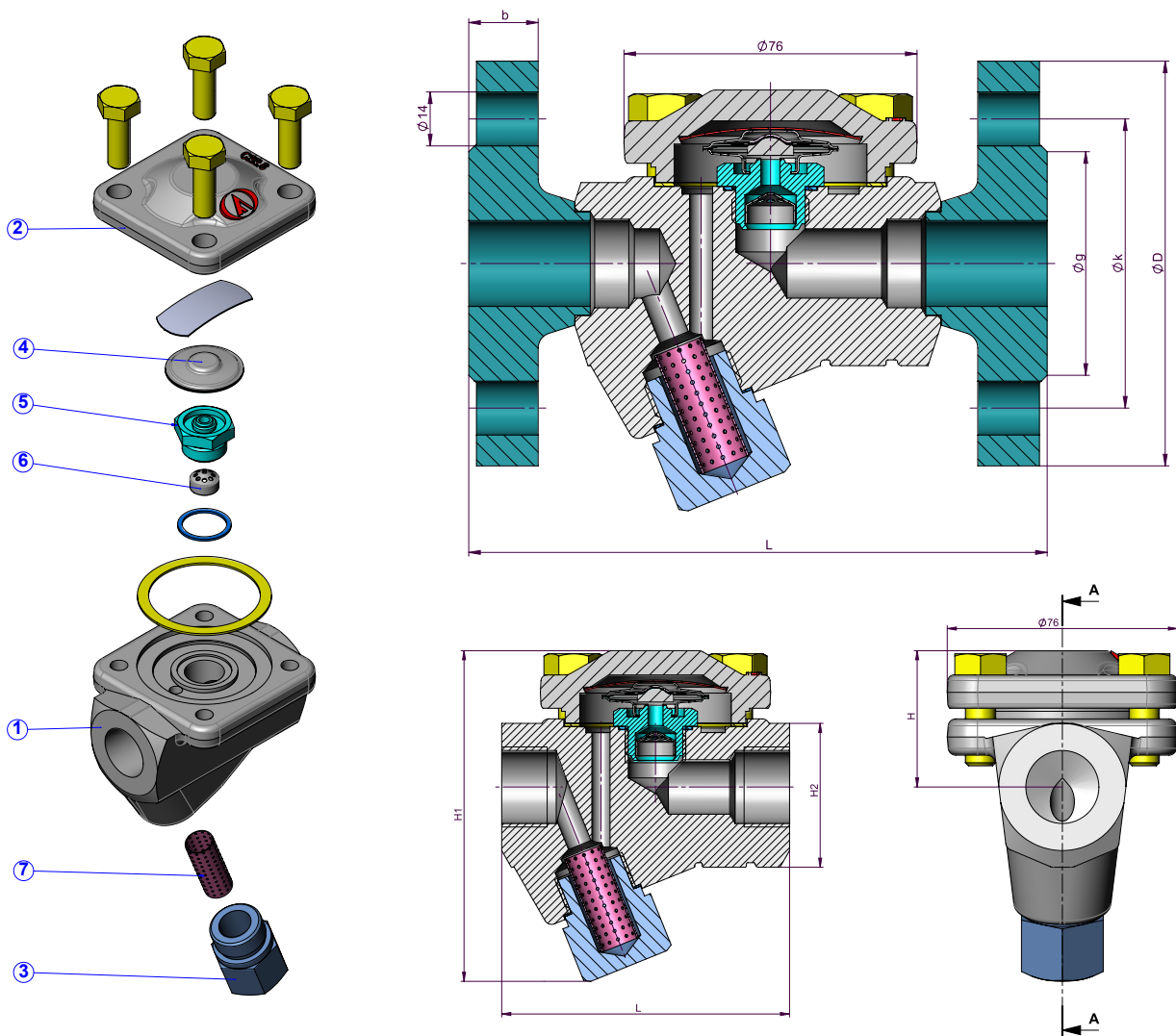

DIMENSIONS (mm)							
Dia.	L - L1	H - H1 - H2	D	b	k	g	Holes
15	150 - 95	45 - 97 - 40	95	16	65	45	4
20	150 - 95	45 - 97 - 40	105	18	75	58	4
25	160 - 95	45 - 97 - 40	115	18	85	68	4

SPARE PARTS		
No	Part	Material
1	Body	Forged Steel
2	Cover	Forged Steel
3	Filter	Stainless Steel
4	Thermostatic Capsule	Hastelloy & Stainless Steel
5	Seat	Stainless Steel
6	Cover Bolts	DIN 40 CrMoV4 7
7	Check Valve	AISI 304