

CONCENTRIC LUG BUTTERFLY VALVE INITIAL RANGE CAST IRON BODY WITH STAINLESS STEEL DISC AND EPDM SEAT

Lug butterfly valve initial range for cold and hot water, sea water, demineralized water, alcohol, milk of lime, mercury, alcalins, hydroxid of soda.

Cast iron EN GJL-250 body, stainless steel disc and EPDM seat.

Between flanges PN10/PN16.

Handling possible with gearbox.

Thanks to the ISO 5211 plate, an actuator can be installed on the valve.



Painting color is actually changing for RAL5005



New painting



Old painting

- Size :** DN40 to DN600
- Connection :** Between flanges PN10/16
- Min Temperature :** -15°C
- Max Temperature :** +110°C (130°C temporarily)
- Max Pressure :** 16 Bars up to DN300, 10 bars over
- Specifications :** Long neck for isolation
Stainless steel disc
Vulcanised EPDM seat
ISO 5211 mounting pad

Materials : Cast iron EN GJL250 body, EPDM seat

CONCENTRIC LUG BUTTERFLY VALVE INITIAL RANGE CAST IRON BODY WITH STAINLESS STEEL DISC AND EPDM SEAT

SPECIFICATIONS :

- Long neck for isolation
- ISO 5211 mounting pad
- Lug type
- Between flanges PN10 or PN16 from DN 40 to DN 600
- Full crossing stem up to DN600
- 10 positions cranted lever, with locking device up to DN150
- Double PTFE gasket on stem up to DN600
- Stainless steel disc
- Epoxy painting RAL003 80 microns thickness, **painting color is actually changing for RAL5005**
- EPDM vulcanized seat

USE :

- Cold and hot water, sea water, demineralized water, alcohol, milk of lime, mercury, alcalins, hydroxid of soda
- Min and max Temperature Ts : - 15°C to + 110°C (130°C temporarily)
- Max Pressure Ps : 16 bars up to DN300, 10 bars over
- Can be used at the end of the pipe (10 bars maxi) with a counter flange installed at the end of the valve

FLOW COEFFICIENT Kv (M3 / h) :

DN		40	50	65	80	100	125	150	200	250	300	350	400	450	500	600
Opening angle	10°	0,04	0,05	0,09	0,17	0,26	0,43	0,68	1,7	2,6	3,4	5,1	6,8	9,4	11,9	18,8
	20°	2	3	5	8	15	25	38	76	129	200	288	396	525	675	1042
	30°	5	6	10	15	31	52	81	160	273	422	610	839	1101	1428	2207
	40°	10	13	21	33	67	113	175	348	592	914	1321	1817	2407	3095	4781
	50°	18	23	38	60	119	202	312	620	1055	1630	2355	3239	4289	5515	8521
	60°	30	38	64	99	196	334	516	1025	1746	2697	3897	5359	7097	9125	14098
	70°	48	60	102	156	310	529	817	1623	2764	4269	6167	8481	11232	14442	22312
	80°	72	90	152	235	466	793	1226	2434	4145	6403	9250	12720	16848	21662	33468
	90°	78	98	167	258	512	872	1347	2675	4555	7037	10165	13799	18514	23805	36778

TORQUE VALUES (Nm, without safety coefficient) :

We recommend a safety coefficient of 30% minimum to determinate the actuator.

DN	40	50	65	80	100	125	150	200	250	300	350	400	450	500	600
PN10	9	12	19	25	38	58	85	159	253	369	428	671	1001	1220	2221
PN16	10	13	21	26	42	65	95	175	277	536	-	-	-	-	-

CONCENTRIC LUG BUTTERFLY VALVE INITIAL RANGE CAST IRON BODY WITH STAINLESS STEEL DISC AND EPDM SEAT

PRESSURE / TEMPERATURE GRAPH (STEAM EXCLUDED) :

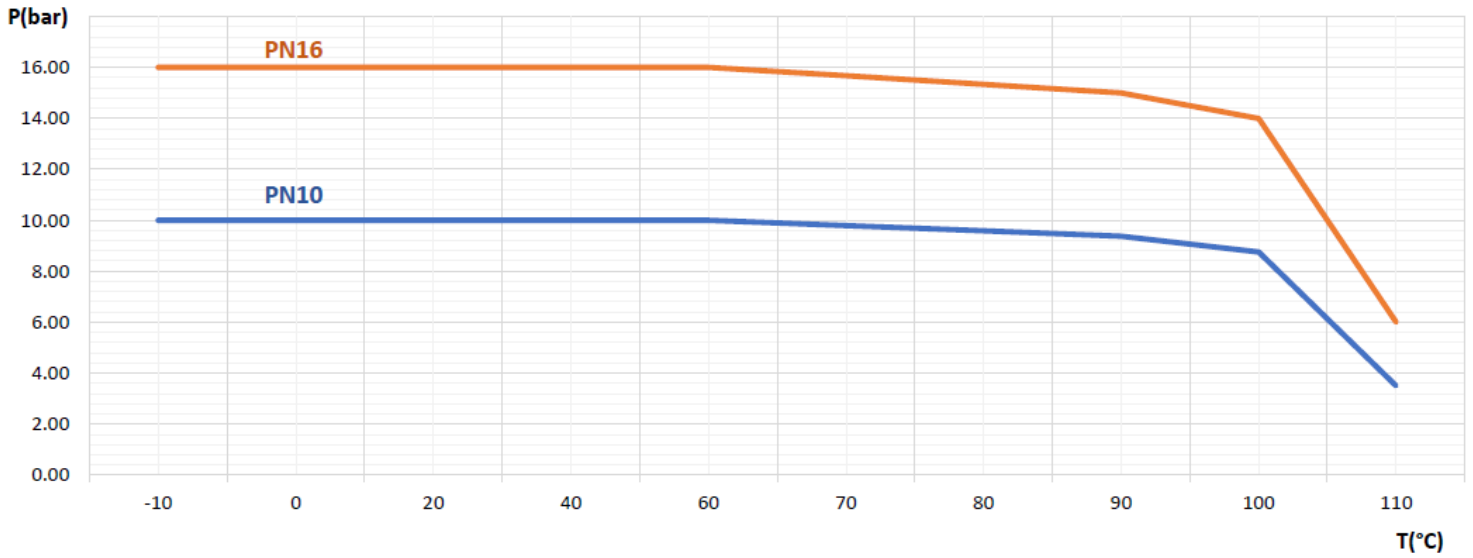

RANGE :

- With lever from DN40 to DN300
- With gearbox from DN350 to DN600
- Gearbox possible from DN40 to DN300 **Ref.1198**

CONCENTRIC LUG BUTTERFLY VALVE INITIAL RANGE CAST IRON BODY WITH STAINLESS STEEL DISC AND EPDM SEAT

MATERIALS DN 40 – 300 :

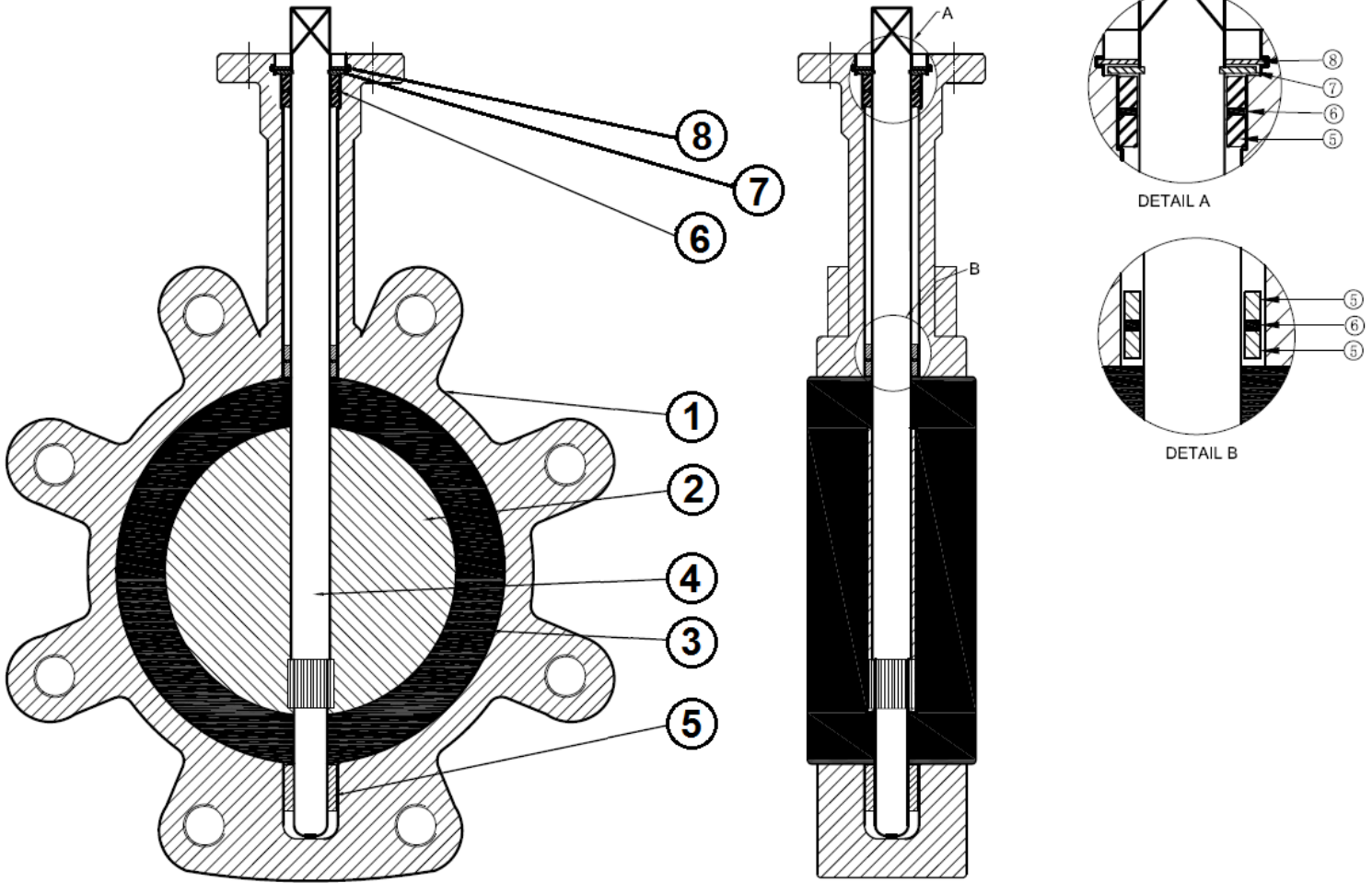

Item	Designation	Materials
1	Body	Cast iron EN GJL-250
2	Disc	ASTM A351 CF8M
3	Seat	EPDM
4	Stem	AISI 420
5	Bushing	PTFE
6	O ring	EPDM
7	Circlip	Steel
8	Circlip	Steel
	Lever	Aluminium

CONCENTRIC LUG BUTTERFLY VALVE INITIAL RANGE CAST IRON BODY WITH STAINLESS STEEL DISC AND EPDM SEAT

MATERIALS DN 350 :

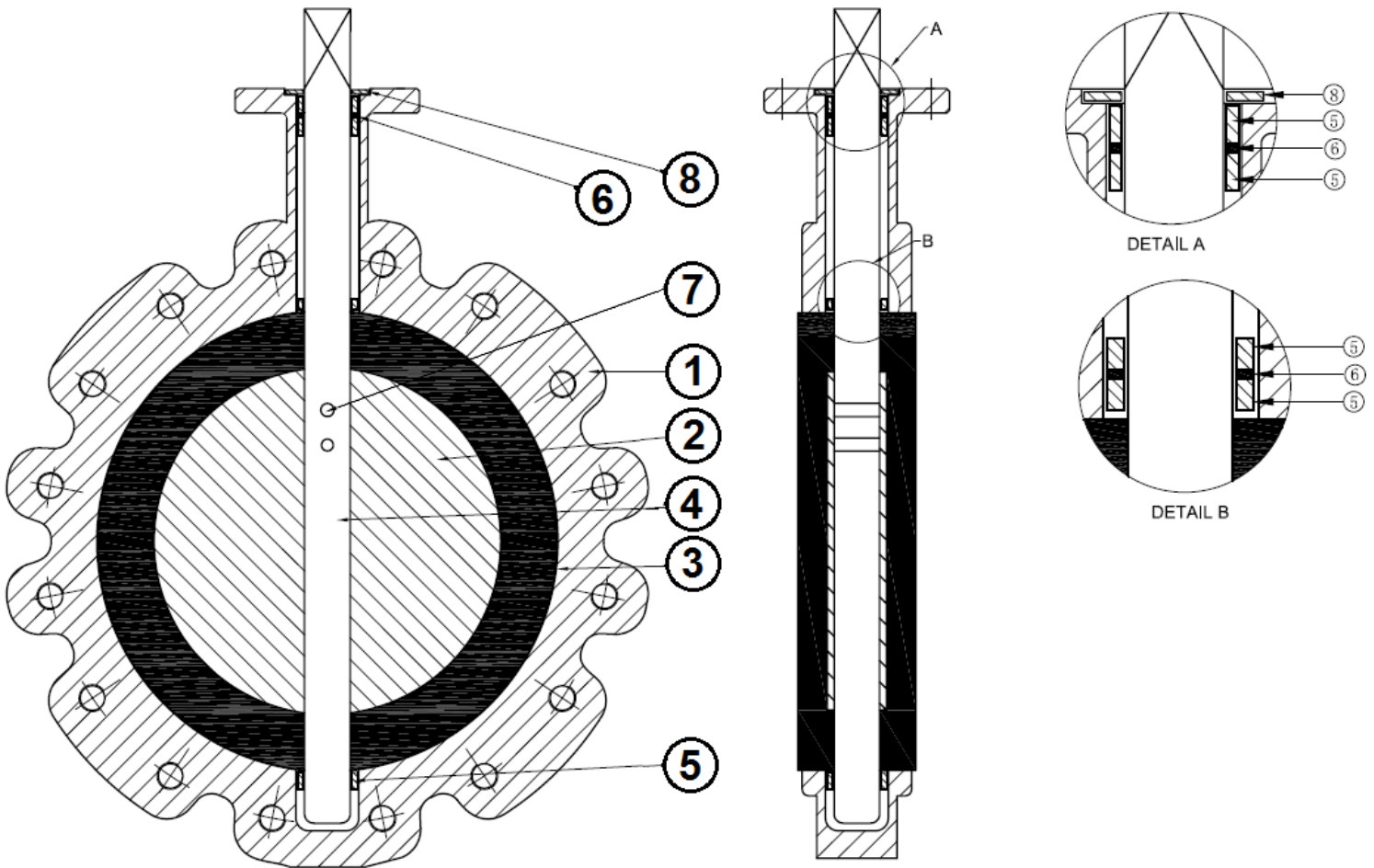

Item	Designation	Materials
1	Body	Cast iron EN GJL-250
2	Disc	ASTM A351 CF8M
3	Seat	EPDM
4	Stem	AISI 431
5	Bushing	PTFE
6	O ring	EPDM
7	Pin	AISI 316
8	Gasket	EPDM

CONCENTRIC LUG BUTTERFLY VALVE INITIAL RANGE CAST IRON BODY WITH STAINLESS STEEL DISC AND EPDM SEAT

MATERIALS DN 400-600 :

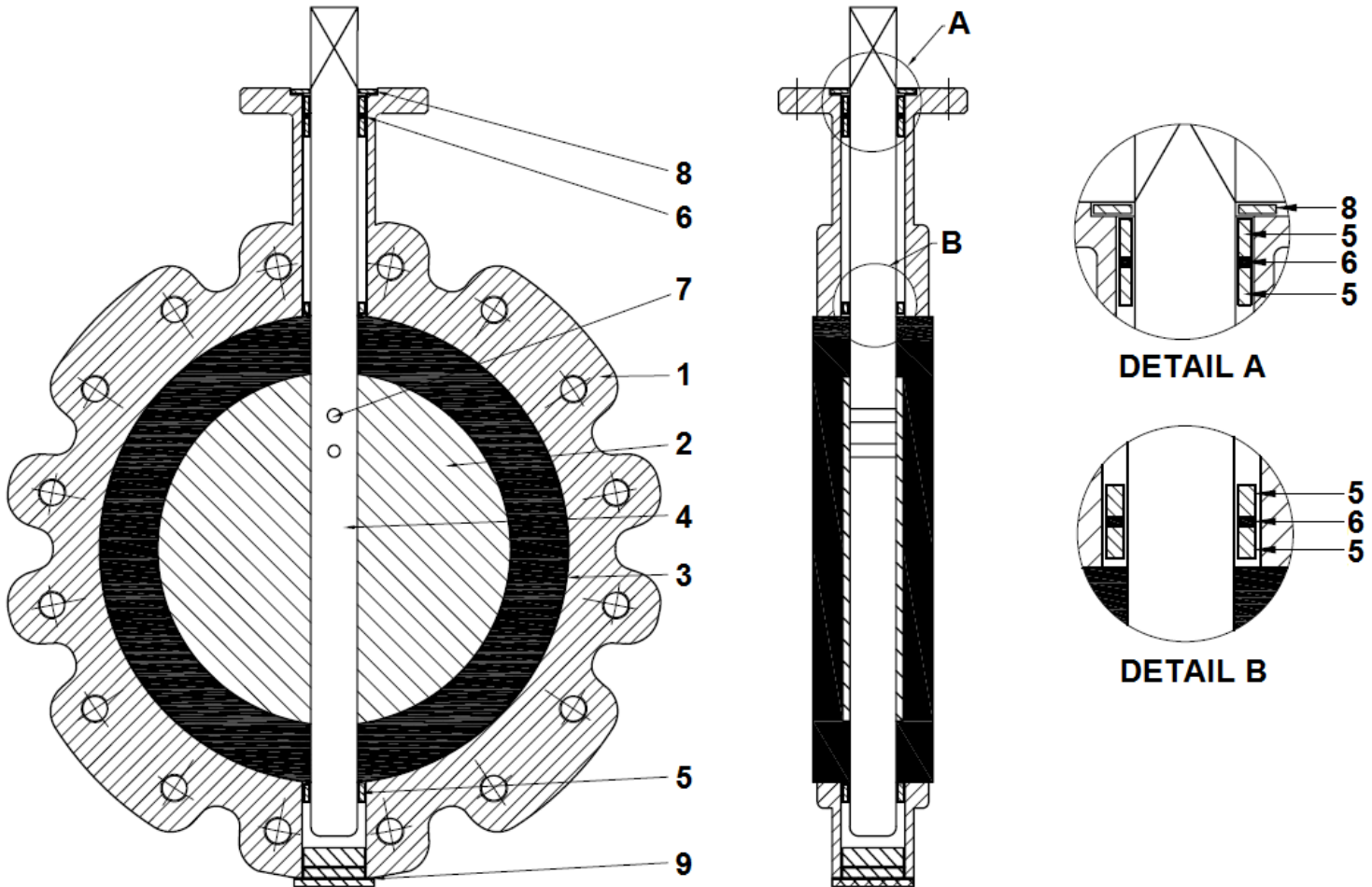

Item	Designation	Materials
1	Body	Cast iron EN GJL-250
2	Disc	ASTM A351 CF8M
3	Seat	EPDM
4	Stem	AISI 431
5	Bushing	PTFE
6	O ring	EPDM
7	Pin	AISI 316
8	Gasket	EPDM
9	Gasket	EPDM

CONCENTRIC LUG BUTTERFLY VALVE INITIAL RANGE CAST IRON BODY WITH STAINLESS STEEL DISC AND EPDM SEAT

MATERIALS GEARBOX DN40-450 :

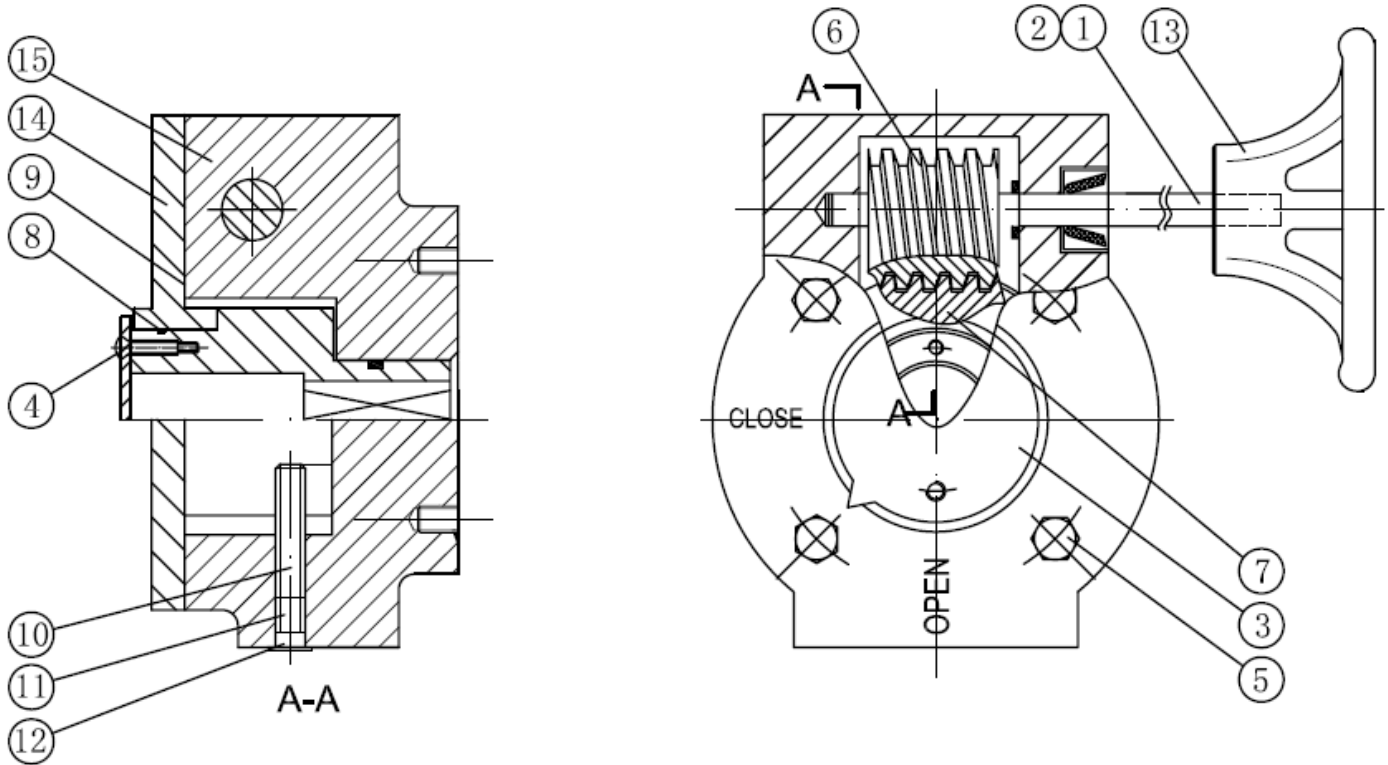

Item	Designation	Materials
1	Stem	Chromed steel
2	Pin	AISI 316
3	Indicator plate	Aluminium + NBR gasket
4	Indicator bolt, washer	AISI 316
5	Bolt, washer	AISI 316
6	Gear 1	Steel
7	Gear 2	Ductile iron EN GJS-400-15
8	O ring	NBR
9	Bonnet gasket	NBR
10	Internal set screw	Carbon steel
11	External set screw	AISI 316
12	Plastic cap	Plastic
13	Handwheel	Cast iron EN GJL-250 epoxy coating
14	Bonnet	Cast iron EN GJL-250 epoxy coating
15	Body	Cast iron EN GJL-250 epoxy coating
	Bolting to fix on valve	AISI 304

CONCENTRIC LUG BUTTERFLY VALVE INITIAL RANGE CAST IRON BODY WITH STAINLESS STEEL DISC AND EPDM SEAT

MATERIALS GEARBOX DN500-600 :

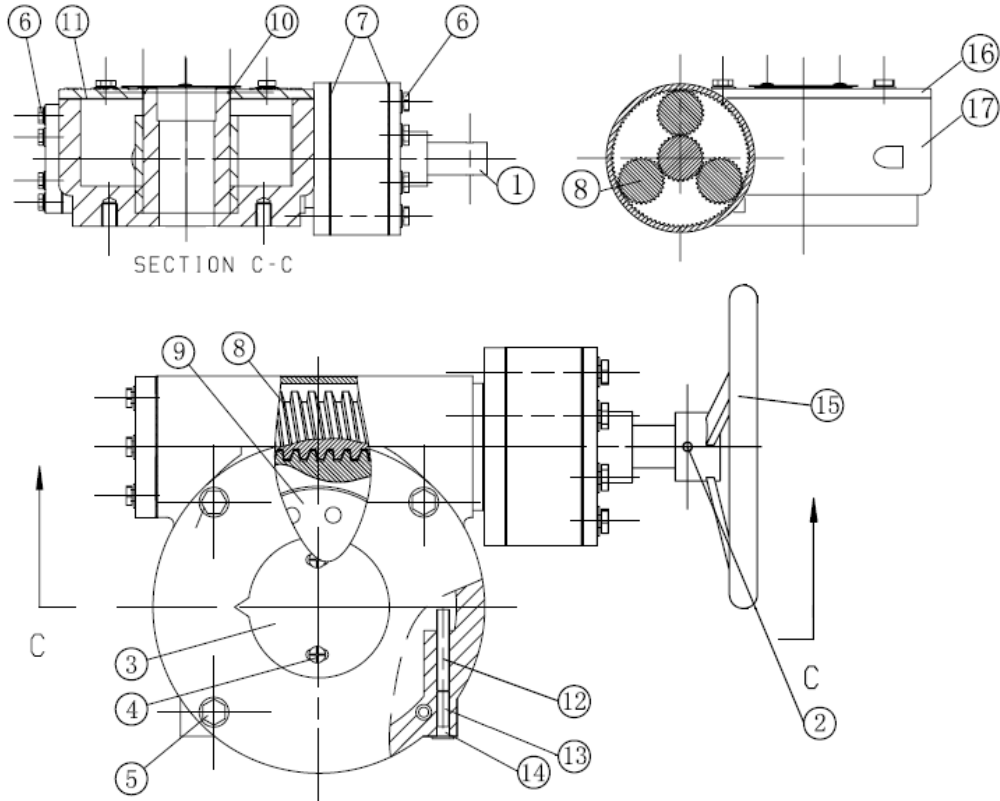

Item	Designation	Materials
1	Stem	Chromed steel
2	Pin	AISI 316
3	Indicator plate	Aluminium + NBR gasket
4	Indicator bolt, washer	AISI 316
5	Bolt, washer	AISI 316
6	Bolting	AISI 316
7	Body gasket	NBR
8	Gear 1	Steel
9	Gear 2	Ductile iron EN GJS-400-15
10	O ring	NBR
11	Bonnet gasket	NBR
12	Internal set screw	Carbon steel
13	External set screw	AISI 316
14	Plastic cap	Plastic
15	Handwheel	Cast iron EN GJL-250 epoxy coating
16	Bonnet	Cast iron EN GJL-250 epoxy coating
17	Body	Cast iron EN GJL-250 epoxy coating
	Bolting to fix on valve	AISI 304

CONCENTRIC LUG BUTTERFLY VALVE INITIAL RANGE CAST IRON BODY WITH STAINLESS STEEL DISC AND EPDM SEAT

VALVES WITH LEVER SIZE DN 40 – 300 (in mm) :

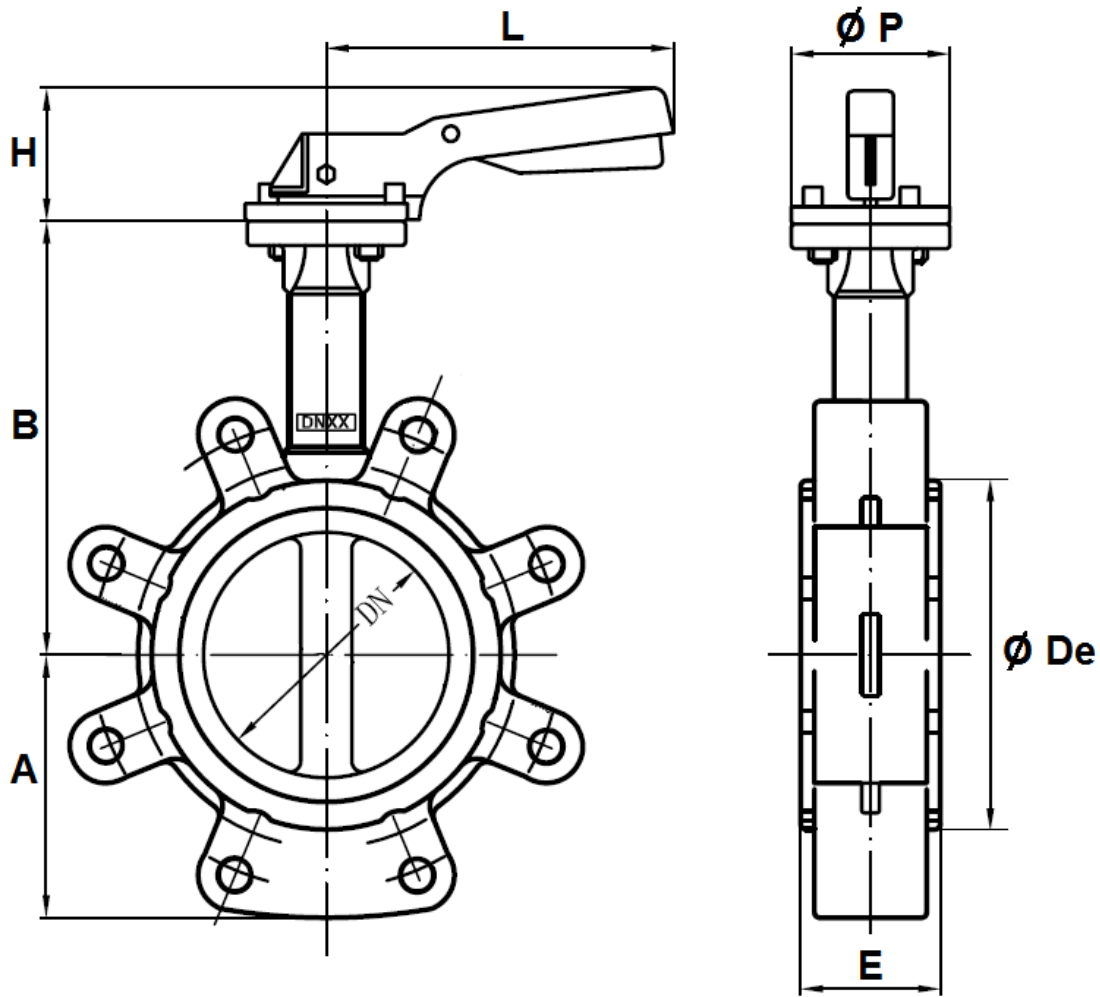

DN	40	50	65	80	100	125	150	200	250	300
A	61	77	88	95	107	122	144	171	205	235
B	130	137	142	158	180	192	215	242	280	310
Ø De	82	95	109	127	152	180	207	260	315	370
E	33	43	46	46	52	56	56	60	68	78
H	70	70	70	70	70	71	71	40	44	44
L	195	195	195	195	195	278	278	355	507	507
Ø P	65	65	65	65	65	90	90	125	150	150
Weig. (Kg)	2.43	3.13	3.73	4.98	5.64	9.06	10.96	16.67	31.4	42
Ref.	1133040	1133050	1133065	1133080	1133100	1133125	1133150	1133200-201	1133250-251	1133300-301

CONCENTRIC LUG BUTTERFLY VALVE INITIAL RANGE CAST IRON BODY WITH STAINLESS STEEL DISC AND EPDM SEAT

VALVES WITH GEARBOX SIZE DN 40 - 300 (in mm) :

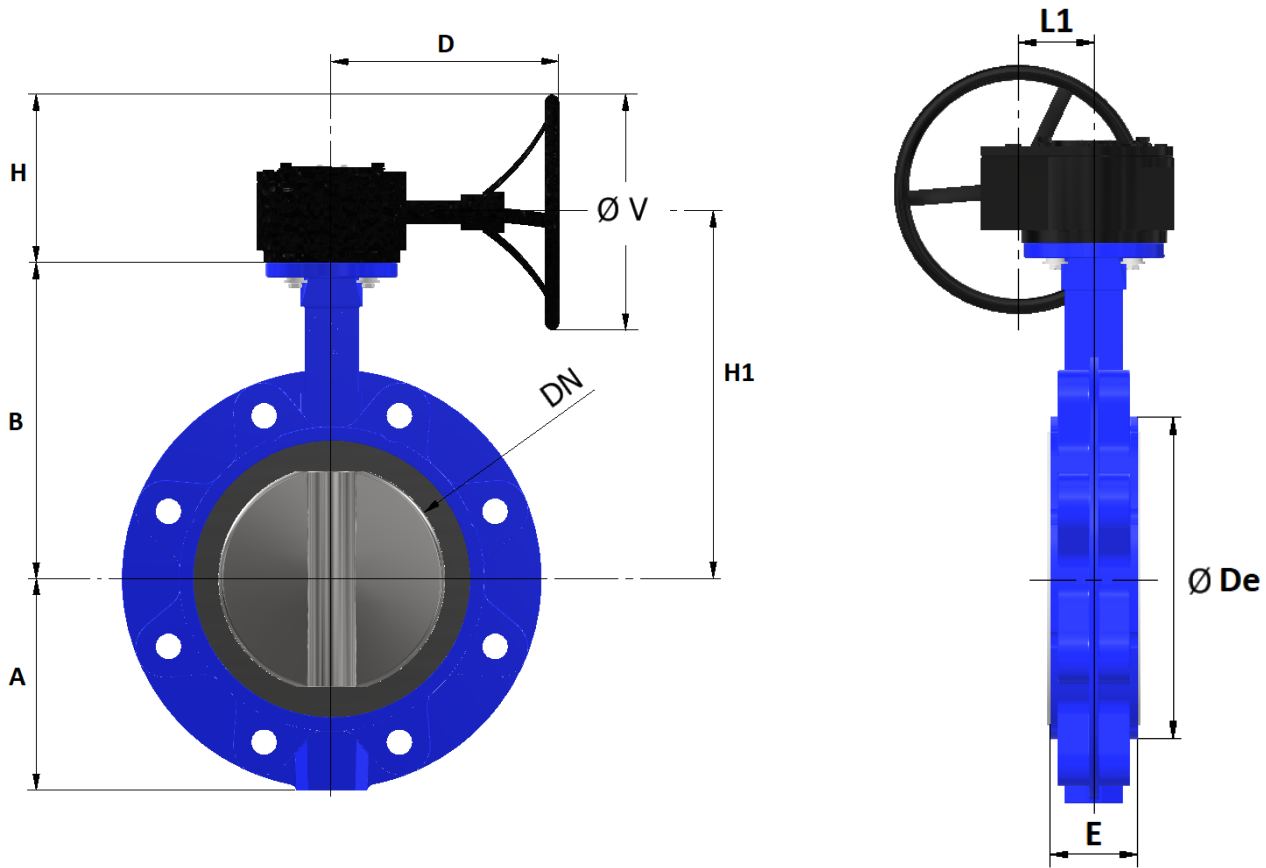

DN	40	50	65	80	100	125	150	200	250	300
A	61	77	88	95	107	122	144	171	205	235
B	130	137	142	158	180	192	215	242	280	310
D	162						224		223	
Ø De	82	95	109	127	152	180	207	260	315	370
E	33	43	46	46	52	56	56	60	68	78
H	112					162		191		192
H1	167	174	179	195	217	229	252	283	321	352
L1	44						66		77	
Ø V	150					250		300		
Weig. (Kg)	5.68	6.28	6.76	8.49	9.86	12.59	14.49	23.66	36.42	51.6
Ref.					1133102	1133127	1133152	1133202-203	1133252-253	1133302-303

CONCENTRIC LUG BUTTERFLY VALVE INITIAL RANGE CAST IRON BODY WITH STAINLESS STEEL DISC AND EPDM SEAT

VALVES WITH GEARBOX SIZE DN 350 (in mm) :

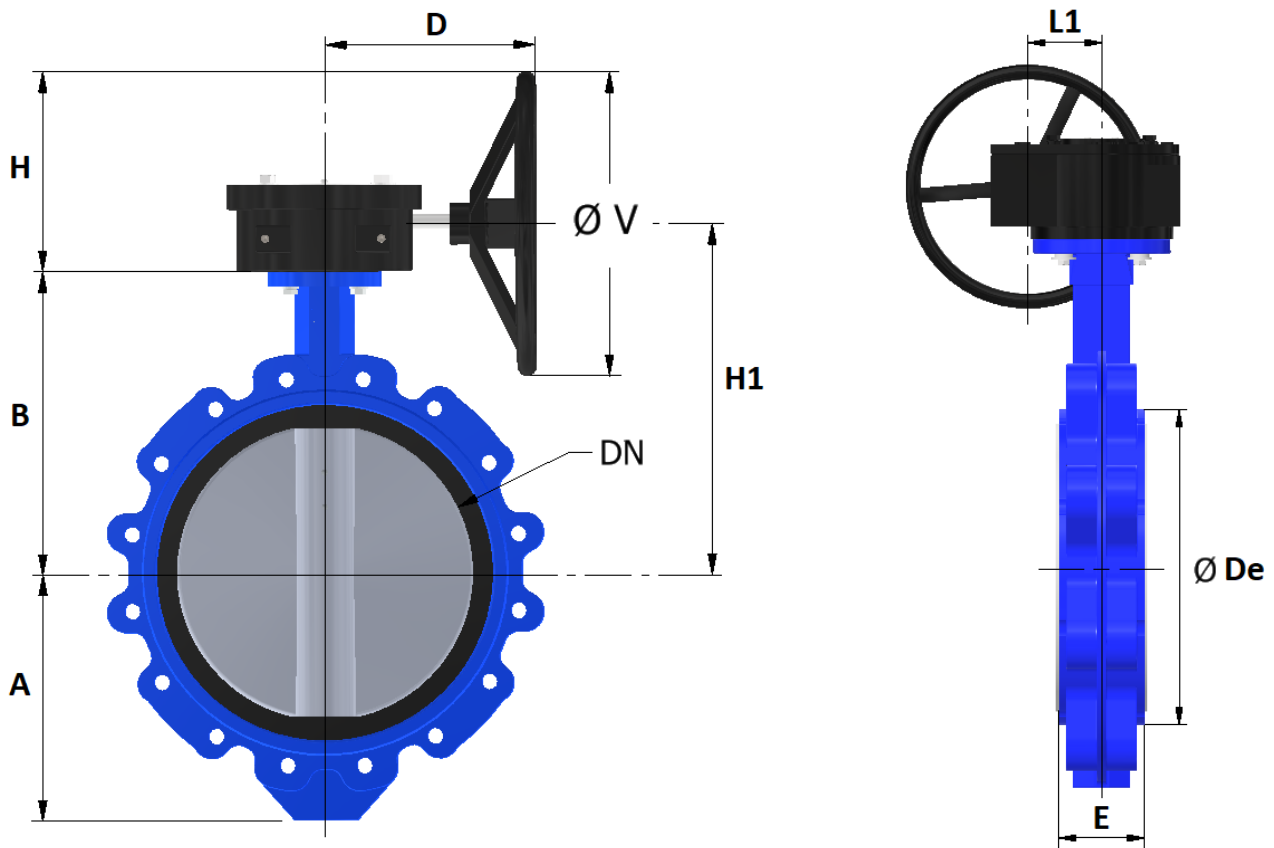

DN	350
A	266
B	367
D	223
Ø De	418
E	78
H	190
H1	412
L1	78
Ø V	300
Weight (Kg)	75.9
Ref.	1133350

CONCENTRIC LUG BUTTERFLY VALVE INITIAL RANGE CAST IRON BODY WITH STAINLESS STEEL DISC AND EPDM SEAT

VALVES WITH GEARBOX SIZE DN 400-600 (in mm) :

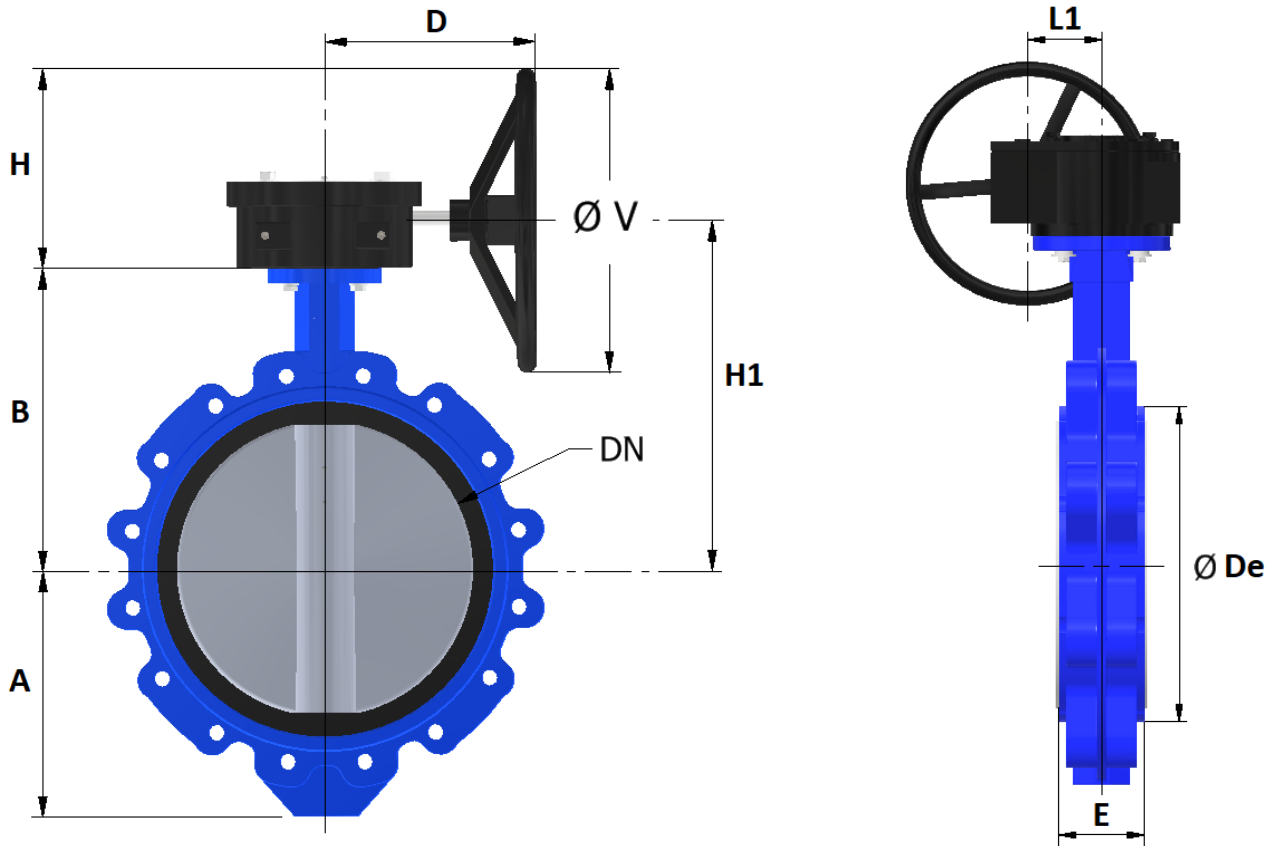

DN	400	450	500	600
A	324	341	374	478
B	394	419	474	565
D	270	270	339	339
Ø De	470	525	570	697
E	102	114	127	154
H	208	258	222	222
H1	456	481	539	630
L1	120	120	120	120
Ø V	400	400	300	300
Weight (Kg)	115.5	147	202.8	309.8
Ref.	1133400	1133450	1133500	1133600

CONCENTRIC LUG BUTTERFLY VALVE INITIAL RANGE CAST IRON BODY WITH STAINLESS STEEL DISC AND EPDM SEAT

SIZE GEARBOX DN40-350 (in mm) :

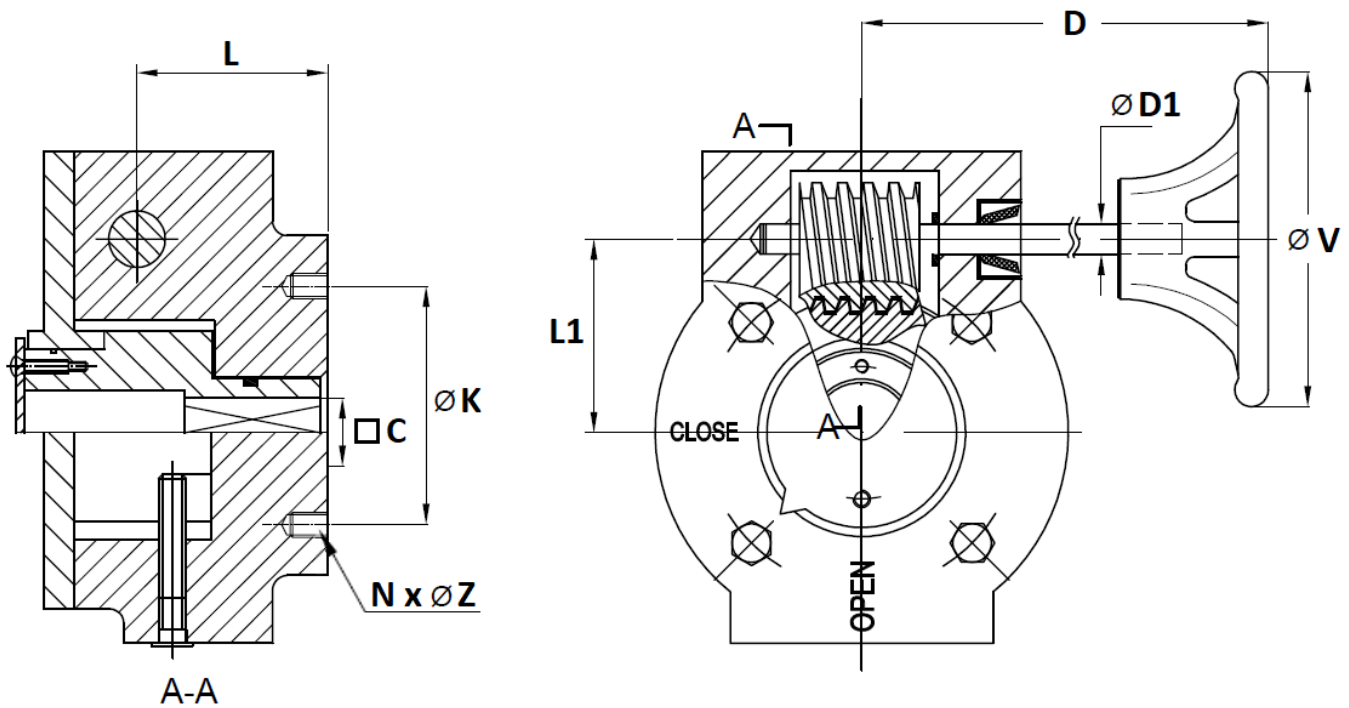

DN	32/80	100	125/150	200	250	300-350
C	9	11	14	17	22	27
Ø K	50	50	70	102	125	125
ISO	F05	F05	F07	F10	F12	F12
N x ØZ	4 x M6	4 x M6	4 x M8	4 x M10	4 x M12	4 x M12
L	37			41		42
D	162			224		223
L1	44			66		77
Ø D1	16			19		
Ø V	150		250	300		
Weight (kg)	3.51	4.22	3.53	6.99	7.42	9.6
Ref.	1198001	1198002	1198003	1198004	1198005	1198006

CONCENTRIC LUG BUTTERFLY VALVE INITIAL RANGE CAST IRON BODY WITH STAINLESS STEEL DISC AND EPDM SEAT

DISC AND NECK SIZE (in mm) :

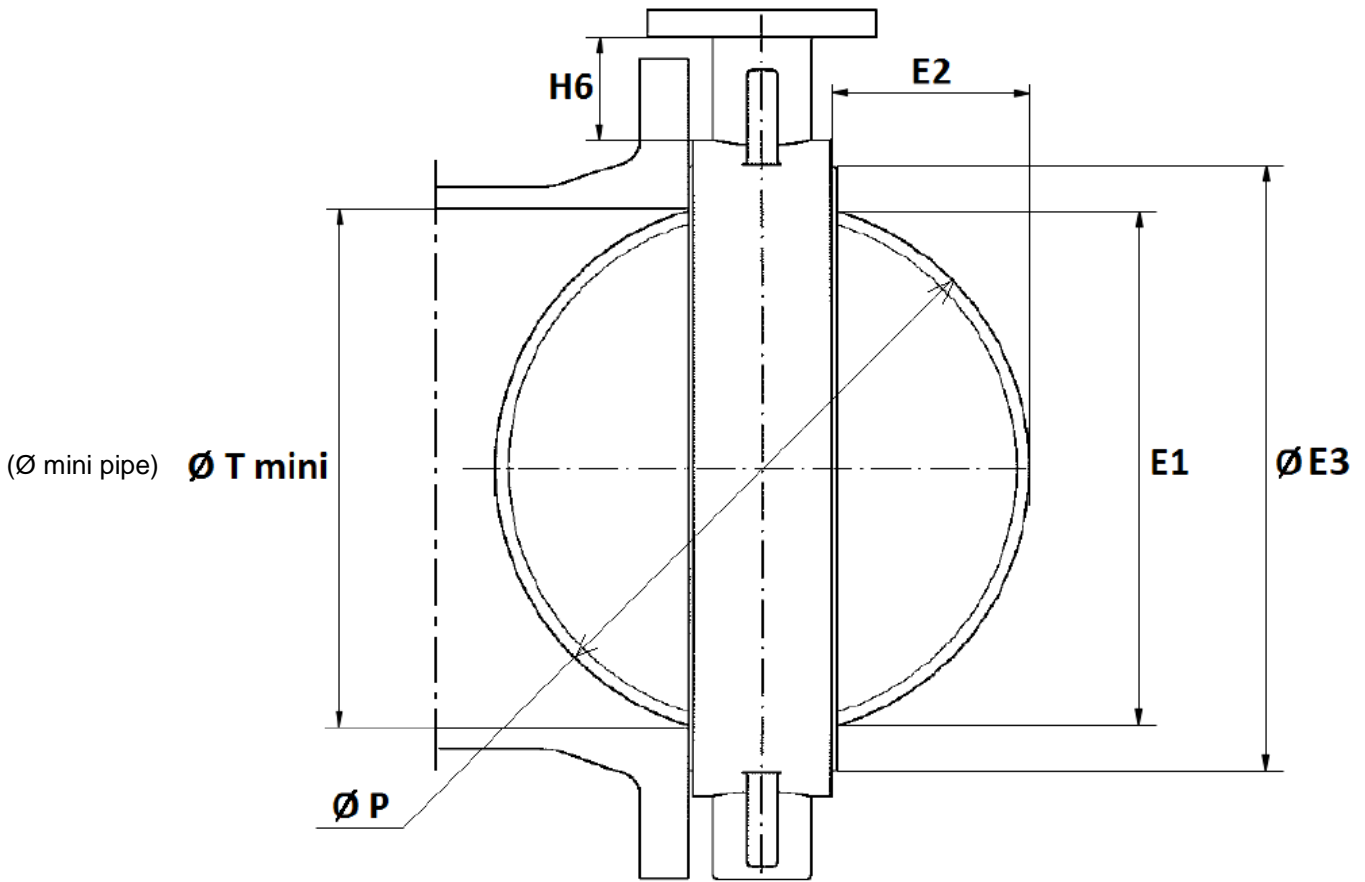

DN	40	50	65	80	100	125	150	200	250	300	350	400	450	500	600
E1	37.7	47.06	59.81	75.56	98.37	117.02	147.65	195.3	242.5	292.6	325.4	379.8	429	480.2	580.5
E2	4.9	5	9.4	16.5	26.1	33.9	49.7	71.2	91.2	111.8	127.8	143.9	163.3	182.3	219.3
Ø E3 ±2	70	76	90	104	135	159	188	238	292	344	375	439	490	535	654
H6 ±2	76.7	79	79	87.5	92.3	90.3	99.2	99.5	103.8	105.8	105.8	109.5	113	172	192
Ø P	42.8	53	64.8	79.1	104.25	123.8	155.4	202.4	250.5	301.6	333.7	389.8	440.7	491.8	592.7
Ø T mini	43	53	65	79.5	104.5	124	155.5	202.5	250.5	302	334	390	441	492	593

CONCENTRIC LUG BUTTERFLY VALVE INITIAL RANGE CAST IRON BODY WITH STAINLESS STEEL DISC AND EPDM SEAT

ISO 5211 MOUNTING PAD (in mm) :

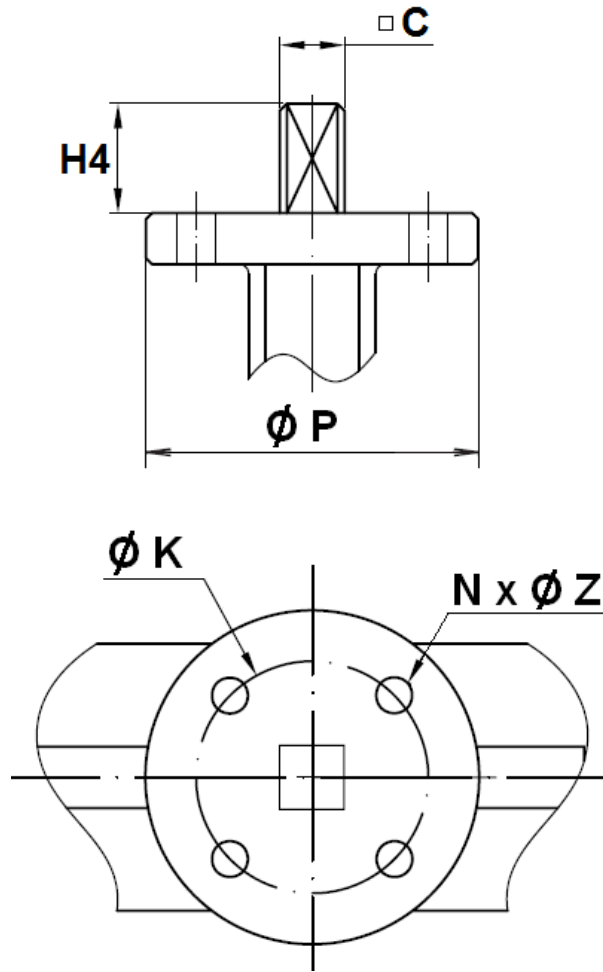

DN	40	50	65	80	100	125	150	200	250	300	350	400	450	500	600
C	9	9	9	9	11	14	14	17	22	27	27	27	30	36	46
Ø K	50	50	50	50	50	70	70	102	125	125	125	125	165	165	165
ISO	F05	F05	F05	F05	F05	F07	F07	F10	F12	F12	F12	F12	F16	F16	F16
Nx ØZ	4 x 7	4 x 7	4 x 7	4 x 7	4 x 7	4 x 9	4 x 9	4 x 11	4 x 13	4 x 13	4 x 14	4 x 14	4 x 22	4 x 22	4 x 22
H4	32	32	32	32	32	42	42	36	38	38	45	50	50	65	70
Ø P	65	65	65	65	65	90	90	125	150	150	150	150	210	210	300

CONCENTRIC LUG BUTTERFLY VALVE INITIAL RANGE CAST IRON BODY WITH STAINLESS STEEL DISC AND EPDM SEAT

FLANGES LUG SIZE PN10/16 (in mm) :

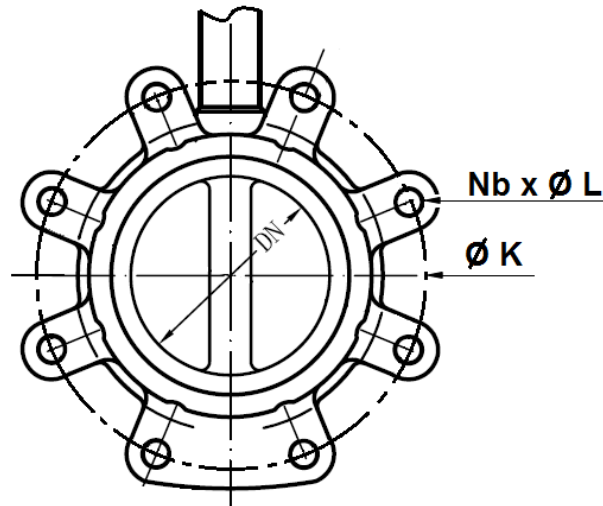

DN	40	50	65	80	100	125	150
Ø K	110	125	145	160	180	210	240
Nb x ØL	4 x M16	4 x M16	4 x M16	8 x M16	8 x M16	8 x M16	8 x M20
Ref.	1133040	1133050	1133065	1133080	1133100 and 1133102	1133125 and 1133127	1133150 and 1133152

FLANGES LUG SIZE PN10 (in mm) :

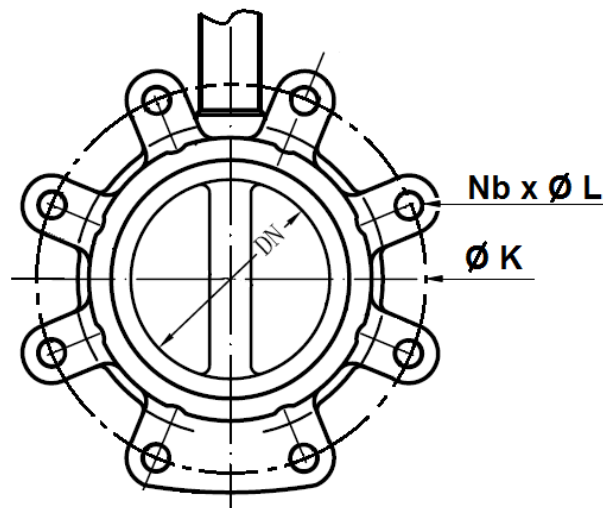

DN	200	250	300	350	400	450	500	600
Ø K	295	350	400	460	515	565	620	725
Nb x ØL	8 x M20	12 x M20	12 x M20	16 x M20	16 x M24	20 x M24	20 x M24	20 x M27
Ref.	1133200 and 1133202	1133250 and 1133252	1133300 and 1133302	1133350	1133400	1133450	1133500	1133600

CONCENTRIC LUG BUTTERFLY VALVE INITIAL RANGE CAST IRON BODY WITH STAINLESS STEEL DISC AND EPDM SEAT

FLANGES LUG SIZE PN16 (in mm) :

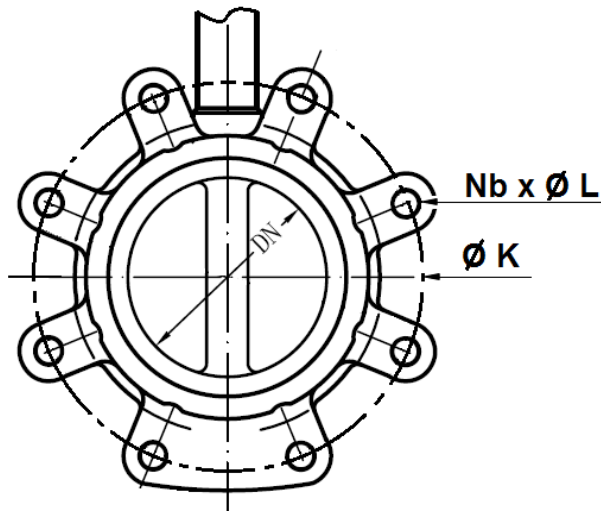

DN	200	250	300	350	400	450	500	600
Ø K	295	355	410	470	525	585	650	770
Nb x ØL	12 x M20	12 x M24	12 x M24	16 x M24	16 x M27	20 x M27	20 x M30	20 x M33
Ref.	1133201 and 1133203	1133251 and 1133253	1133301 and 1133303	1133351	1133401	1133451	1133501	1133601

CONCENTRIC LUG BUTTERFLY VALVE INITIAL RANGE CAST IRON BODY WITH STAINLESS STEEL DISC AND EPDM SEAT

GEARBOX SPECIFICATIONS :

DN	32/80	100	125/150	200	250	300-350
Ref.	1198001	1198002	1198003	1198004	1198005	1198006
Ratio factor	24 :1	24 :1	24 :1	30 :1	30 :1	50 :1
Input torque (Nm)	18	18	18	58	58	60
Output torque (Nm)	170	170	170	700	700	1200

DN	400	450	500	600
Ratio factor	80 :1	80 :1	260 :1	300 :1
Input torque (Nm)	78	78	30	45
Output torque (Nm)	2500	2500	2500	4000

CONCENTRIC LUG BUTTERFLY VALVE INITIAL RANGE CAST IRON BODY WITH STAINLESS
STEEL DISC AND EPDM SEAT

STANDARDS :

- Manufacturer certified ISO 9001 : 2015
- Designing according to API 609
- DIRECTIVE 2014/68/EU: For liquids and gas of Group 1
 - DN32-50: Risk Category I, CE marking
 - DN65-200: Risk Category II, CE 0035 marking
 - DN250-300: Risk Category III, CE 0035 marking
 - DN350: Risk Category II, CE 0035 marking
 - DN400-600: Risk Category III, CE 0035 marking
- Certificate 3.1 on request
- Pressure tests according to API 598, table 6
- Length according to ISO 5752 series 20, EN 558 series 20 (NF 29305)
- ISO 5211 mounting pad
- Between flanges according to EN 1092-1 PN10/16
- Valves according to LR Rules and Regulation for the classification of Ships, July 2018 (Type Approval Certificate) **Marine LLOYD'S REGISTER**. Marine and offshore subject to the valves complying LR Rules and Regulations for the particular services.
 - API 607 - 2016
 - ISO 19921:2005
 - GB/T 22218 - 2008

ADVICE : Our opinion and our advice are not guaranteed and SFERACO shall not be liable for the consequences of damages. The customer must check the right choice of the products with the real service conditions.