

CONCENTRIC LUG BUTTERFLY VALVE INITIAL RANGE CAST IRON BODY WITH STAINLESS STEEL DISC AND NBR SEAT

Lug butterfly valve initial range for non aromatic hydrocarbon, fuel, water, natural gas, grease, oil, compressed air, glycol.
 Cast iron EN GJL-250 body, stainless steel disc and NBR seat.
 Between flanges PN10/PN16.
 Handling possible with gearbox.
 Thanks to the ISO 5211 plate, an actuator can be installed on the valve.



Painting color is actually changing for RAL5005



New painting



Old painting

- Size :** DN40 to DN300
- Connection :** Between flanges PN10/16
- Min Temperature :** -10°C
- Max Temperature :** +80°C
- Max Pressure :** 16 Bars
- Specifications :** Long neck for isolation
 Stainless steel disc
 NBR vulcanized seat
 ISO 5211 mounting pad

Materials : Cast iron body EN GJL-250, NBR seat

CONCENTRIC LUG BUTTERFLY VALVE INITIAL RANGE CAST IRON BODY WITH STAINLESS STEEL DISC AND NBR SEAT

SPECIFICATIONS :

- Long neck for isolation
- ISO 5211 mounting pad
- Lug type
- Between flanges PN10 or PN16 from DN 40 to DN 300
- Full crossing stem
- 10 positions cranted lever, with locking device up to DN150
- Double PTFE gasket on stem
- Stainless steel disc
- Epoxy painting RAL003 80 microns thickness, **painting color is actually changing for RAL5005**
- NBR vulcanized seat

USE :

- No aromatic hydrocarbon, fuel, water, natural gas, grease, oil, compressed air, glycol
- Min and max Temperature Ts : - 10°C to + 80°C
- Max Pressure Ps : 16 bars
- Can be used at the end of the pipe (10 bars maxi) with a counter flange installed at the end of the valve

FLOW COEFFICIENT Kv (M3 / h) :

DN		32/40	50	65	80	100	125	150	200	250	300
Opening angle	10°	0,04	0,05	0,09	0,17	0,26	0,43	0,68	1,7	2,6	3,4
	20°	2	3	5	8	15	25	38	76	129	200
	30°	5	6	10	15	31	52	81	160	273	422
	40°	10	13	21	33	67	113	175	348	592	914
	50°	18	23	38	60	119	202	312	620	1055	1630
	60°	30	38	64	99	196	334	516	1025	1746	2697
	70°	48	60	102	156	310	529	817	1623	2764	4269
	80°	72	90	152	235	466	793	1226	2434	4145	6403
	90°	78	98	167	258	512	872	1347	2675	4555	7037

TORQUE VALUES (Nm, without safety coefficient) :

We recommend a safety coefficient of 30% minimum to determinate the actuator.

DN	32/40	50	65	80	100	125	150	200	250	300
PN10	9	12	19	25	38	58	85	159	253	369
PN16	10	13	21	26	42	65	95	175	277	536

**CONCENTRIC LUG BUTTERFLY VALVE INITIAL RANGE CAST IRON BODY WITH STAINLESS
STEEL DISC AND NBR SEAT**

PRESSURE / TEMPERATURE GRAPH (STEAM EXCLUDED) :

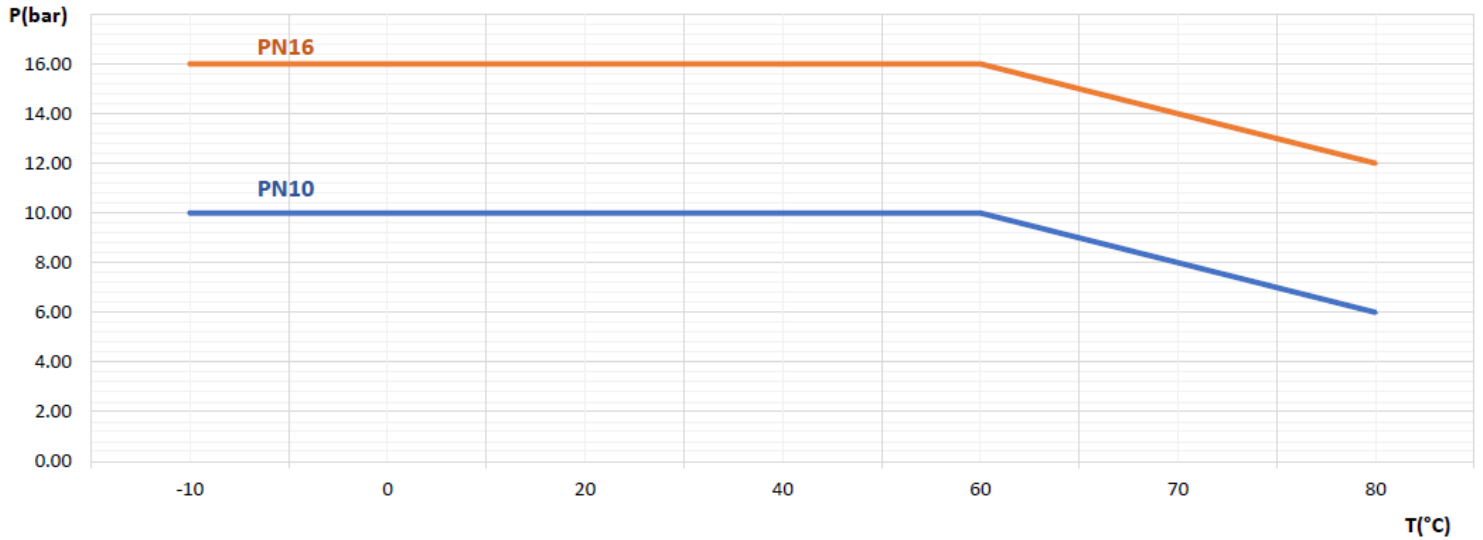

RANGE :

- With lever from DN40 to DN300
- Gearbox possible from DN40 to DN300 **Ref.1198**

CONCENTRIC LUG BUTTERFLY VALVE INITIAL RANGE CAST IRON BODY WITH STAINLESS STEEL DISC AND NBR SEAT

MATERIALS :

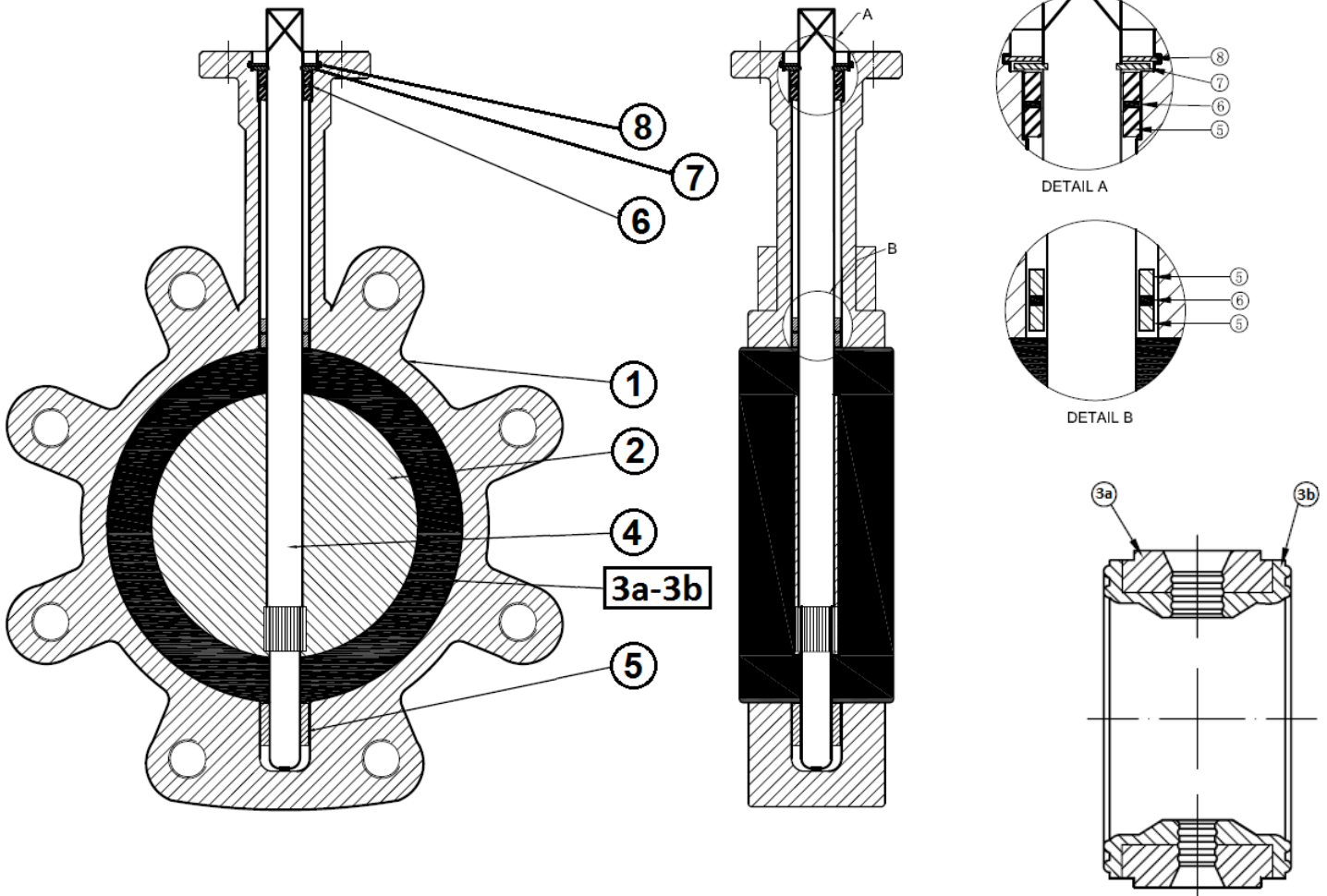

Item	Designation	Materials
1	Body	Cast iron EN GJL-250
2	Disc	ASTM A351 CF8M
3a	Insert	Fibers
3b	Seat	Vulcanized NBR
4	Stem	AISI 420
5	Bushing	PTFE
6	O ring	NBR
7	Circlip	Steel
8	Circlip	Steel
	Lever	Aluminium

CONCENTRIC LUG BUTTERFLY VALVE INITIAL RANGE CAST IRON BODY WITH STAINLESS STEEL DISC AND NBR SEAT

MATERIALS GEARBOX :

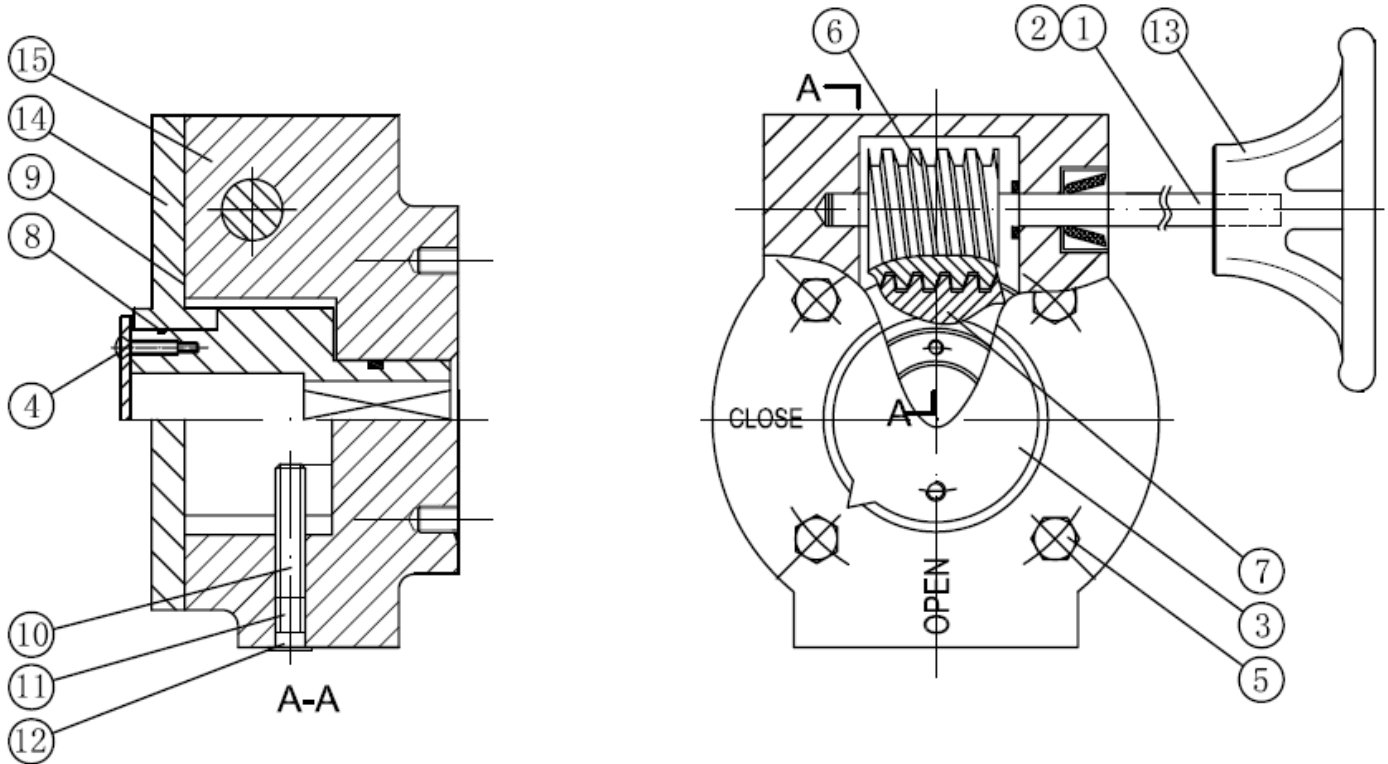

Item	Designation	Materials
1	Stem	Chromed steel
2	Pin	AISI 316
3	Indicator plate	Aluminium + NBR gasket
4	Indicator bolt, washer	AISI 316
5	Bolt, washer	AISI 316
6	Gear 1	Steel
7	Gear 2	Ductile iron EN GJS-400-15
8	O ring	NBR
9	Bonnet gasket	NBR
10	Internal set screw	Carbon steel
11	External set screw	AISI 316
12	Plastic cap	Plastic
13	Handwheel	Cast iron EN GJL-250 epoxy coating
14	Bonnet	Cast iron EN GJL-250 epoxy coating
15	Body	Cast iron EN GJL-250 epoxy coating
	Bolting to fix on valve	AISI 304

**CONCENTRIC LUG BUTTERFLY VALVE INITIAL RANGE CAST IRON BODY WITH STAINLESS
STEEL DISC AND NBR SEAT**

VALVES WITH LEVER SIZE DN 40 – 300 (in mm) :

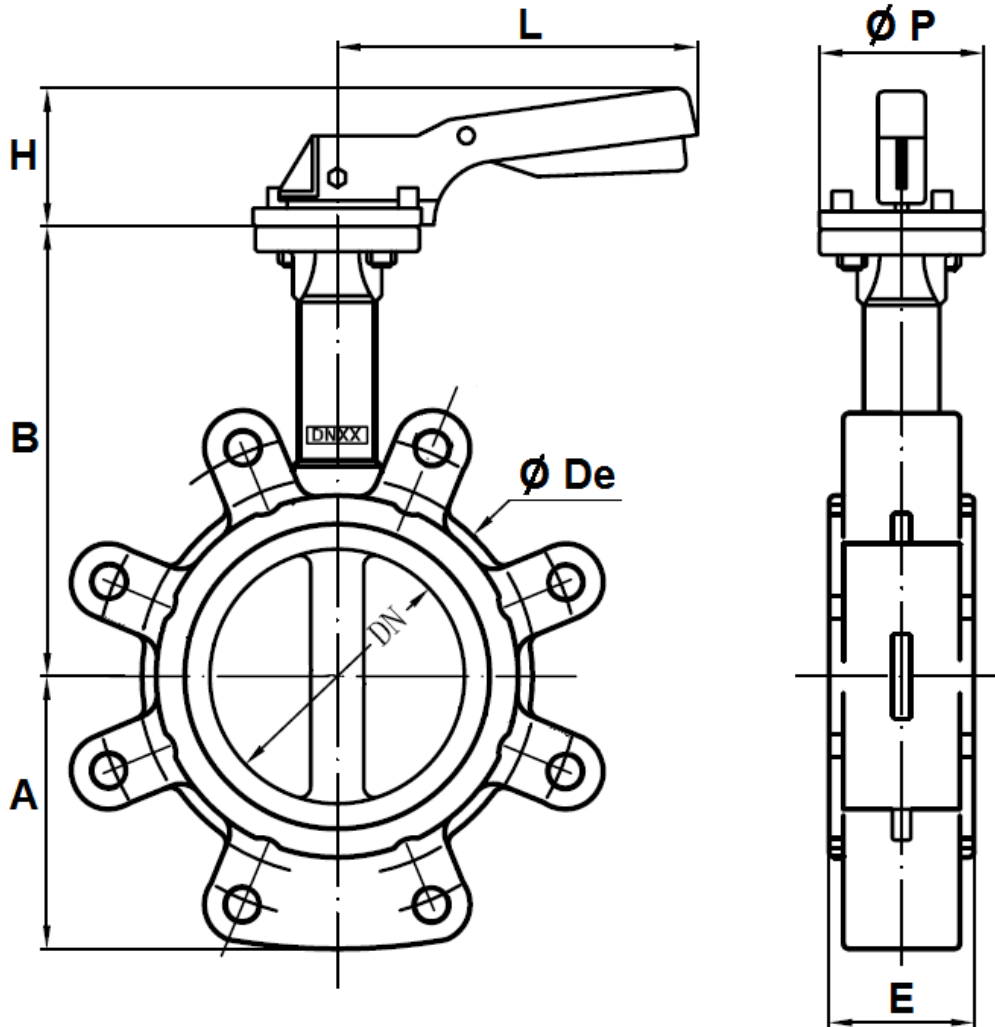

DN	40	50	65	80	100	125	150	200	250	300
A	61	77	88	95	107	122	144	171	205	235
B	130	137	142	158	180	192	215	242	280	310
Ø De	82	95	109	127	152	180	207	260	315	370
E	33	43	46	46	52	56	56	60	68	78
H	70	70	70	70	70	71	71	40	44	44
L	195	195	195	195	195	278	278	355	507	507
Ø P	65	65	65	65	65	90	90	125	150	150
Weig. (Kg)	2.17	2.77	3.25	4.98	5.64	9.06	10.96	16.67	29	42
Ref.	1131040	1131050	1131065	1131080	1131100	1131125	1131150	1131200-201	1131250-251	1131300-301

CONCENTRIC LUG BUTTERFLY VALVE INITIAL RANGE CAST IRON BODY WITH STAINLESS STEEL DISC AND NBR SEAT

VALVES WITH GEARBOX SIZE DN 40 - 300 (in mm) :

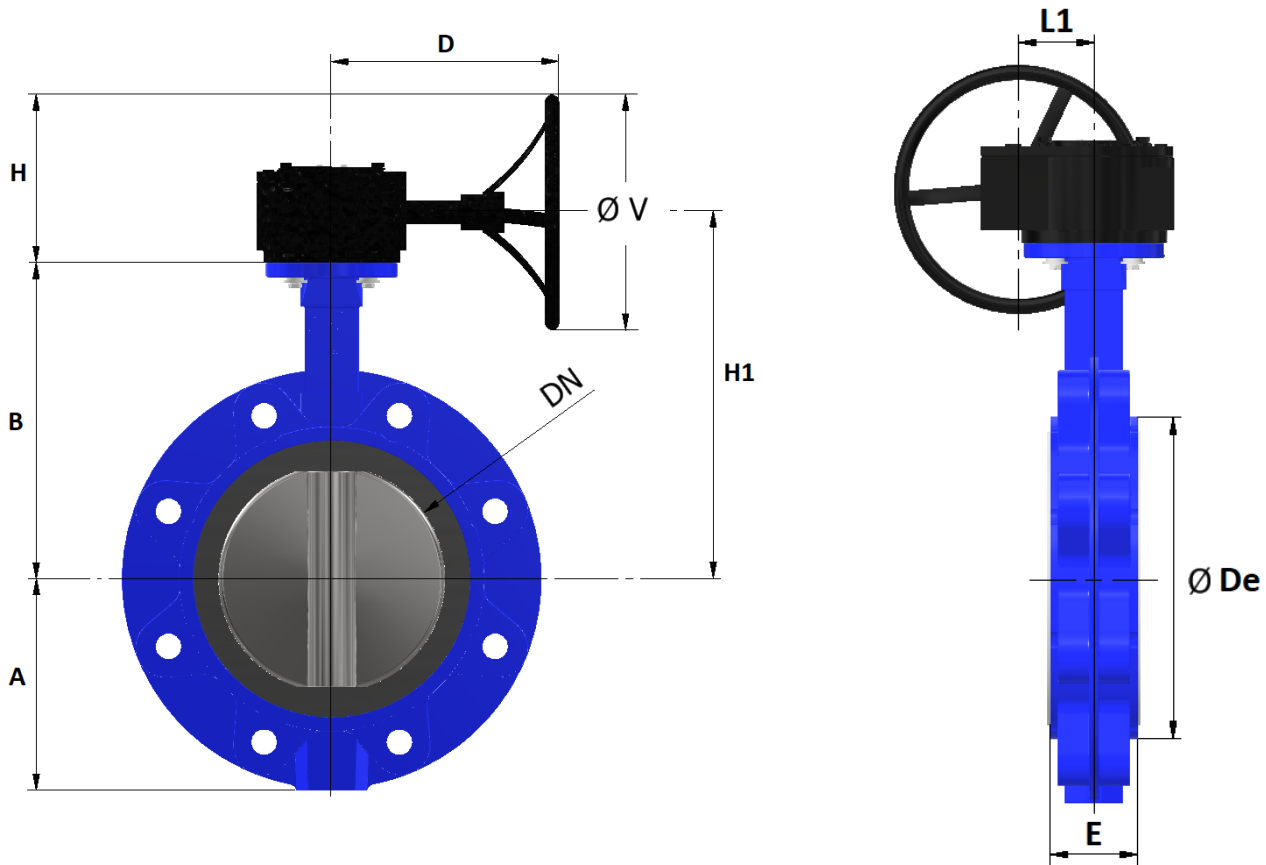

DN	40	50	65	80	100	125	150	200	250	300
A	61	77	88	95	107	122	144	171	205	235
B	130	137	142	158	180	192	215	242	280	310
D	162						224		223	
Ø De	82	95	109	127	152	180	207	260	315	370
E	33	43	46	46	52	56	56	60	68	78
H	112					162		191		192
H1	167	174	179	195	217	229	252	283	321	352
L1	44						66		77	
Ø V	150					250		300		
Weig. (Kg)	5.68	6.28	6.76	8.49	9.86	12.59	14.49	23.66	36.42	51.6
Ref.					1131102	1131127	1131152	1131202-203	1131252-253	1131302-303

CONCENTRIC LUG BUTTERFLY VALVE INITIAL RANGE CAST IRON BODY WITH STAINLESS STEEL DISC AND NBR SEAT

SIZE GEARBOX DN40-300 (in mm) :

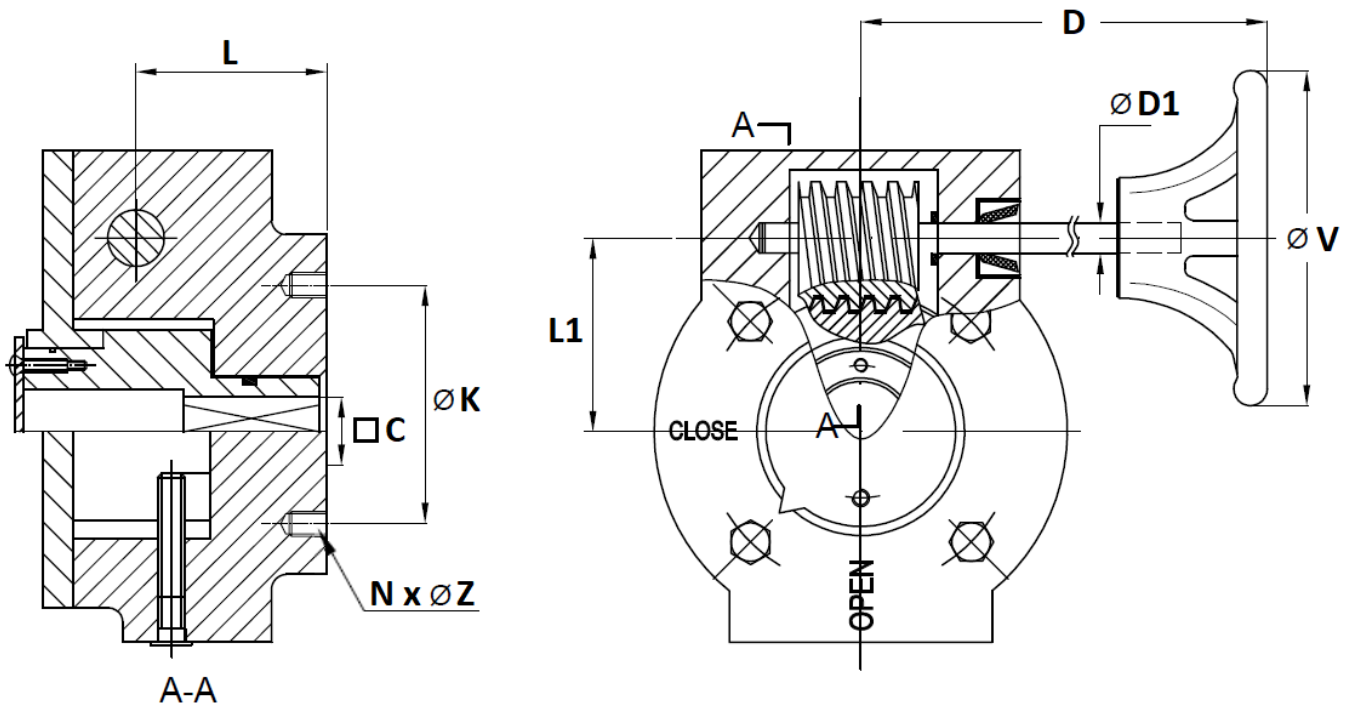

DN	32/80	100	125/150	200	250	300-350
C	9	11	14	17	22	27
Ø K	50	50	70	102	125	125
ISO	F05	F05	F07	F10	F12	F12
N x ØZ	4 x M6	4 x M6	4 x M8	4 x M10	4 x M12	4 x M12
L	37		41		42	
D	162		224		223	
L1	44		66		77	
Ø D1	16		19			
Ø V	150		250	300		
Weight (kg)	3.51	4.22	3.53	6.99	7.42	9.6
Ref.	1198001	1198002	1198003	1198004	1198005	1198006

CONCENTRIC LUG BUTTERFLY VALVE INITIAL RANGE CAST IRON BODY WITH STAINLESS STEEL DISC AND NBR SEAT

DISC AND NECK SIZE (in mm) :

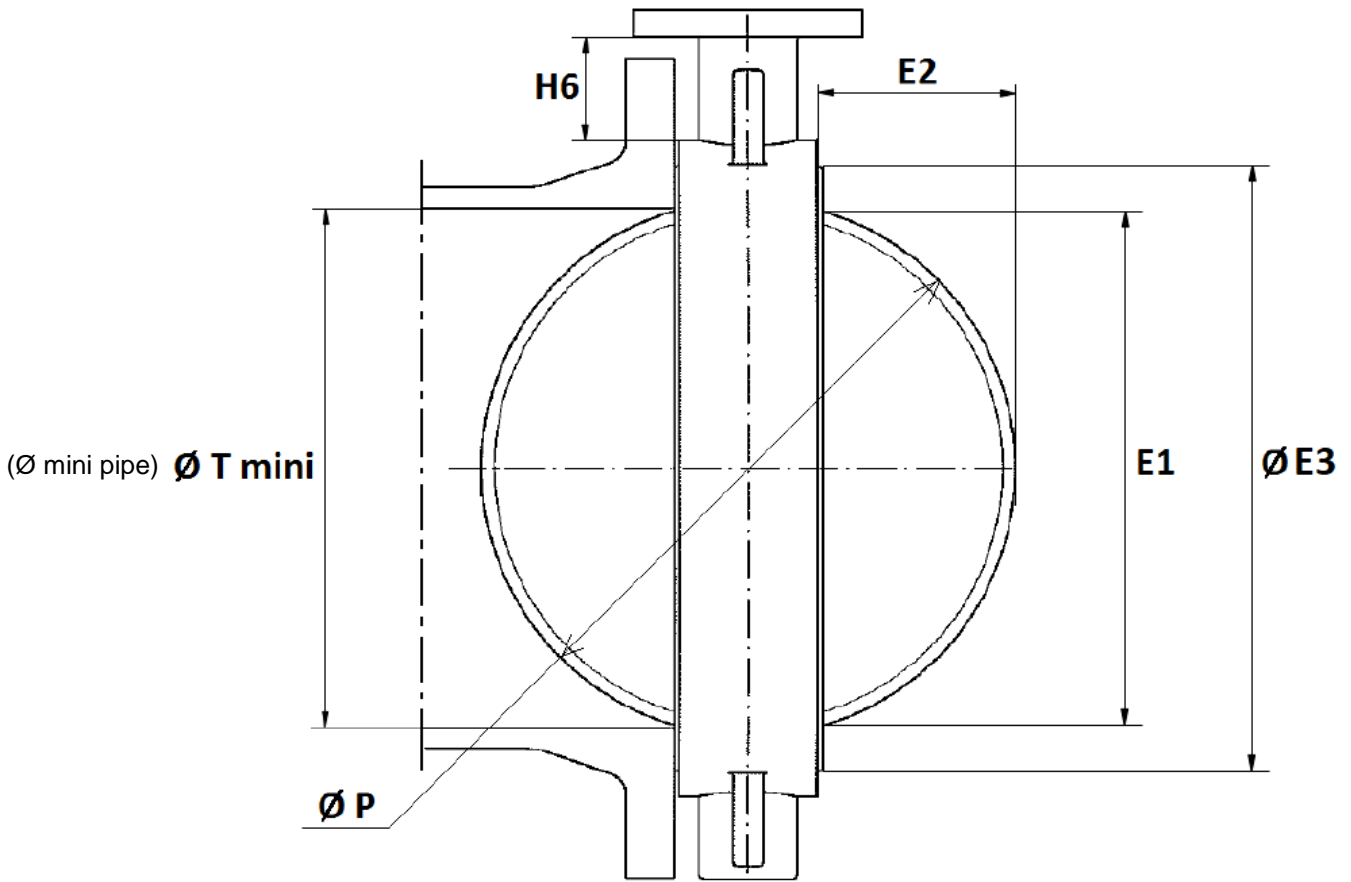

DN	40	50	65	80	100	125	150	200	250	300
E1	37.7	47.06	59.81	75.56	98.37	117.02	147.65	195.3	242.5	292.6
E2	4.9	5	9.4	16.5	26.1	33.9	49.7	71.2	91.2	111.8
Ø E3 ±2	70	76	90	104	135	159	188	238	292	344
H6 ±2	76.7	79	79	87.5	92.3	90.3	99.2	99.5	103.8	105.8
Ø P	42.8	53	64.8	79.1	104.25	123.8	155.4	202.4	250.5	301.6
Ø T mini	43	53	65	79.5	104.5	124	155.5	202.5	250.5	302

CONCENTRIC LUG BUTTERFLY VALVE INITIAL RANGE CAST IRON BODY WITH STAINLESS STEEL DISC AND NBR SEAT

ISO 5211 MOUNTING PAD (in mm) :

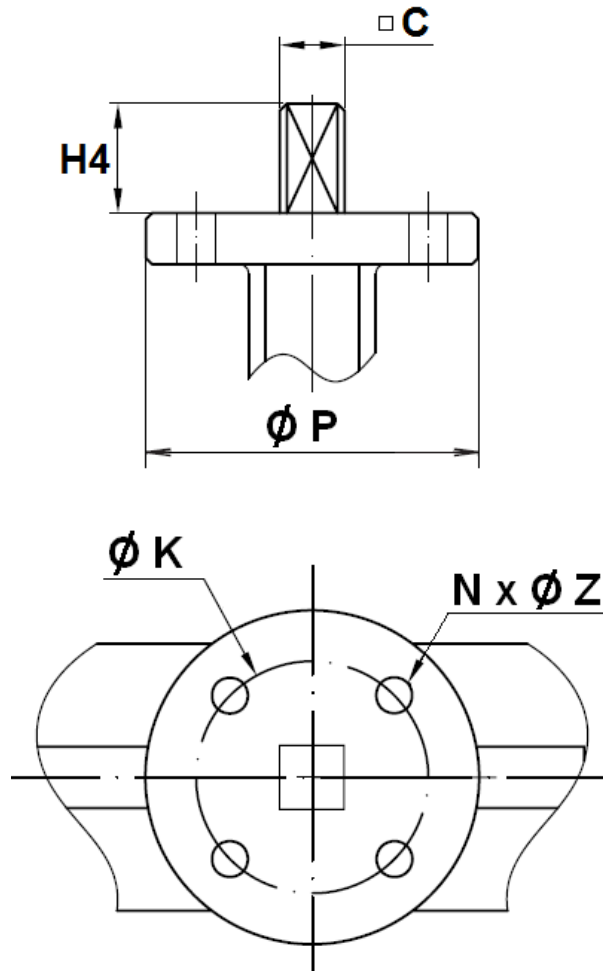

DN	40	50	65	80	100	125	150	200	250	300
C	9	9	9	9	11	14	14	17	22	27
$\varnothing K$	50	50	50	50	50	70	70	102	125	125
ISO	F05	F05	F05	F05	F05	F07	F07	F10	F12	F12
$N \times \varnothing Z$	4 x 7	4 x 7	4 x 7	4 x 7	4 x 7	4 x 9	4 x 9	4 x 11	4 x 13	4 x 13
H4	32	32	32	32	32	42	42	36	38	38
$\varnothing P$	65	65	65	65	65	90	90	125	150	150

CONCENTRIC LUG BUTTERFLY VALVE INITIAL RANGE CAST IRON BODY WITH STAINLESS STEEL DISC AND NBR SEAT

FLANGES LUG SIZE (in mm) :

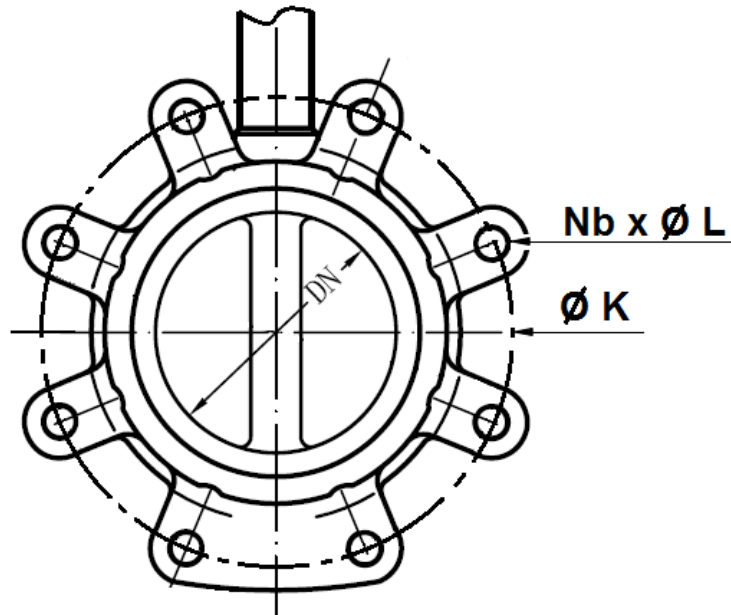

DN	40	50	65	80	100	125	150
PN	PN10/16						
Ø K	110	125	145	160	180	210	240
Nb x ØL	4 x M16	4 x M16	4 x M16	8 x M16	8 x M16	8 x M16	8 x M20
Ref.	1131040	1131050	1131065	1131080	1131100	1131125	1131150

DN	200	200	250	250	300	300
PN	PN10	PN16	PN10	PN16	PN10	PN16
Ø K	295	295	350	355	400	410
Nb x ØL	8 x M20	12 X M20	12 x M20	12 x M24	12 x M20	12 x M24
Ref.	1131200	1131201	1131250	1131251	1131300	1131301

CONCENTRIC LUG BUTTERFLY VALVE INITIAL RANGE CAST IRON BODY WITH STAINLESS STEEL DISC AND NBR SEAT

GEARBOX SPECIFICATIONS :

DN	32/80	100	125/150	200	250	300
Ref.	1198001	1198002	1198003	1198004	1198005	1198006
Ratio factor	24 :1	24 :1	24 :1	30 :1	30 :1	50 :1
Input torque (Nm)	18	18	18	58	58	60
Output torque (Nm)	170	170	170	700	700	1200

STANDARDS :

- Manufacturer certified ISO 9001 : 2015
- Designing according to API 609
- DIRECTIVE 2014/68/EU: For liquids and gas of Group 1
 - DN32-50: Risk Category I, CE marking
 - DN65-200: Risk Category II, CE 0035 marking
 - DN250-300: Risk Category III, CE 0035 marking
- Certificate 3.1 on request
- Pressure tests according to API 598, table 6
- Length according to ISO 5752 series 20, EN 558 series 20 (NF 29305)
- ISO 5211 mounting pad
- Between flanges according to EN 1092-1 PN10/16
- Valves according to LR Rules and Regulation for the classification of Ships, July 2018 (Type Approval Certificate) **Marine LLOYD'S REGISTER**. Marine and offshore subject to the valves complying LR Rules and Regulations for the particular services.
 - API 607 - 2016
 - ISO 19921:2005
 - GB/T 22218 - 2008

ADVICE : Our opinion and our advice are not guaranteed and SFERACO shall not be liable for the consequences of damages. The customer must check the right choice of the products with the real service conditions.