

# 1121-1125 BUTTERFLY VALVES WITH AP RE PNEUMATIC ACTUATOR

## FEATURES

1121 to 1125 butterfly valves are intended for the automatic opening /closing of different usual fluid pipes. The valve body is made of grey cast iron. The different configurations of the butterfly materials and of the liner make it suitable for different applications. Wafer mounting with centring ears between PN10/16 or ANSI 150 flanges. The long neck makes the mounting on heat-insulated pipe installations possible. The ISO 5211 mounting pad allows the actuator to be directly assembled. The AP RE (adjustable stops) pneumatic motorisation is available in double and spring-return with numerous options.

## LIMITS OF USE

<b>Fluid pressure: PS</b>	16 bar up to DN 300
<b>Fluid temperature: WT</b>	According to the table below
<b>Prohibited uses</b>	Steam, natural gas
<b>Ambient temperature</b>	-10°C / +80°C
<b>Motor compressed air</b>	mini 6 bar / maxi 10 bar

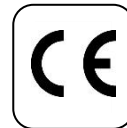

## AVAILABLE MODELS

DN 40 to DN 300.

Connection between flanges PN10/16 and ANSI 150 RF

Double and spring-return actuator.

Ref.	Butterfly	Liner	Example of applications	WT° min	WT° max
1121	stainless steel	NBR	Liquid hydrocarbons - compressed air	-10°C	+90°C
1123	Stainless steel	EPDM	Demineralised water - alkalis	-10°C	+110°C
1125	cast iron	EPDM	Hot water - cold water	-10°C	+110°C

## DIRECTIVES AND MANUFACTURING STANDARDS

OBJECT	Standard	ON	OBJECT	Standard
Pressure Equipment Directive 2014/68/EC	Cat. III module H	0035	Final test	API 598
Face-to-face dimension	ISO 5752 series 20		Actuator pilot connection	NAMUR
Flange dimension	EN 1092-1		Switch box connection	VDI/VDE 3845
Connection Motorisation	ISO 5211		SIL 3 level (the actuator alone)	EN 61508

Information given as an indication only, and subject to possible modifications



# 1121-1125 BUTTERFLY VALVES WITH AP RE PNEUMATIC ACTUATOR

## CONSTRUCTION

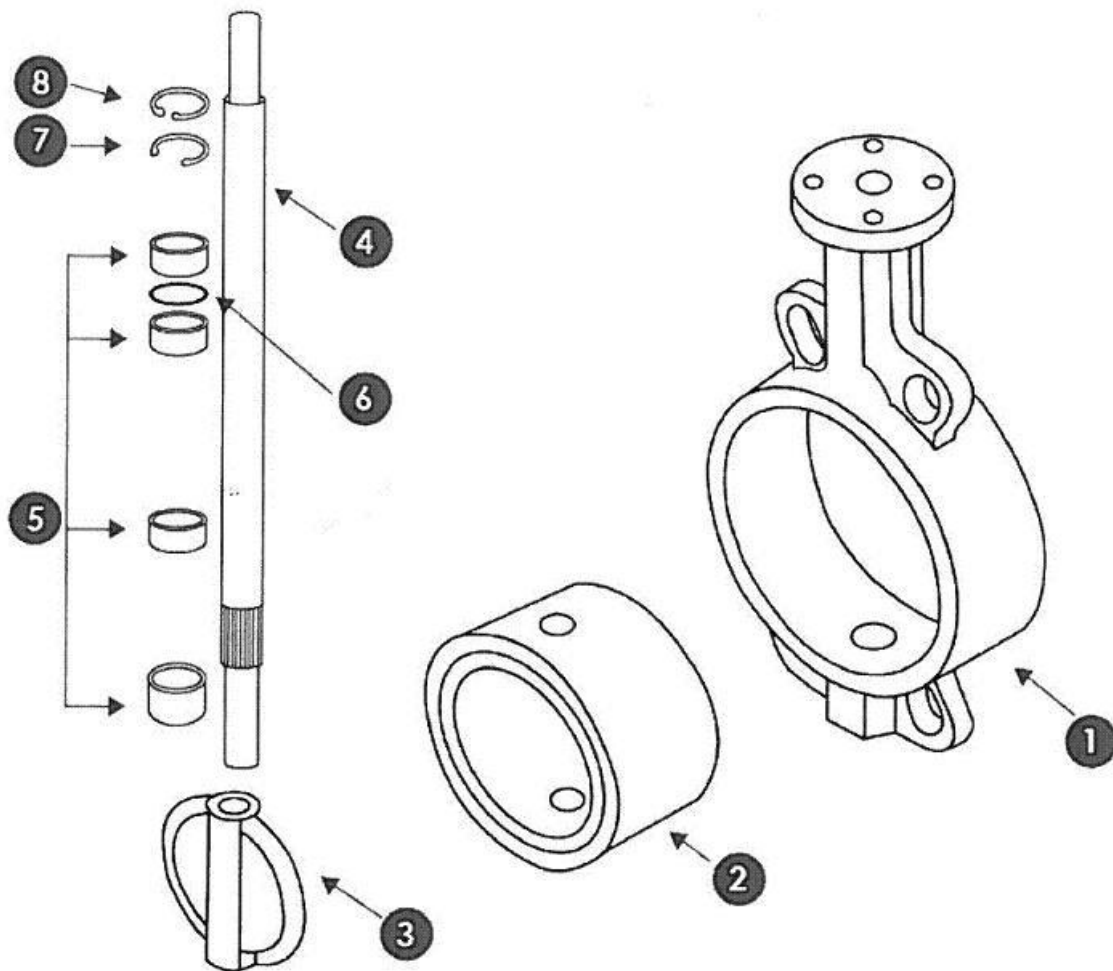

No.	Name	1121	1123	1125
1	Body	EN GJL-250 grey cast iron		
2	Liner	NBR	EPDM	EPDM
3	Butterfly	1.4408 SS	1.4408 SS	EN GJS-400-15 nickel-plated cast iron
4	Crossing stem	416 SS		
5	Bearings	PTFE		
6	O-ring	NBR	NBR	NBR
7	Circlips	Steel		
8	Circlips	Steel		

Information given as an indication only, and subject to possible modifications



# 1121-1125 BUTTERFLY VALVES WITH AP RE PNEUMATIC ACTUATOR

## DIMENSIONS (mm)

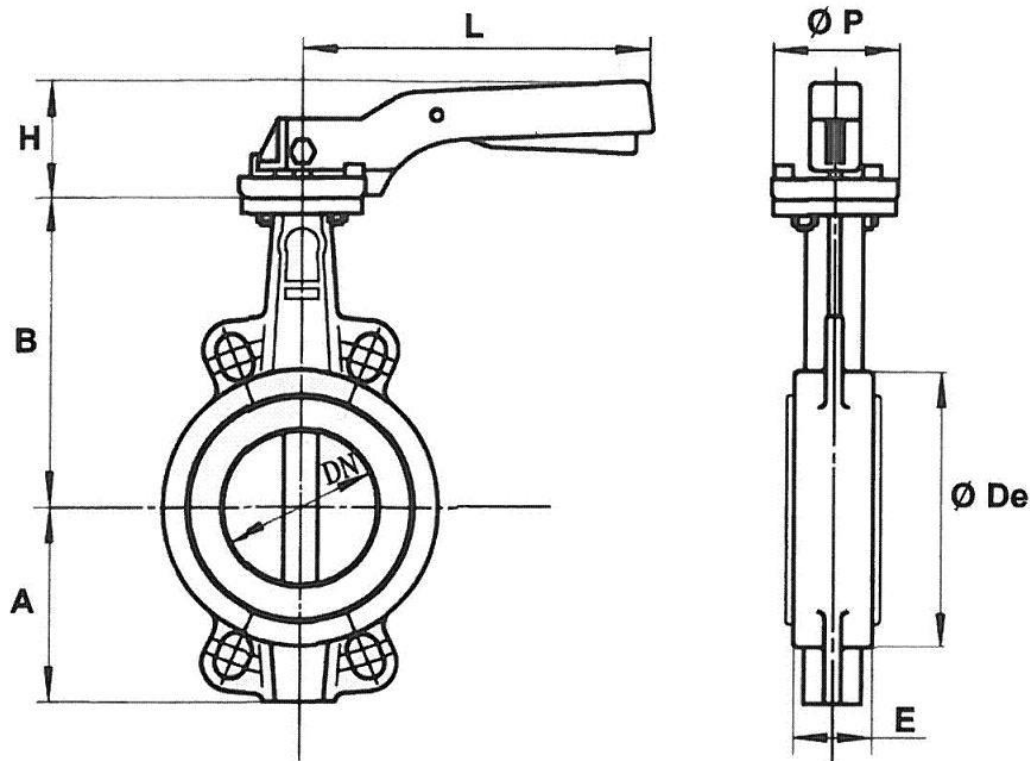

DN	40	50	65	80	100	125	150	200	250	300
A	61	77	87.5	95	107	121	144	171	205	235
B	130	136.5	142	158	180	192	215	242	280	310
Ø De	82	95	109	127	152	180	207	260	315	370
E	33	43	46	46	52	56	56	60	68	78
H	74	74	74	74	74	79	79	37	37	37
L	200	200	200	200	200	278	278	355	507	507
Ø P	65	65	65	65	65	90	90	125	150	150
Weight (kg)	1.8	2.5	2.9	3.2	4.2	6.7	7.7	14.7	23.4	33.8

## FLOW-RATE COEFFICIENT Kv (m<sup>3</sup>/h)

DN	40	50	65	80	100	125	150	200	250	300
Kv	78	98	167	258	512	872	1347	2675	4555	7037

Information given as an indication only, and subject to possible modifications



# 1121-1125 BUTTERFLY VALVES WITH AP RE PNEUMATIC ACTUATOR

## AP RE PNEUMATIC MOTORISATION

The ALPHAIR RE motorisation proposed as standard comprises:

- rack and pinion actuator of anodised aluminium.
- a safety coefficient of 1.3 minimum compared to the nominal torque of the valve.
- air non-lubricated dry motor, minimum 6 bar pressure.
- an upstream / downstream pressure difference  $\Delta P=10$  bar max.

The actuator assembly is of the following types:

- direct assembly with DN 32 to DN 200 aluminium motorisation mounting pad.
- yoke + stainless steel drive according to the EN 15081 standard for DN 250 to 300.

DN	Double-effect	V (litres)	Time (s)*	Spring-return	V (litres)	Time (s)*
40	RE 51	0.23	1	RES 64/6	0.45	1
50	RE 51	0.23	1	RES 64/6	0.45	1
65	RE 64	0.45	1	RES 76/6	0.61	1
80	RE 64	0.45	1	RES 76/6	0.61	1
100	RE 76	0.61	1	RES 101/6	1.80	2
125	RE 76	0.61	1	RES 101/6	1.80	2
150	RE 86	0.98	2	RES 116/6	2.80	2
200	RE 101	1.80	2	RES 126/6	3.70	3
250	RE 116	2.80	2	RES 146/6	4.90	3
300	RE 126	3.70	3	RES 181/6	11.1	5

For any other operating conditions, please contact us.

\*indicative time of the no-load actuator for opening or closing.

## MOTORISATION OPTIONS

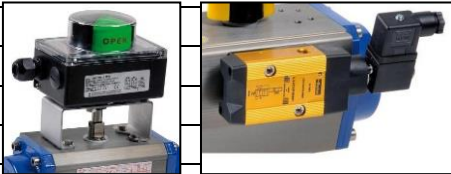
1	actuators dimensioned for a compressed air pressure of 3, 4 or 5 bar	
2	actuator dimensioned for an upstream / downstream pressure difference $\Delta P$ greater than 10 bar	
3	actuator with special coatings, stainless steel actuator	
4	Actuator for very low (-60°C) or very high (+150°C) ambient temperatures.	
5	manual override with declutchable gear box	
6	compressed air filter regulator	
7	All types of piloting solenoid valves	
8	all types of switch boxes	
9	all types of positioner	
10	rapid exhaust, flow-rate limiters - exhaust brakes	

Information given as an indication only, and subject to possible modifications

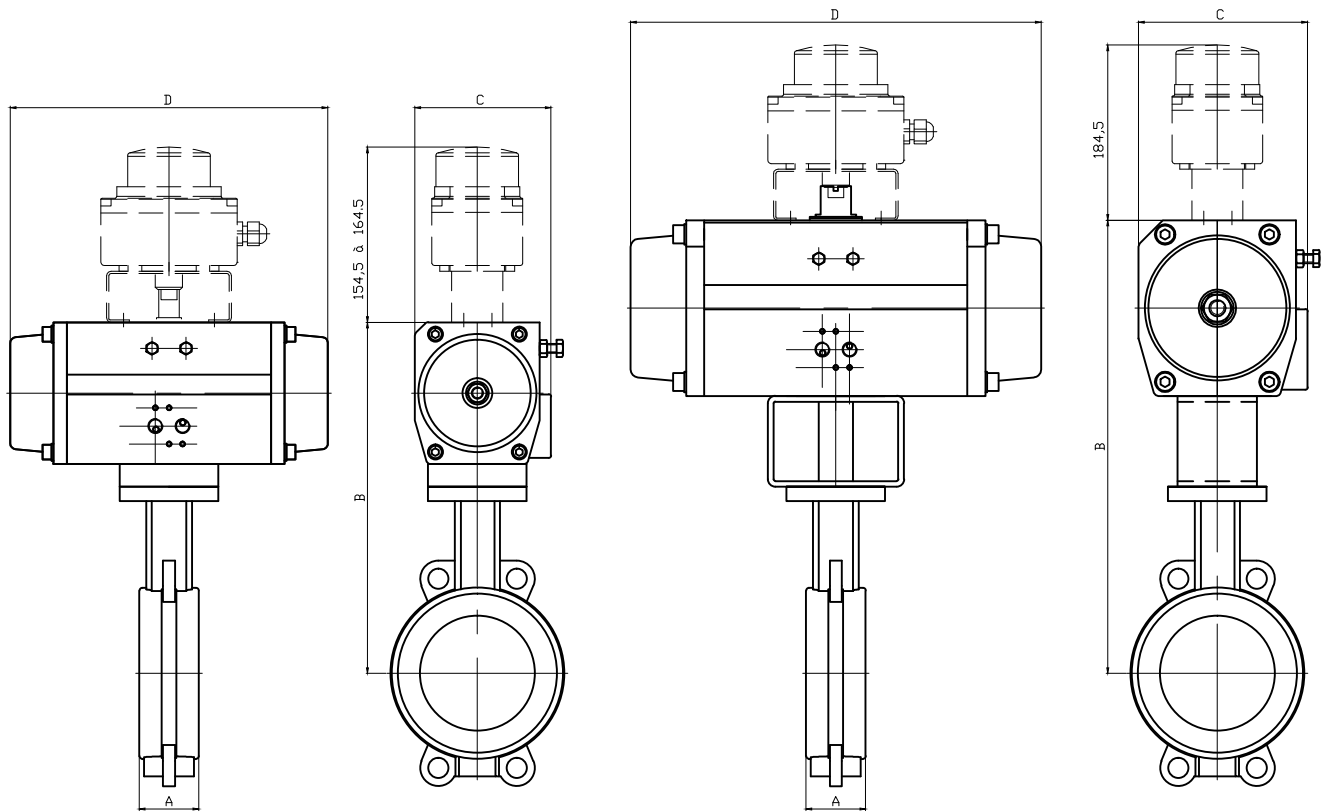

\* : montage avec platine H=80mm

DN	40		50		65		80		100	
ALPHAIR	51 RE	64 RES	51 RE	64 RES	64 RE	76 RES	64 RE	76 RES	76 RE	101RES
A	33		43		46		46		52	
B	219	236	226	243	248	264	264	280	302	327
C	75	86	75	86	86	94	86	94	94	120
D	138	155	138	155	155	203	155	203	203	261
KG	3.4	4.1	3.9	4.6	5	6.6	5.7	7.4	7.8	11.8

DN	125	150	200	250	300
----	-----	-----	-----	-----	-----