

1121-1125 BUTTERFLY VALVES + TCR ELECTRICAL ACTUATOR

FEATURES

1121 to 1125 butterfly valves are intended for the automatic opening /closing of different usual fluid pipes. The valve body is made of grey cast iron. The different configurations of the butterfly materials and of the liner make it suitable for different applications. Wafer mounting with centring ears between PN10/16 or ANSI 150 flanges. The long neck makes the mounting on thermally insulated pipe installations possible. The ISO 5211 mounting pad enables the TCR actuator to be directly assembled. The latter is suitable for S3-S4-type service factor, installed indoors or outdoors under shelter.



LIMITS OF USE

Fluid pressure: PS	16 bar up to DN 300
Fluid temperature: WT	According to the table below
Prohibited uses	Steam, natural gas
Ambient temperature	-20°C / +60°C
Service factor	S4 - 50% (TCR02N-05N-11N)
	S3 - 85% (TCR20N-40N)

AVAILABLE MODELS

DN 40 to DN 250.

Connection between flanges PN10/16 and ANSI 150 RF

Supply voltages: 24 VAC, 24 VDC and 230 VAC.

Ref.	Butterfly	Liner	Example of applications	WT° min	WT° max
1121	stainless steel	NBR	Liquid hydrocarbons - compressed air	-10°C	+90°C
1123	Stainless steel	EPDM	Demineralised water - alkalis	-10°C	+110°C
1125	cast iron	EPDM	Hot water - cold water	-10°C	+110°C

Information given as an indication only, and subject to possible modifications



1121-1125 BUTTERFLY VALVES + TCR ELECTRICAL ACTUATOR

DIRECTIVES AND MANUFACTURING STANDARDS

OBJECT	Standard	ON	OBJECT	Standard
Pressure Equipment Directive 2014/68/EC	Cat. III module H	0035	Final test	API 598
Face-to-face dimension	ISO 5752 series 20		Actuator pilot connection	NAMUR
Flange dimension	EN 1092-1		Switch box connection	VDI/VDE 3845
Connection Motorisation	ISO 5211:		SIL 3 level (the actuator alone)	NKS 61508

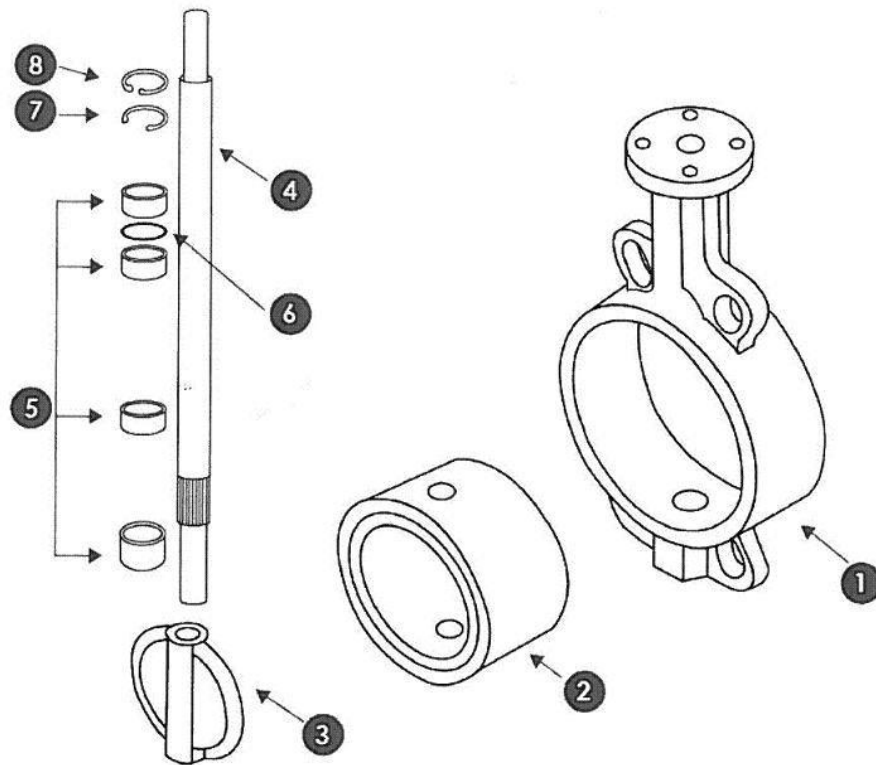

CONSTRUCTION

No.	Name	1121	1123	1125
1	Body	EN GJL-250 grey cast iron		
2	Liner	NBR	EPDM	EPDM
3	Butterfly	1.4408 SS	1.4408 SS	EN GJS-400-15 nickel-plated cast iron
4	Crossing stem	416 SS		
5	Bearings	PTFE		
6	O-ring	NBR	NBR	NBR
7	Circlips	Steel		
8	Circlips	Steel		

Information given as an indication only, and subject to possible modifications

1121-1125 BUTTERFLY VALVES + TCR ELECTRICAL ACTUATOR

DIMENSIONS (mm)

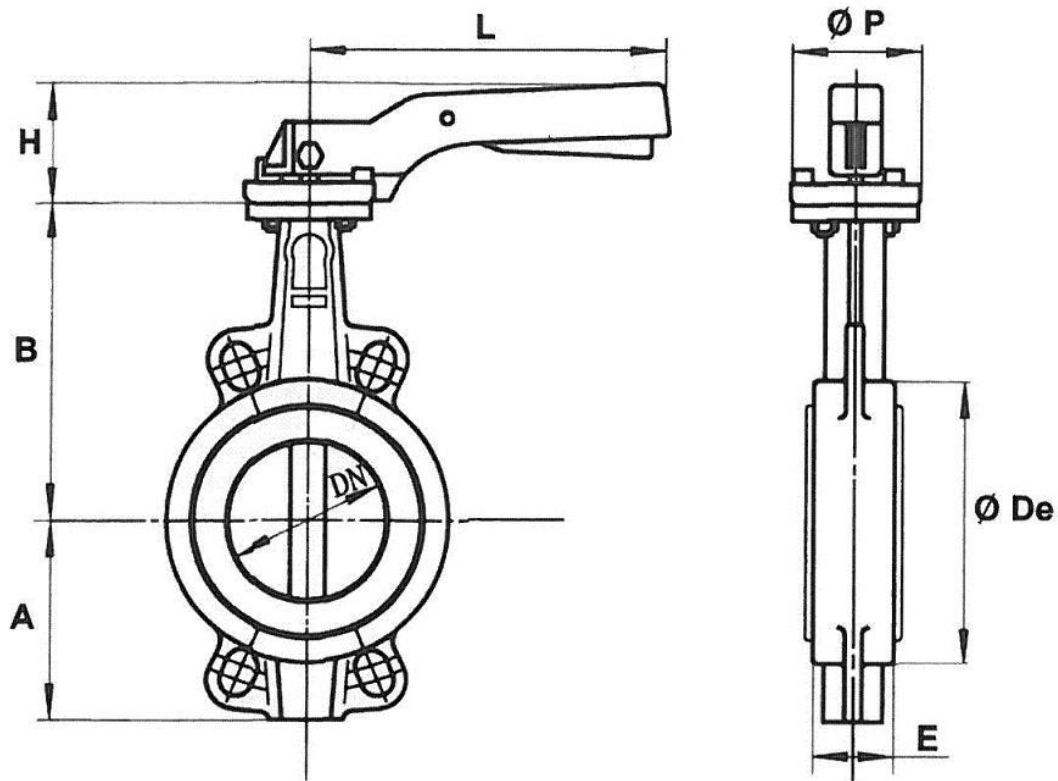

DN	40	50	65	80	100	125	150	200	250	300
A	61	77	87.5	95	107	121	144	171	205	235
B	130	136	142	158	180	192	215	242	280	310
Ø De	82	95	109	127	152	180	207	260	315	370
E	33	43	46	46	52	56	56	60	68	78
H	74	74	74	74	74	79	79	37	37	37
L	200	200	200	200	200	278	278	355	507	507
Ø P	65	65	65	65	65	90	90	125	150	150
Weight (kg)	1.8	2.5	2.9	3.2	4.12	6.7	7.8	14.2	23.4	33.8

FLOW-RATE COEFFICIENT Kv (m³/h)

DN	40	50	65	80	100	125	150	200	250	300
Kv	78	98	167	258	512	872	1347	2675	4555	7037

Information given as an indication only, and subject to possible modifications

1121-1125 BUTTERFLY VALVES + TCR ELECTRICAL ACTUATOR

TCR ELECTRICAL MOTORISATION

The TCR motorisation proposed as standard comprises:

- IP67 plastic housing for actuator and steel gear box,
- a safety coefficient of 1.3 minimum compared to the nominal torque of the valve,
- an upstream / downstream pressure difference $\Delta P=10$ bar max.

The actuator's assembly is direct.

DN	Actuator	Power 230V AC / 24V AC/DC	Time 230V AC	Time 24 V AC-DC	Standard equipment of the actuator
40	TCR-05N	25	12s	12s	2 adjustable limit switches 2 dry auxiliary contacts Thermal protection of the motor 2-3W anti-condensation resistance Stand-by manual control with key 3D Position visual indicator Electrical connection: TCR05: 1 x PE M20 + 1.5m cable TCR11: 2 x PE M14 + 1.5m cable TCR20: 2 x PE M20 + 1.5m cable TCR40: 2 x PE M20 + 1.5m cable
50	TCR-05N	25	12s	12s	
65	TCR-05N	25	12s	12s	
80	TCR-05N	25	12s	12s	
100	TCR-11N	100	10s	10s	
125	TCR-11N	100	10s	10s	
150	TCR-20N	50	25s	25s	
200	TCR-40N	80	25s	25s	
250	TCR-40N	80	25s	25s	

For any other operating conditions, please contact us.

* indicative time for actuator running empty

MOTORISATION OPTIONS

There are many options, so please contact our sales service for more information on these:

1	NF actuator – return via condenser – TCR-KT32
2	High-speed actuator - TRC-NH
3	Smart actuator with manoeuvring time adjustment - TCR-C
4	Control actuator – TCR-T
5	NF control actuator – return via condenser – TCR-T-KT32
6	Field bus actuator - TCR-B
7	Actuator with in-built timer – TCR-D
8	Wireless actuator – TCR-R

Information given as an indication only, and subject to possible modifications



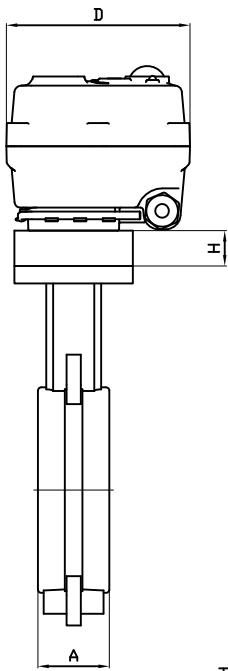

TCR-05

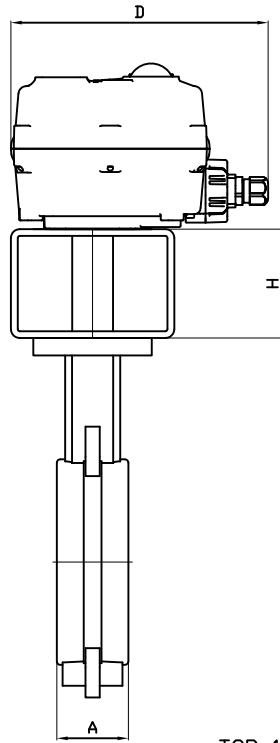
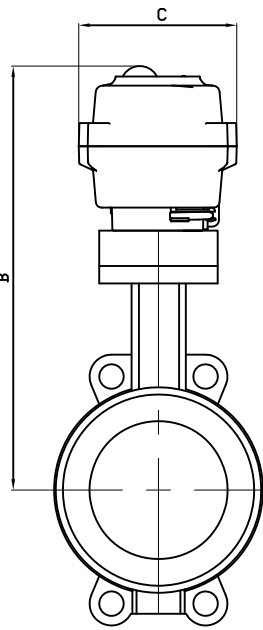

TCR-11-20-40

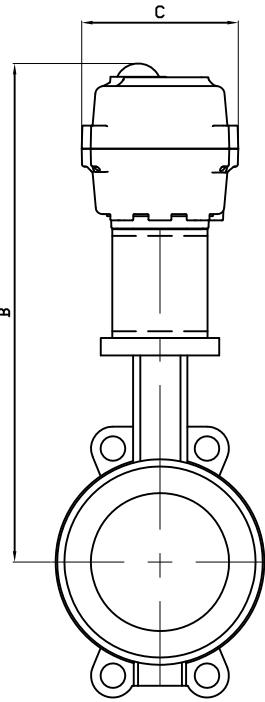

DN	40	50	65	80	100	125
SERVO	TCR05	TCR05	TCR05	TCR05	TCR11	TCR11
A	33	43	46	46	52	56
B	277	283.5	289	305	328	340
C	111	111	111	111	115	115
D	132	132	132	132	165	165
H	26	26	26	26	26	26
KG	3.9	4.4	5	5.7	7.9	9.5

DN	150	200	250
SERVO	TCR20	TCR40	TCR40
A	56	60	68
B	413	429	532
C	160	160	160
D	270	270	270
H	26	15	80
KG	14.6	19.1	35.9

TCR-N ELECTRICAL ACTUATOR

FEATURES

The TCR-N electric actuators are intended for motorising ¼ turn valves with a torque of 15, 20, 50, 110, 200 or 400 Nm. With a compact construction and plastic housing, they are especially well suited for motorising ball valves and butterfly valves. Several variants offer advanced functions. IP67 leak-tightness: to be used indoors and, possibly, outdoors under a shelter. Possible installation in parallel. Manual control with a key.

AVAILABLE MODELS

Supply voltages: 230V AC, 24V AC/DC, 12V DC.



LIMITS OF USE

IP Code	IP 67
Ambient temperature	- 20°C / +60°C
Service factor	S4 - 50% (TCR 02-05-11)
	S3 - 85% (TCR 20-40)

MECHANICAL FEATURES

Gear box	treated steel pinions
Torques	15 - 20 - 50 - 110 - 200 - 400 Nm
Angle of rotation	90° +/- 2°
Declutching	Without (TCR 02-05-11)
	With (TCR 20-40)
Override control	By key



Actuator	TCR 02N			TCR 05N		
	Torques (Nm)	15	20	20	50	
Voltage	12V DC	24V AC-DC	95-265V AC-DC	12VDC	24V AC-DC	95-265V AC-DC
Manoeuvring time (s)	15	10	10	12	12	12
ISO 5211:	F03/F05 - star 11			F05/F07 - star 14		

Actuator	TCR 11N			TCR 20N			TCR 40N		
	Torques (Nm)	110			200			400	
Voltage	12V DC	24V AC-DC	95-265V AC-DC	12VDC	24V AC-DC	95-265V AC-DC	12V DC	24V AC-DC	95-265V AC-DC
Manoeuvring time (s)	10	10	10	25	25	25	25	25	25
ISO 5211:	F05/F07 - star 17			F07/F10 - star 22			F07/F10 - star 22		

Information given as an indication only, and subject to possible modifications



TCR-N ELECTRICAL ACTUATOR

ELECTRICAL FEATURES

Actuator	TCR 02N	TCR 05N
Motor protection	Thermal switch	
Limit switches	2 adjustable switches	
Auxiliary switches	2 adjustable dry switches	
Anti-condensation	integrated	
Electrical connection	PE M10 + 1.5m cable	PE M20 + 1.5m cable

Actuator	TCR 02N			TCR 05N		
Voltage	12V DC	24V AC-DC	95-265V AC-DC	12V DC	24V AC-DC	95-265V AC-DC
Power (W)	15	15	15	25	25	25
Current (A)	1,5	1,5	0,09	1,67		0,18 - 0,37
Fuse Protection (A)	5	5	1	8		1 - 2

Actuator	TCR 11N	TCR 20N	TCR 40N
Motor protection	Thermal switch		
Limit switches	2 adjustable switches		
Auxiliary switches	2 adjustable dry switches		
Anti-condensation	Integrated		
Electrical connection	2 x PE M14 + 1,5m cable	2 x PE M20 + 1.5m cable	2 x PE M20 + 1,5m cable

Actuator	TCR 11N			TCR 20N			TCR 40N		
Voltage	12V DC	24V AC-DC	95-265V AC-DC	12V DC	24V AC-DC	95-265V AC-DC	12V DC	24V AC-DC	95-265V AC-DC
Power (W)	100	100	100	50	50	50	80	80	80
Current (A)	2,5		0,3 – 0,6	2		0,22	3,3		0,36
Fuse Protection (A)	5		2 - 3	3		5	8		2

Information given as an indication only, and subject to possible modifications



TCR-N ELECTRICAL ACTUATOR

CONSTRUCTION (TCR-02N)

TCR-02N					
No.	Name	Material	No.	Name	Material
1	Casing + lid	Plastic (ABS)	6	Rating plate	PVC
2	Position indicator	Polycarbonate plastic	7	Key support	Plastic (ABS)
3	Screw x 4	Aisi 304	8	Hex key	Steel
4	Backup control stem	Aisi 304	9	Packing gland	Nylon
5	Gasket	NBR	10	Cover gasket	NBR

Weight (kg): 0.620

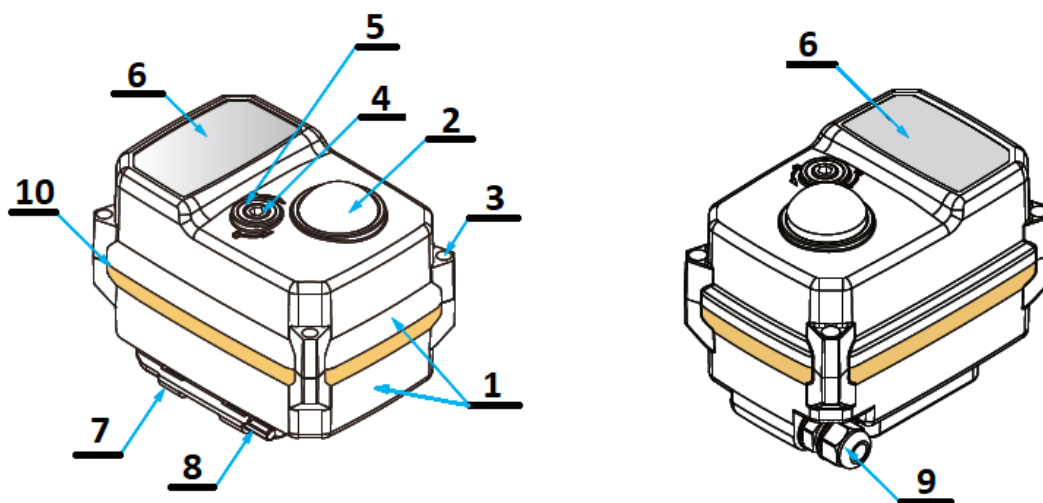

DIMENSIONS (mm)

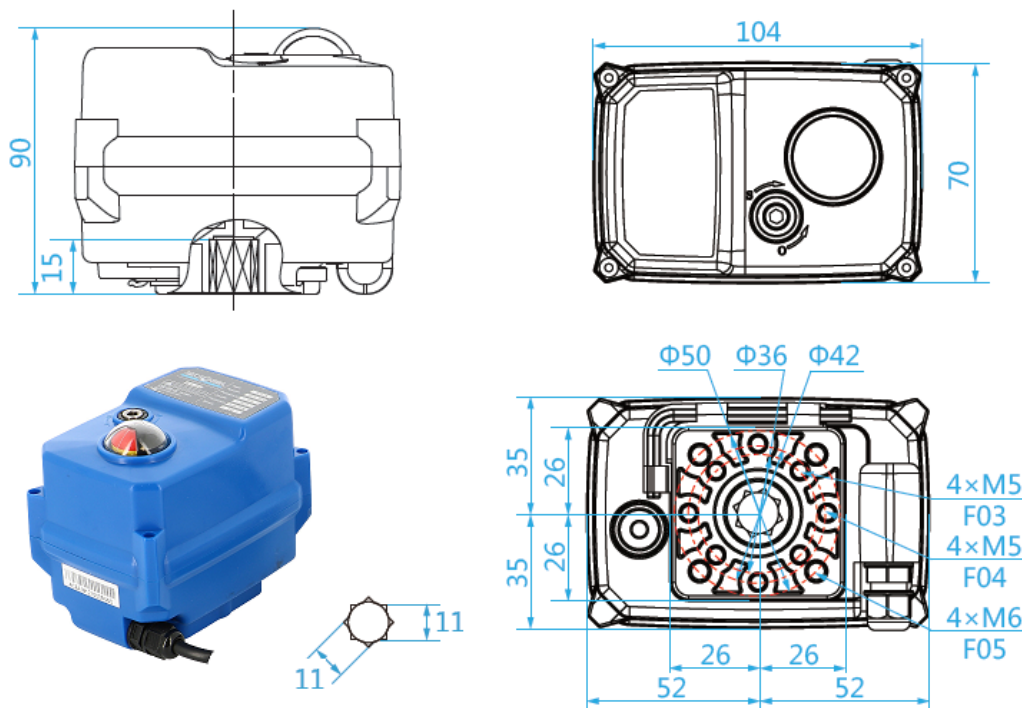

Information given as an indication only, and subject to possible modifications

TCR-N ELECTRICAL ACTUATOR

CONSTRUCTION (TCR-05N)

TCR-05N					
No.	Name	Material	No.	Name	Material
1	Casing + lid	Plastic (ABS)	6	Rating plate	PVC
2	Position indicator	Polycarbonate plastic	7	Key support	Plastic (ABS)
3	Screw x 6	Aisi 304	8	Hex key	Steel
4	Backup control stem	Aisi 304	9	Packing gland	Nylon
5	Gasket	NBR	10	Cover gasket	NBR

Weight (kg): 1.800

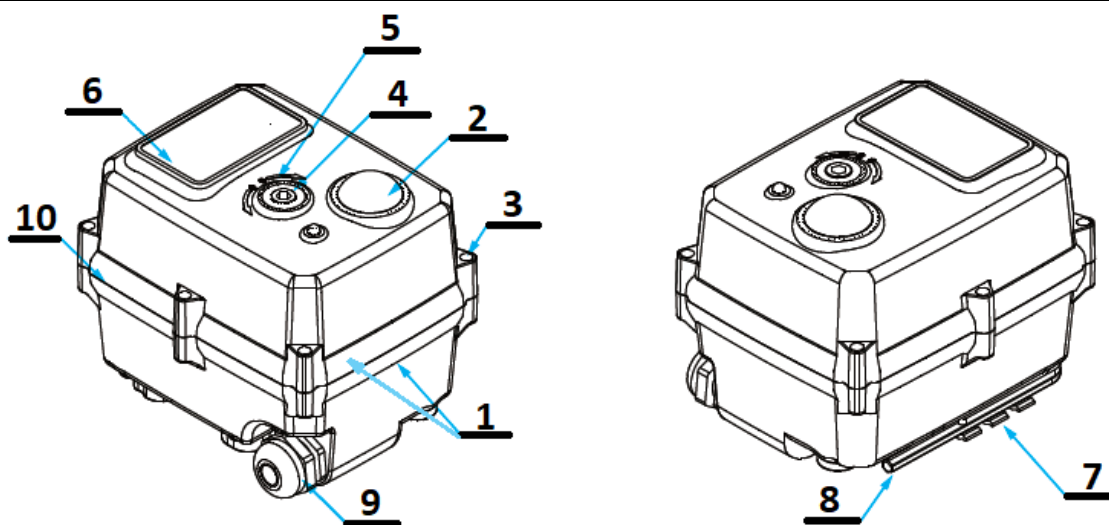

DIMENSIONS (mm)

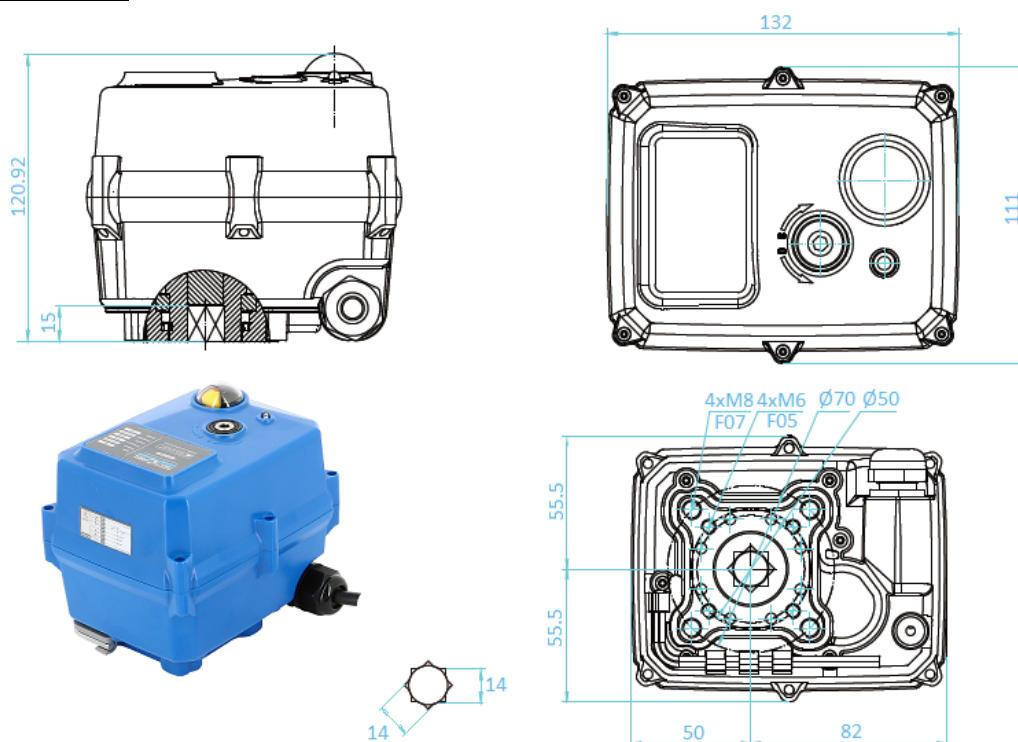

Information given as an indication only, and subject to possible modifications

TCR-N ELECTRICAL ACTUATOR

CONSTRUCTION (TCR-11N)

TCR-11N					
No.	Name	Material	No.	Name	Material
1	Casing + lid	Plastic (ABS)	6	Rating plate	PVC
2	Position indicator	Polycarbonate plastic	7	Key support	Plastic (ABS)
3	Screw x 6	Aisi 304	8	Hex key	Steel
4	Backup control stem	Aisi 304	9	X 2Packing gland	Nylon
5	Gasket	NBR	10	Cover gasket	NBR
Weight (kg): 2.200			11	Cable gland unit	Plastic (ABS)

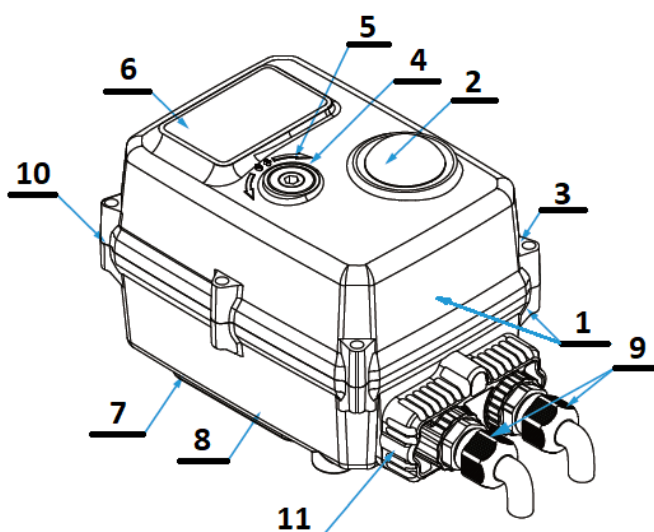

DIMENSIONS (mm)

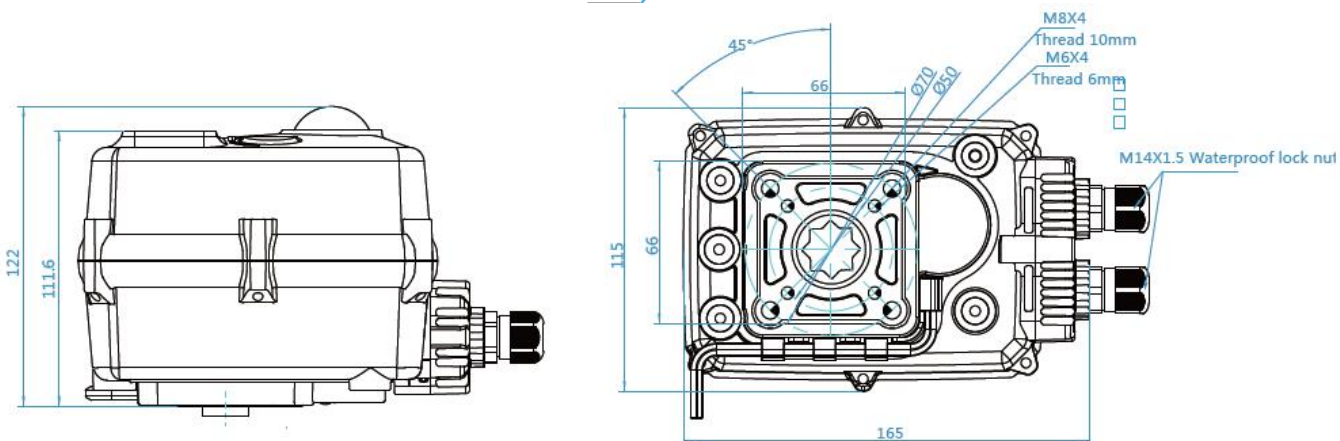

Information given as an indication only, and subject to possible modifications

TCR-N ELECTRICAL ACTUATOR

CONSTRUCTION (TCR-20N / TCR-40N)

TCR-20N / TCR-40N					
No.	Name	Material	No.	Name	Material
1	Casing + lid	PC + PET	6	Clutch	Polyoxymethylene POM
2	Position indicator	Polycarbonate plastic	7	Key support	Plastic ABS
3	Screw x 6	Aisi 304	8	Hex key	Steel
4	Backup control stem	Aisi 304	9	X 2Packing gland	Nylon
5	LED	Transparent PC	10	Cover gasket	NBR
Weight (Kg) : 6,000			11	Cable gland unit	Plastic ABS

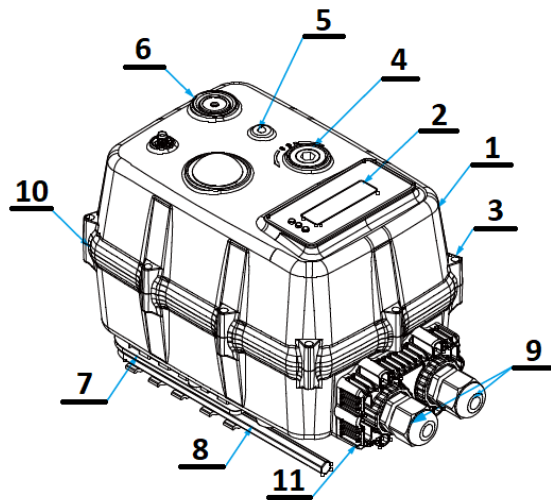

DIMENSIONS (mm)

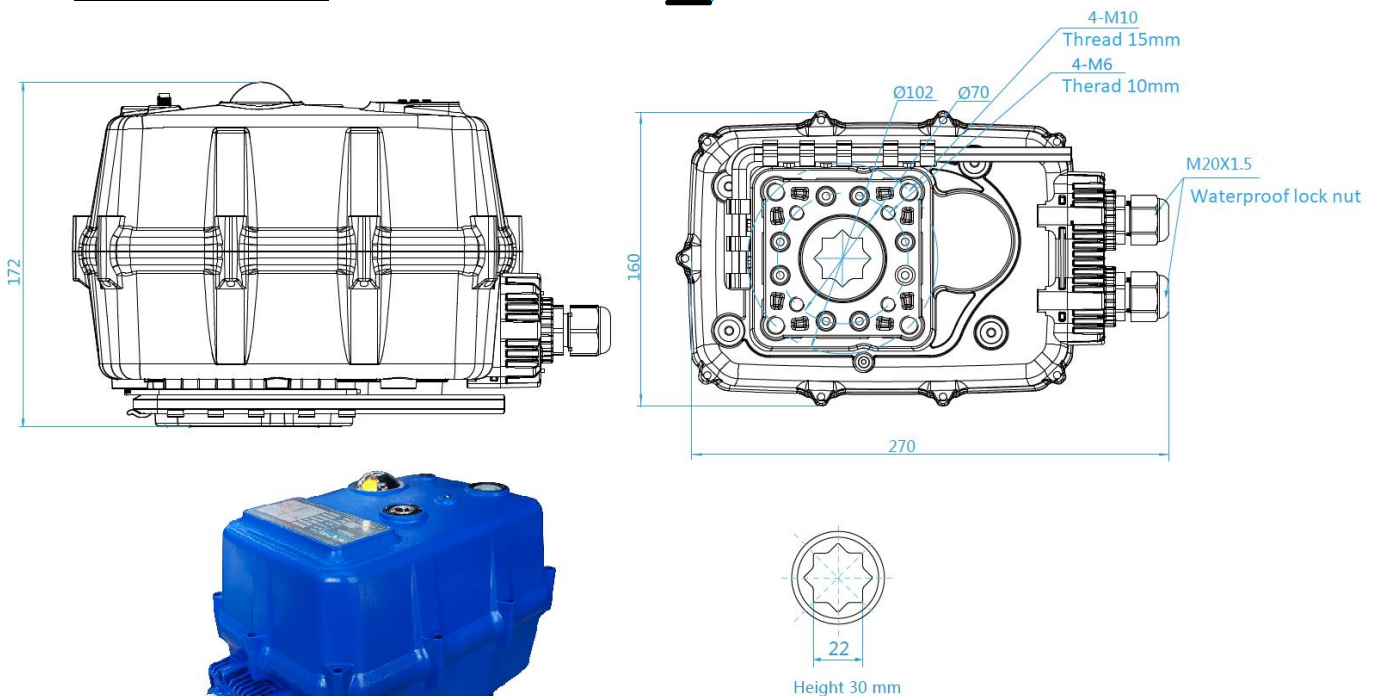

Information given as an indication only, and subject to possible modifications

TCR-N ELECTRICAL ACTUATOR

WIRING DIAGRAM

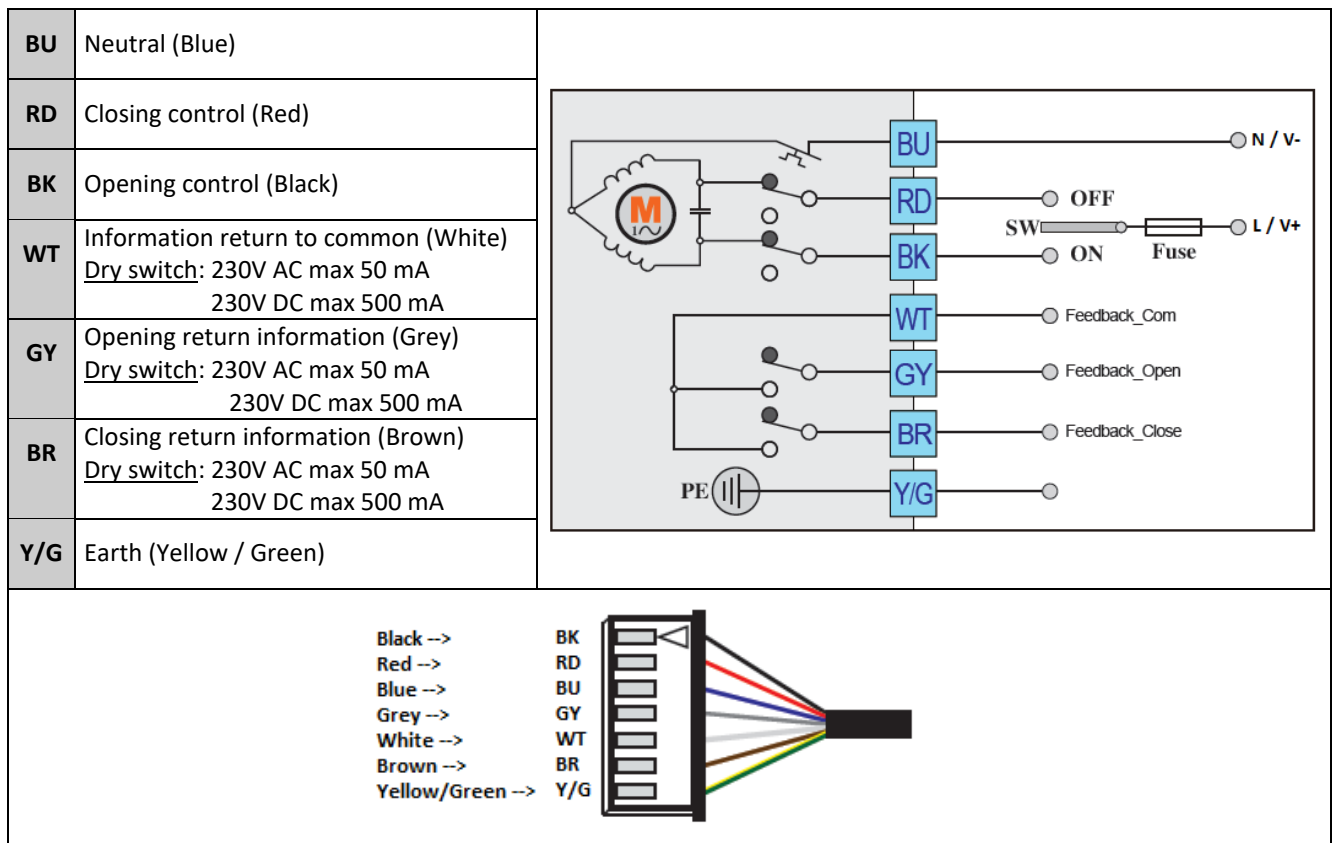

SWITCH SETTING

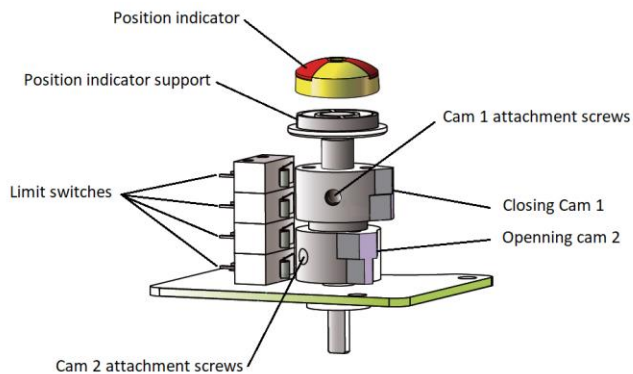

GENERAL VIEW

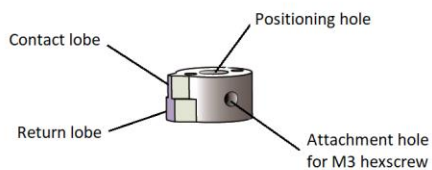

CAM DETAIL

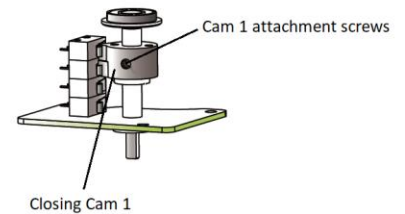

CLOSING CAM ADJUSTMENT

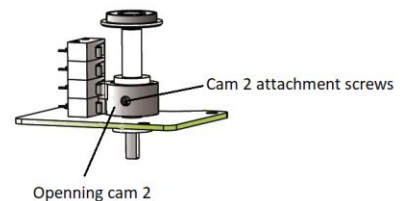

OPENING CAM ADJUSTMENT

Information given as an indication only, and subject to possible modifications

TCR-N ELECTRICAL ACTUATOR

TROUBLESHOOTING

Defect met	Cause of defect	Method of solving
Inactive actuator	Non-connected electrical grid.	Connect to the electrical grid.
	Wrong voltage.	Check the actuator's voltage.
	Motor overheating.	Check the torque on the valve.
	Faulty connection.	Check the connection to the terminal box.
	Damaged start capacitor.	Contact the supplier for repair.
No switch signal	Faulty connection.	Check the connections.
	Damaged microswitch	Change the microswitch
Valve that is not fully closed	Use the return signal from the actuator check.	Receiving a return signal does not mean that the actuator is fully closed, hence do not cut the power supply.
	The hysteresis increases due to wear or between the actuator and the valve's stem.	Readjust the limit cams. Contact the supplier for repair.
Presence of humidity or water in the actuator	Unsuitable cable cross-section being used.	Contact the supplier for repair.
	The cable connection is not leak-tight.	
	Worn sealing gaskets.	
	Loose cover screws.	Dry the internal parts and tighten the cover screws.

Information given as an indication only, and subject to possible modifications



SERVOMOTEUR ELECTRIQUE RETOUR CONDENSATEUR TCR-N-KT

CARACTERISTIQUES GENERALES

Les servomoteurs électriques TCR-N-KT sont destinés à la motorisation des robinets 1/4 de tour avec un couple de manœuvre de 15, 50, 90 ou 200 Nm. **Fonction retour condensateur** : la manœuvre de fermeture est assurée par un condensateur. De construction compacte avec un carter en plastique, ils sont particulièrement bien adaptés à la motorisation des robinets à tournant sphérique de petites dimensions. Etanchéité **IP67** : utilisation en intérieur et possible en extérieur sous abri. Montage en parallèle possible. Commande manuelle par clef.

MODELES DISPONIBLES

Tensions d'alimentation : 230Vca, 24Vca/cc.

LIMITES D'EMPLOI

Indice de protection	IP 67
Température ambiante	- 20°C / +60°C
Facteur de service	S4 - 50% (TCR 02N-05N-11N)
	S3 - 85% (TCR 20N)



CARACTERISTIQUES MECANIQUES

Réducteur	pignons en acier traité
Couples	15 - 50 - 90 - 200 Nm
Angle de rotation	90° +/- 2°
Débrayage	Sans (TCR 02N-05N-11N)
	Avec (TCR 20N)
Commande de secours	par clef

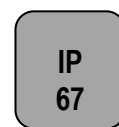

Servomoteur	TCR 02N-KT32		TCR 05N-KT32		TCR 11N-KT32	
Couples (Nm)	15		50		90	
Tension	24Vca-cc	95-265Vca-cc	24Vca-cc	95-265Vca-cc	24Vca-cc	95-265Vca-cc
Tps de manœuvre (s)	10	10	12	12	10	10
ISO 5211	F03/F05 - étoile de 11		F05/F07- étoile de 14		F05/F07- étoile de 17	

Servomoteur	TCR 20N-KT32	
Couples (Nm)	200	
Tension	24Vca-cc	95-265Vca-cc
Tps de manœuvre (s)	25	25
ISO 5211	F07/F10 - étoile de 22	

Informations données à titre indicatif et sous réserve de modifications éventuelles

SERVOMOTEUR ELECTRIQUE RETOUR CONDENSATEUR TCR-N-KT

CARACTERISTIQUES ELECTRIQUES

Servomoteur	TCR 02N-KT32	TCR 05N-KT32	TCR 11N-KT32
Protection du moteur	Limiteur thermique		
Contacts fins de course	2 contacts réglables		
Contacts auxiliaires	2 contacts secs réglables		
Anti-condensation	Intégré		
Raccordement électrique	PE M10 + Câble 1,5m	PE M20 + Câble 1,5m	2 x PE M14 + Câble 1,5m

Servomoteur	TCR 02N-KT32		TCR 05N-KT32		TCR 11N-KT32	
Tension	24Vca-cc	95-265Vca-cc	24Vca-cc	95-265Vca-cc	24Vca-cc	95-265Vca-cc
Puissance (W)	36	36	40	40	100	100
Intensité (A)	1,5	0,09	1,8	1,6	2,5	0,26 - 0,52
Protection fusible (A)	5	1	10	2	5	2

Servomoteur	TCR 20N-KT32
Protection du moteur	Limiteur thermique
Contacts fins de course	2 contacts réglables
Contacts auxiliaires	2 contacts secs réglables
Anti-condensation	Intégré
Raccordement électrique	PE M20 + Câble 1,5m

Servomoteur	TCR 20N-KT32	
Tension	24Vca-cc	95-265Vca-cc
Puissance (W)	50	50
Intensité (A)	2	0.22
Protection fusible (A)	2	5

Informations données à titre indicatif et sous réserve de modifications éventuelles



SERVOMOTEUR ELECTRIQUE RETOUR CONDENSATEUR TCR-N-KT

CONSTRUCTION (TCR-02N-KT32)

TCR-02N-KT32					
N°	Désignation	Matière	N°	Désignation	Matière
1	Carter + couvercle	Plastique en ABS	6	Etiquette signalitique	PVC
2	Indicateur de position	Plastique polycarbonate	7	Support clef	Plastique en ABS
3	Vis x 4	Aisi 304	8	Clef hexagonale	Acier
4	Axe cde de secours	Aisi 304	9	Presse-étoupe	Nylon
5	Joint	NBR	10	Joint capot	NBR
Poids (Kg) : 0,620					

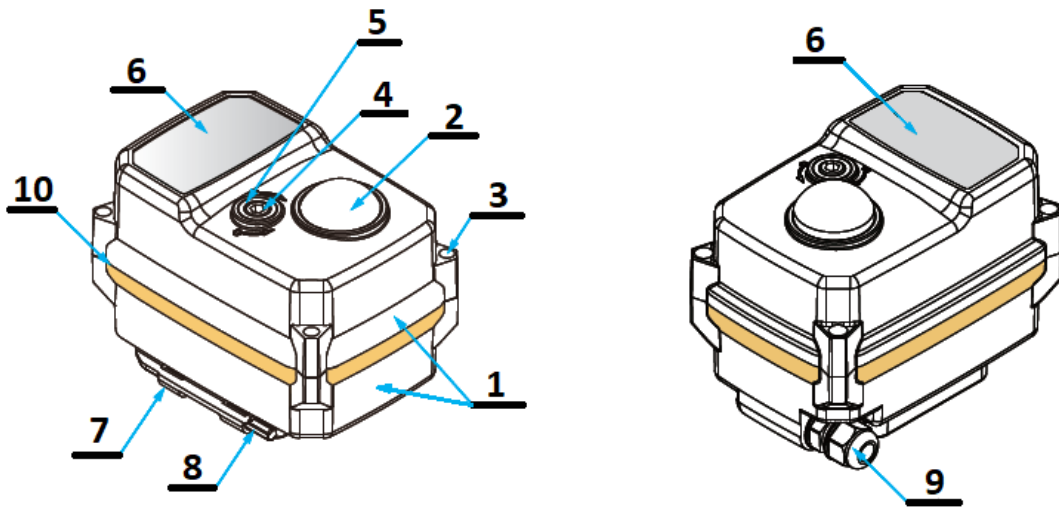

DIMENSIONS (mm)

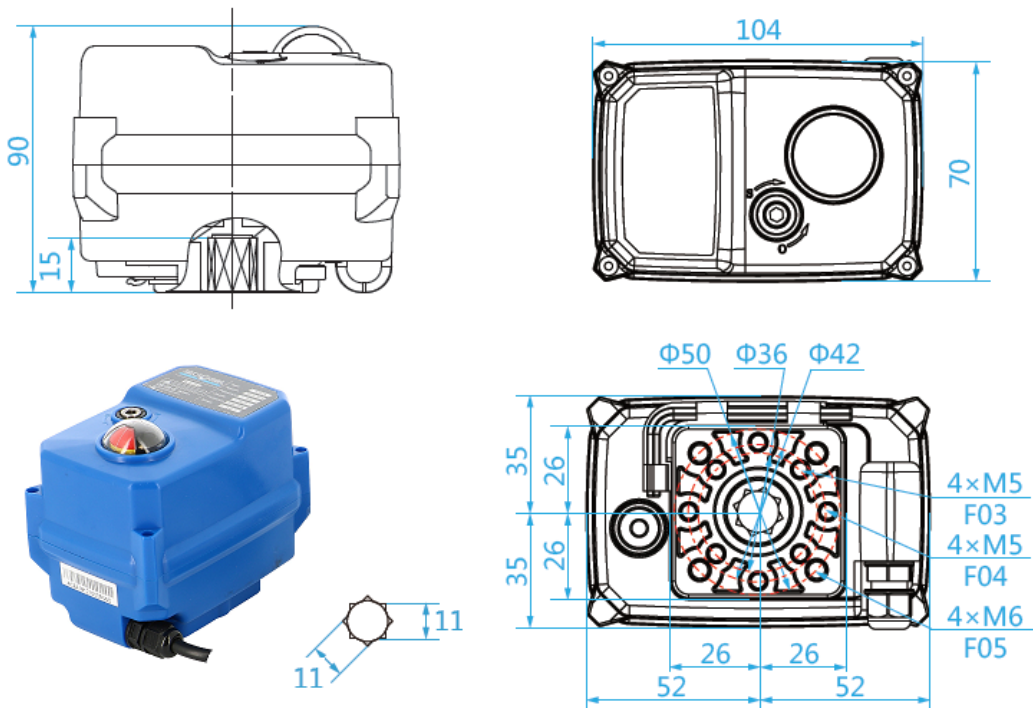

Informations données à titre indicatif et sous réserve de modifications éventuelles

SERVOMOTEUR ELECTRIQUE RETOUR CONDENSATEUR TCR-N-KT

CONSTRUCTION (TCR-05N-KT32)

TCR-05N-KT32					
N°	Désignation	Matière	N°	Désignation	Matière
1	Carter + couvercle	Plastique en ABS	6	Etiquette signalitique	PVC
2	Indicateur de position	Plastique polycarbonate	7	Support clef	Plastique en ABS
3	Vis x 6	Aisi 304	8	Clef hexagonale	Acier
4	Axe cde de secours	Aisi 304	9	Presse-étoupe	Nylon
5	Joint	NBR	10	Joint capot	NBR
Poids (Kg) : 1,800					

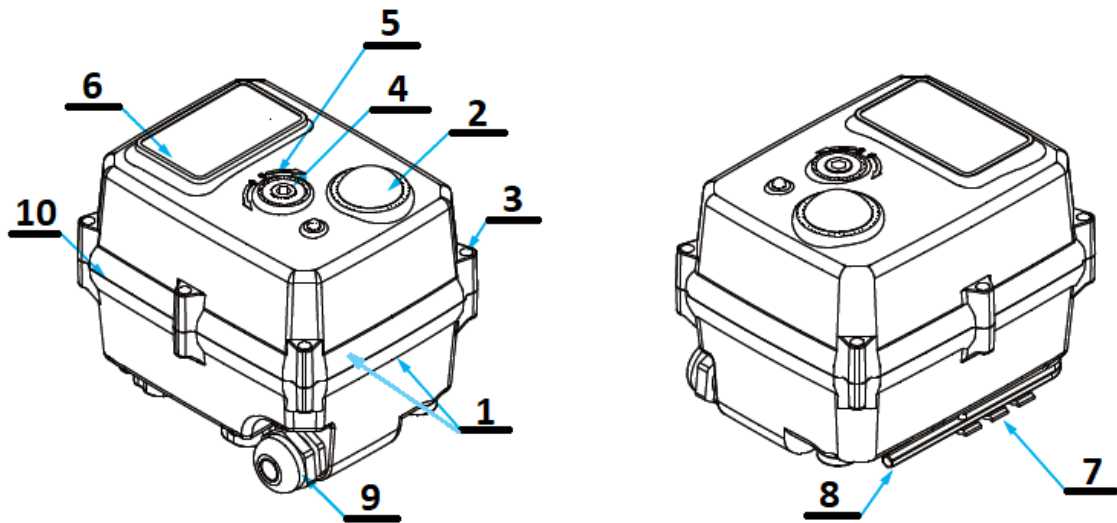

DIMENSIONS (mm)

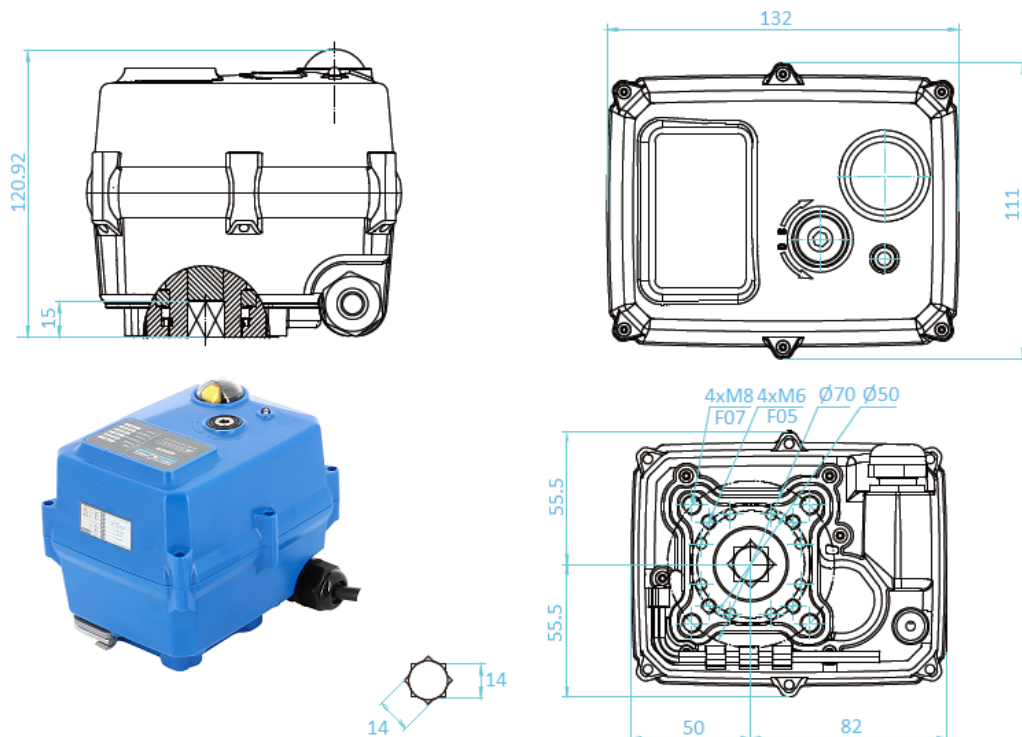

Informations données à titre indicatif et sous réserve de modifications éventuelles

SERVOMOTEUR ELECTRIQUE RETOUR CONDENSATEUR TCR-N-KT

CONSTRUCTION (TCR-11N-KT32)

TCR-11N-KT32					
N°	Désignation	Matière	N°	Désignation	Matière
1	Carter + couvercle	Plastique en ABS	6	Etiquette signalitique	PVC
2	Indicateur de position	Plastique polycarbonate	7	Support clef	Plastique en ABS
3	Vis x 6	Aisi 304	8	Clef hexagonale	Acier
4	Axe cde de secours	Aisi 304	9	Presse-étoupe x 2	Nylon
5	Joint	NBR	10	Joint capot	NBR
Poids (Kg) : 2,200			11	Bloc presse-étoupe	Plastique en ABS

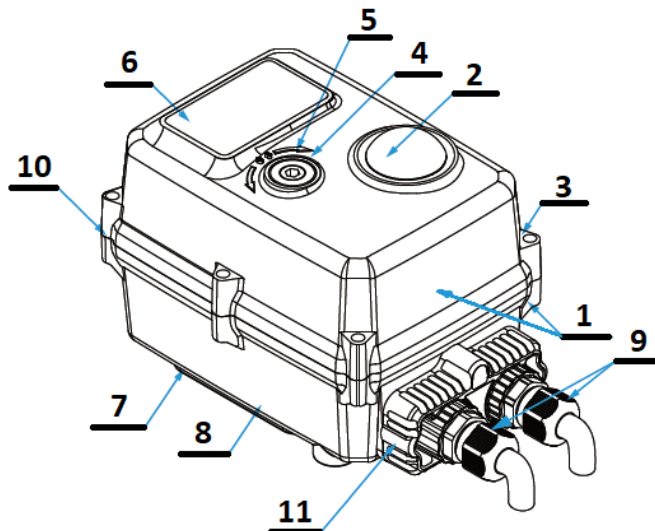

DIMENSIONS (mm)

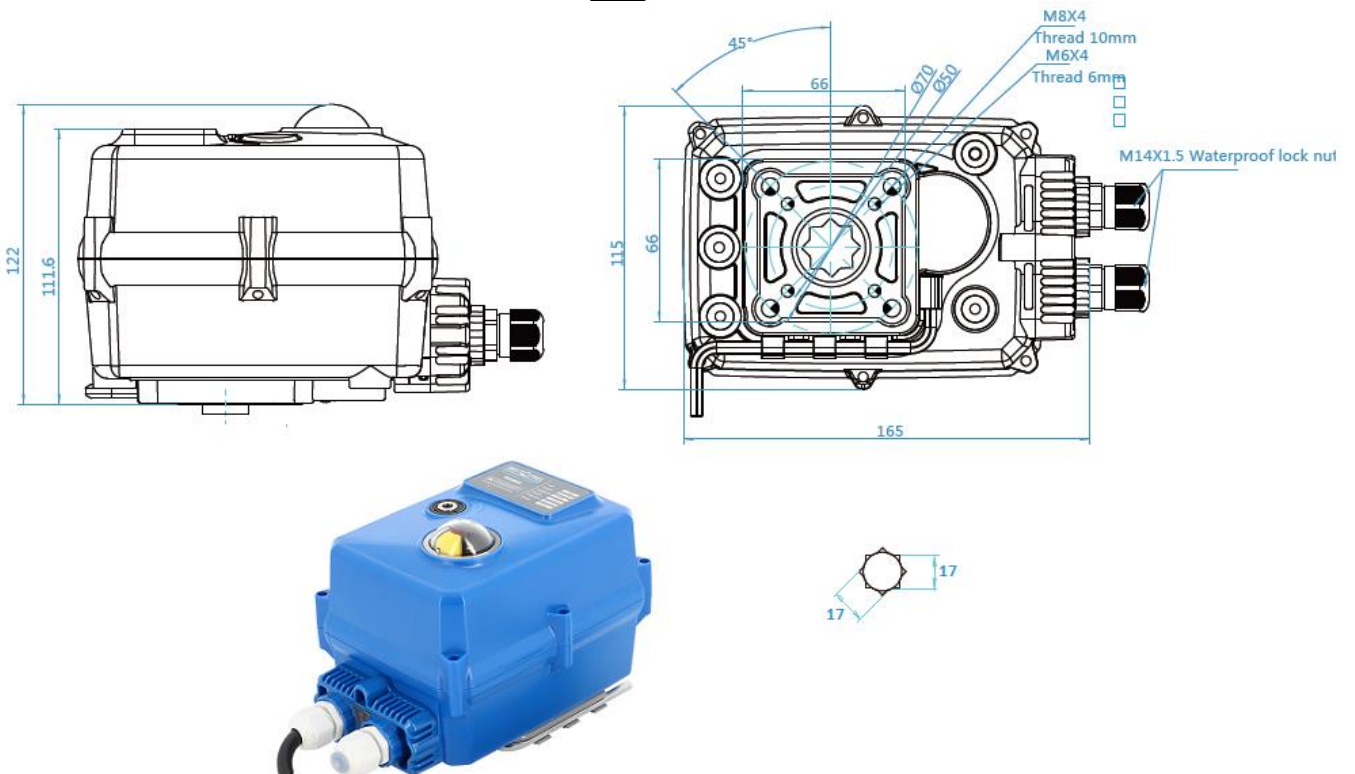

Informations données à titre indicatif et sous réserve de modifications éventuelles

SERVOMOTEUR ELECTRIQUE RETOUR CONDENSATEUR TCR-N-KT

CONSTRUCTION (TCR-20N-KT32)

TCR-20N-KT32					
N°	Désignation	Matière	N°	Désignation	Matière
1	Carter + couvercle	PC + PET	6	Débrayage	Polyoxyméthylène POM
2	Indicateur de position	Plastique polycarbonate	7	Support clef	Plastique en ABS
3	Vis x 6	Aisi 304	8	Clef hexagonale	Acier
4	Axe cde de secours	Aisi 304	9	Presse-étoupe x 2	Nylon
5	LED	Plastique PC	10	Joint capot	NBR
Poids (Kg) : 6,000			11	Bloc presse-étoupe	Plastique en ABS

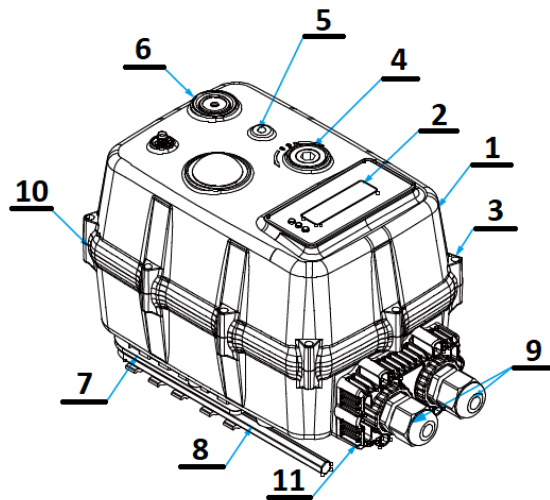

DIMENSIONS (mm)

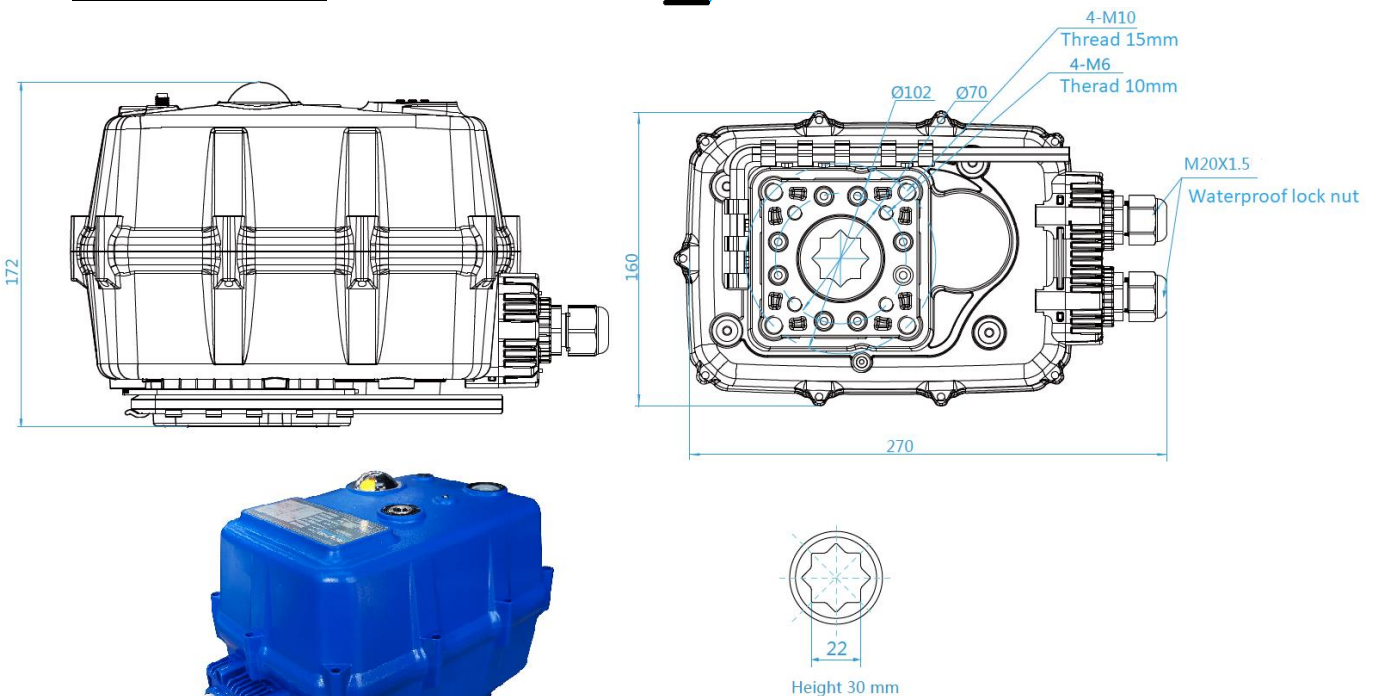

Informations données à titre indicatif et sous réserve de modifications éventuelles

SERVOMOTEUR ELECTRIQUE RETOUR CONDENSATEUR TCR-N-KT

SCHEMA DE CABLAGE

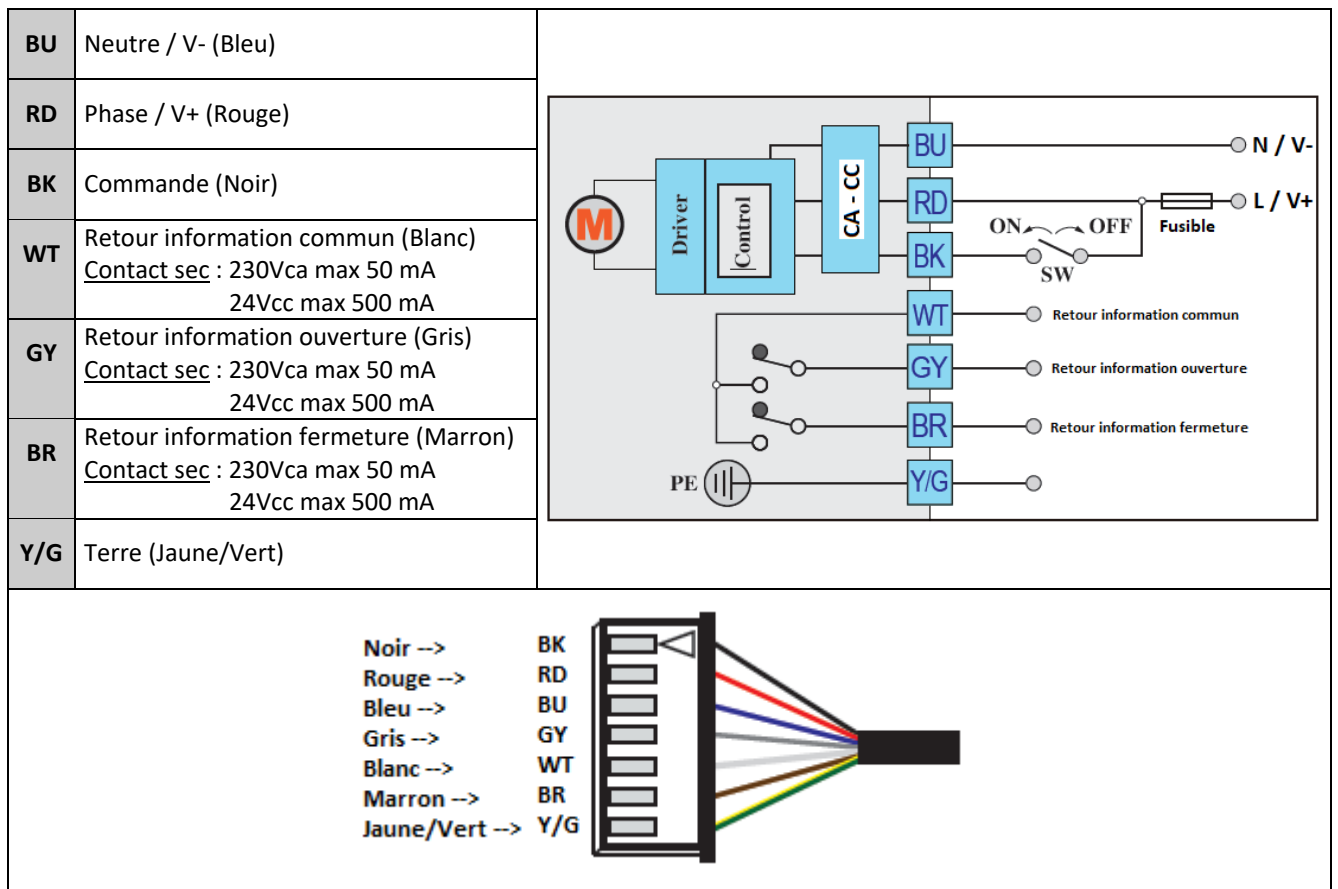

REGLAGE DES FINS DE COURSE

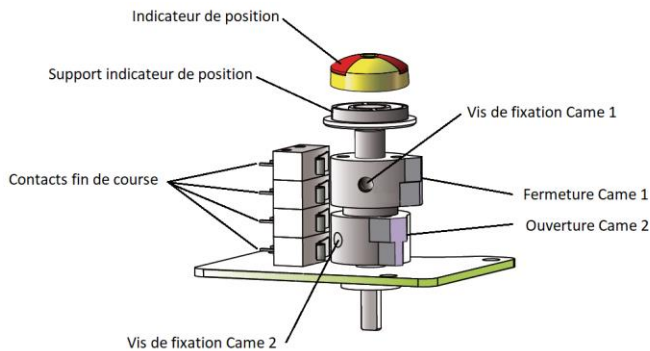

VUE GENERALE

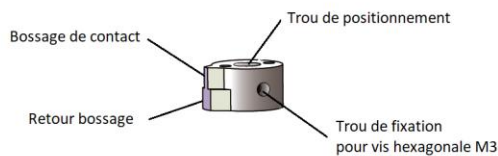

DETAIL DE LA CAME

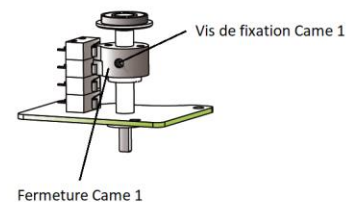

REGLAGE CAME FERMETURE

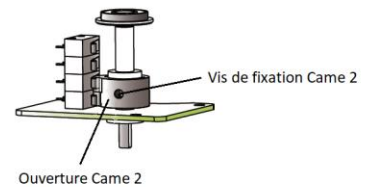

REGLAGE CAME OUVERTURE

Informations données à titre indicatif et sous réserve de modifications éventuelles

SERVOMOTEUR ELECTRIQUE RETOUR CONDENSATEUR TCR-N-KT

RECHERCHE DE PANNES

Défaut rencontré	Cause de défaut	Méthode de résolution
Servomoteur inactif	Réseau électrique non connecté.	Relier au réseau électrique.
	Tension incorrecte.	Vérifier la tension du servomoteur.
	Surchauffe du moteur.	Vérifier le couple du robinet.
	Raccordement défaillant.	Vérifier la connection au bornier.
	Condensateur démarrage endommagé.	Contacter le fournisseur pour réparation.
Pas de signal fin de course	Raccordement défaillant.	Vérifier les connections.
	Micro-rupteur endommagé.	Changer le micro-rupteur.
Robinet pas totalement fermé	Utilisation retour signal du contrôle servomoteur.	Recevoir un signal retour ne signifie pas que le servomoteur est complètement fermé, alors ne coupez pas l'alimentation.
	L'hystérésis augmente en raison de l'usure ou entre le servomoteur et l'axe du robinet.	Réajuster la came de fin de course. Contacter le fournisseur pour réparation.
Présence d'humidité ou d'eau dans le servomoteur	Section du câble utilisé non adaptée.	Contacter le fournisseur pour réparation.
	Raccordement câble non étanche.	
	Usure de joints d'étanchéité.	
	Vis de couvercle desserrées.	Sécher les parties internes et resserrer les vis du couvercle.

Informations données à titre indicatif et sous réserve de modifications éventuelles

