

1150-1153-LT10 BUTTERFLY VALVES WITH AP RE PNEUMATIC ACTUATOR

FEATURES

1150-1153-LT10 butterfly valves are intended for the automatic opening /closing of very diverse fluid pipes. The valve body is made of GS cast iron. The different configurations of the butterfly materials and of the liner make it suitable for many applications. Wafer mounting with centring ears between PN10/16 and ANSI 150 flanges. The ISO 5211 mounting pad allows the actuator to be directly assembled. The AP RE (adjustable stops) pneumatic motorisation is available in double and spring-return with numerous options.



Lloyd's Register
PED/2014/68/UE



Marine & Offshore
Division



LIMITS OF USE

Fluid pressure: PS	10 bar
Test pressure: PT	30 bar
Fluid temperature: WT	According to the table below
Ambient temperature	-15°C / +80°C
Motor compressed air	Mini 6 bar / maxi 10 bar



AVAILABLE MODELS

DN 32-40 to DN 300.

Connection between flanges PN10/16 and ANSI 150 RF.

Double and spring-return actuator.

Ref.	Butterfly	Liner	Example of applications	WT° min	WT° max
1150	316 SS / GS cast iron	EPDM	Cold water – warm water (110°C at peak) - ACS	-10°C	+110°C
1153	316 SS	EPDM	Demineralised water – alkalis (110°C at peak) - ACS	-10°C	+110°C

DIRECTIVES AND MANUFACTURING STANDARDS

OBJECT	Standard	ON	OBJECT	Standard
Pressure Equipment Directive 2014/68/EC	Cat. III modules B+C1	0094	Final test	ISO 5208
ATEX Directive	II 2G/D Tx zones 1,2,21 and 22	0038	Face-to-face dimension	ISO 5752 series 20
Flange dimension	EN 1092-1		Actuator pilot connection	NAMUR
Connection Motorisation	ISO 5211:		Switch box connection	VDI/VDE 3845
Sanitary conformity	ACS No. 07 ACC LY 504		Pneumatic actuator	EN 12517-3
SIL 3 level (Valve)	IEC 61508	TÜV	SIL 3 level (the actuator alone)	NKS 61508

Information given as an indication only, and subject to possible modifications



1150-1153-LT10 BUTTERFLY VALVES WITH AP RE PNEUMATIC ACTUATOR

CONSTRUCTION

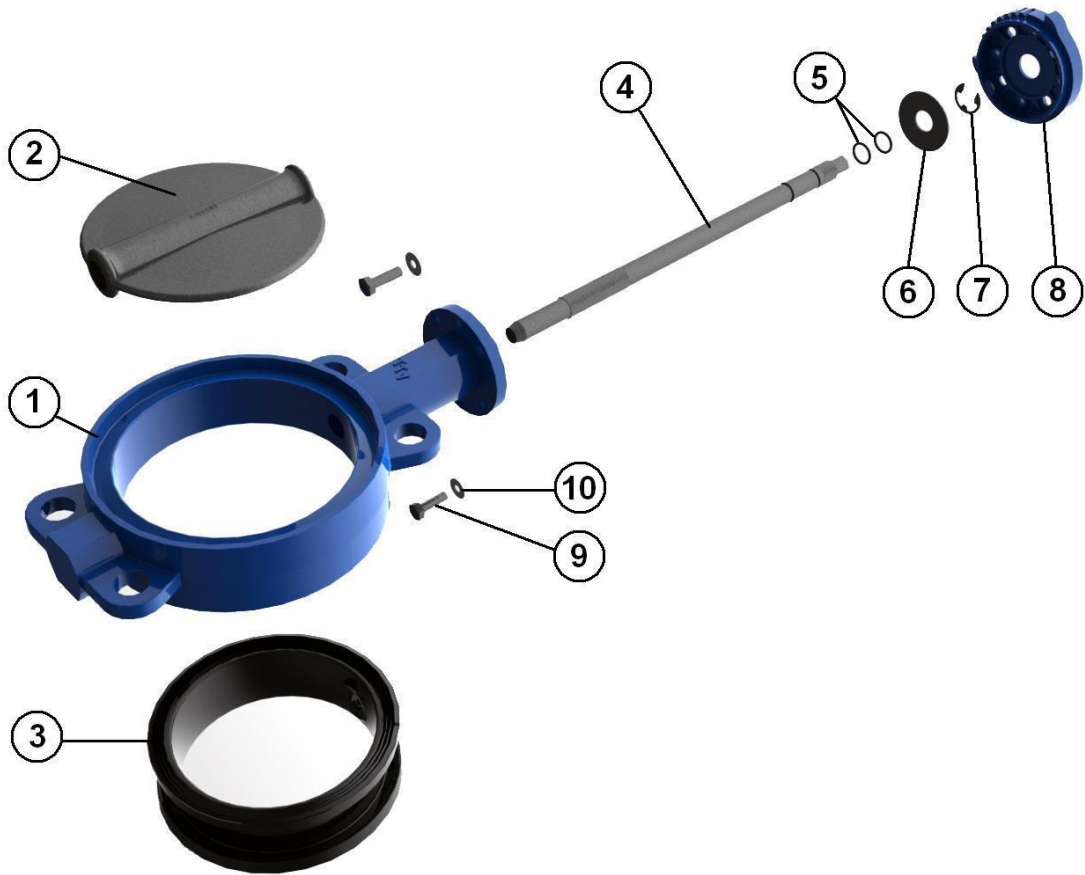

No°	Name	1150	1153
1	Body	GS EN GJS-500-7 cast iron	
2	Butterfly DN32-100	1.4408 SS	
3	Butterfly DN125-400	GS EN GJS-500-7 cast iron	1.4408 SS
3	Liner	EPDM	EPDM
4	Stem	420 SS	304 SS
5	O-ring	EPDM	EPDM
6	Ring	Steel	
7	Circlips	Steel	
8	ISO mounting pad	aluminium	
9	Screw	5.6 Steel	
10	Washer	Steel	

Information given as an indication only, and subject to possible modifications



1150-1153-LT10 BUTTERFLY VALVES WITH AP RE PNEUMATIC ACTUATOR

DIMENSIONS (mm)

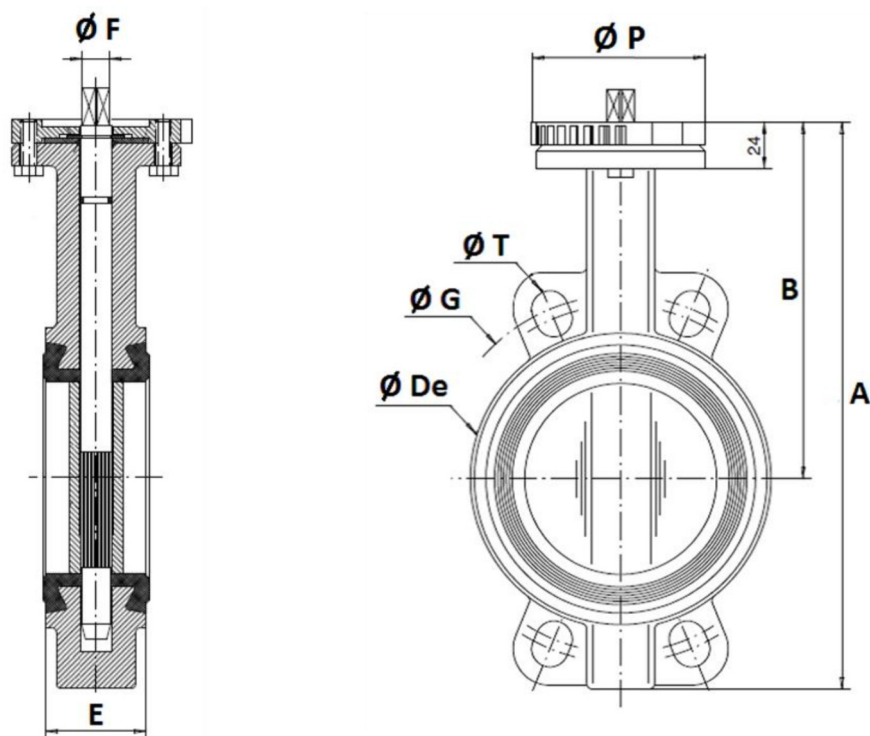

DN	32-40	50	65	80	100	125	150	200	250	300
A	206	228	248	265	298	331	349	430	461	524
B	140	156	161	169	187	206	215	255	248	280
Ø De	82	102	119	135	155	185	208	270	328	381
E	33	43	46	46	52	56	56	60	68	78
Ø F	9.5	9.5	12.5	14	14	17	17	21	23	26.5
Ø G	110	125	145	160	180	210	240	295	350	400
Ø P	88	88	88	88	88	105	105	105	150	150
Ø T	18	18	18	18	18	18	23	23	23	23
Weight (kg)	2,46	3,66	4,40	4,60	6	7,60	9,20	14,7	24,7	33

FLOW-RATE COEFFICIENT Kv (m³/h)

DN	32-40	50	65	80	100	125	150	200	250	300
Kv	70	109	200	334	551	901	1427	2383	3825	5659

Information given as an indication only, and subject to possible modifications

1150-1153-LT10 BUTTERFLY VALVES WITH AP RE PNEUMATIC ACTUATOR

AP RE PNEUMATIC MOTORISATION

The ALPHAIR RE motorisation proposed as standard comprises:

- rack and pinion actuator of anodised aluminium.
- a safety coefficient of 1.3 minimum compared to the nominal torque of the valve.
- air non-lubricated dry motor, minimum 6 bar pressure.
- an upstream / downstream pressure difference $\Delta P=10$ bar max.

The actuator assembly is of the following types:

- direct assembly with DN 32 to DN 200 aluminium motorisation mounting pad.
- yoke + stainless steel drive according to the EN 15081 standard for DN 250 to DN 300.

DN	Double-effect	V (litres)	Time (s)*	Spring-return	V (litres)	Time (s)*
32-40	RE 51	0.23	1	RES 64/6	0.45	1
50	RE 51	0.23	1	RES 64/6	0.45	1
65	RE 64	0.45	1	RES 76/6	0.61	1
80	RE 64	0.45	1	RES 76/6	0.61	1
100	RE 76	0.61	1	RES 86/6	0.98	2
125	RE 76	0.61	1	RES 101/6	1.80	2
150	RE 86	0.98	2	RES 116/6	2.80	2
200	RE 101	1.80	2	RES 126/6	3.70	3
250	RE 116	2.80	2	RES 146/6	4.90	3
300	RE 126	3.70	3	RES 181/6	11.1	5

For any other operating conditions, please contact us.

*indicative time of the no-load actuator for opening or closing.

INSTALLATION IN AN ATEX ZONE

For 1150-LT10+AP RE automatic valves to be installed in ATEX 1, 2, 21 or 22 zones, this has to be specified when ordering. Our services will check of the assembly, the installation of an earthing braid, and will issue an assembly certificate. Our authorised technicians carry out these operations in the workshop. Please contact us.

The special assembly and maintenance instructions for motorised valves in the ATEX zones must be followed.

MOTORISATION OPTIONS

1	actuators dimensioned for a compressed air pressure of 3, 4 or 5 bar
2	actuator dimensioned for an upstream / downstream pressure difference ΔP greater than 10 bar
3	actuator with special coatings, stainless steel actuator
4	Actuator for very low (-60°C) or very high ($+150^{\circ}\text{C}$) ambient temperatures.
5	manual override with declutchable gear box
6	compressed air filter regulator
7	All types of piloting solenoid valves
8	all types of switch boxes
9	all types of positioner
10	rapid exhaust, flow-rate limiters - exhaust brakes
OPTIONS ON THE VALVE	
1	Carbon steel body, 304 and 316 SS, bronze and aluminium
2	Carbon steel butterfly, 304 and 316 SS, copper-alu, Uranus, Hastelloy
3	Hypalon liner, silicone steam, white EPDM, natural rubber, neoprene, vulcanised
4	Stems of 420, 304, 316 SS, Hastelloy



Information given as an indication only, and subject to possible modifications



1150-1153-LT10 BUTTERFLY VALVES WITH AP RE PNEUMATIC ACTUATOR

114x, 115x AND 116x VALVES + AP ACTUATOR ASSEMBLY AND MAINTAINANCE INSTRUCTIONS

1 / CAUTION



1.1 - Cutting or crushing hazard

Never operate an automatic butterfly valve before its full assembly on the pipe installation. The accidental operation of the butterfly could lead to crushing or cutting of the operator's hand or arm.

1.2 - Burn hazard

114x, 115x and 116x +AP automatic valves can include a pilot-operated solenoid valve coil. The coil is intended to be permanently powered. In such a case, the coil could become very hot, hence you should not touch the coil to avoid a burn hazard.

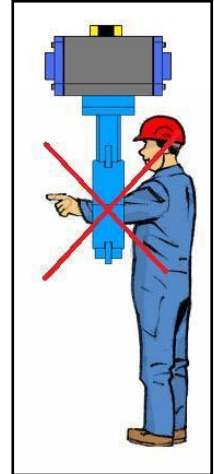

2 / CHECKS AT ACCEPTANCE

2.1 - order number check

The valve code is shown on the SECTORIEL label affixed on the actuator. Check that the code is identical with that shown on the delivery slip and the acknowledgement of receipt of your order.

2.2 - valve diameter check

The valve code is also shown on the SECTORIEL label affixed on the actuator. Check that the diameter matches that of your pipe installation.

2.3 - flange standard check

114x and 115x +AP valves have smooth lugs for mounting between PN10/16 flanges as per the EN 1092-1 standard and ANSI 150 as per the ANSI B16.5 standard. Check that the flanges of the pipe installation correspond to one of these standards.

The 1160-61-62-63-64 valves have internally threaded lugs. They are compatible with PN10/16 flanges up to DN150 and PN10 from DN200 to DN300 as per the EN 1092-1 standard. Check that the pipe installation is as per the standard.

2.4 - power supply voltage check

The power supply voltage of the pilot solenoid valve is shown on the coil. Check that the voltage matches that expected for the control of the automatic valve.

2.5 - compressed air supply pressure check

The supply pressure of the actuator is shown on the actuator's plate. Check that the compressed air network feeding the valve is indeed at this pressure. If need be, install a regulator filter upstream.

2.6 - fluid and ambient temperature parameter check

The pressure and temperature limits for the valve in service are shown in the table below. Check that, for your service, the pressure and temperature are compatible with the limits.

SECTORIEL 38290 - FRANCE	SERIAL NUMBER <input type="text"/>	VALVE <input type="text"/>
	CODE <input type="text"/>	DN <input type="text"/>
	ACTIO <input type="text"/>	MO <input type="text"/>
Read the mounting and servicing instructions carefully		

Information given as an indication only, and subject to possible modifications



1150-1153-LT10 BUTTERFLY VALVES WITH AP RE PNEUMATIC ACTUATOR

Fluid pressure: WP	16 bar up to DN 200 10 bar up to DN 400
Fluid temperature: WT	According to the table below
Ambient temperature	-15°C / +80°C
Motor compressed air	minimum 6 bar / maximum 10 bar

3 / STORAGE INSTRUCTIONS

Follow our "IMESTOCK" instructions for storage.

4 / ASSEMBLY INSTRUCTIONS

4.1 - Place of installation

The 114x, 115x and 116x +AP automatic valves can be installed both indoors and outdoors, while complying with the limit temperatures given in § 3.6.

If the valve is equipped with accessories (switch box, pilot solenoid valve), check their service temperatures and their IP code depending upon the place of installation.

4.2. - Connection to the pipe installation

4.2.1 - Mounting positions

The automatic valve has to be mounted either vertically or horizontal ly with an actuator, as shown in the diagram below:

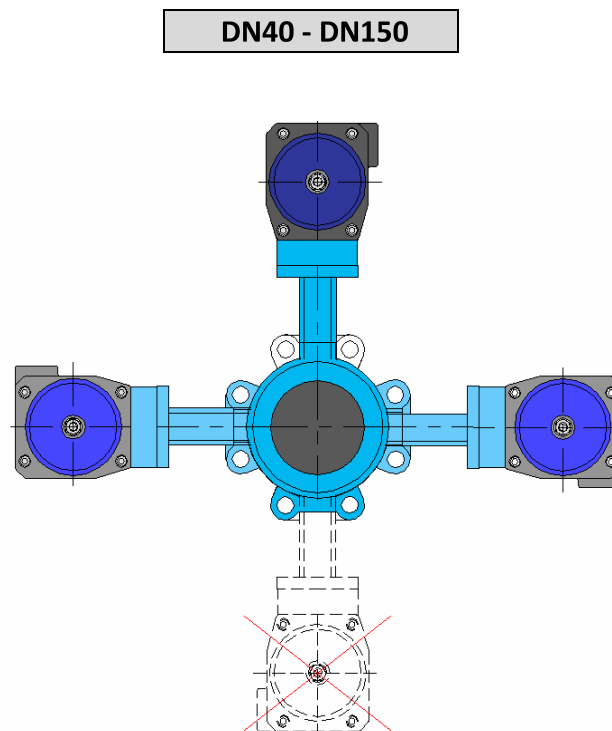

Information given as an indication only, and subject to possible modifications

1150-1153-LT10 BUTTERFLY VALVES WITH AP RE PNEUMATIC ACTUATOR

DN200 - DN400

Authorised with suitable support

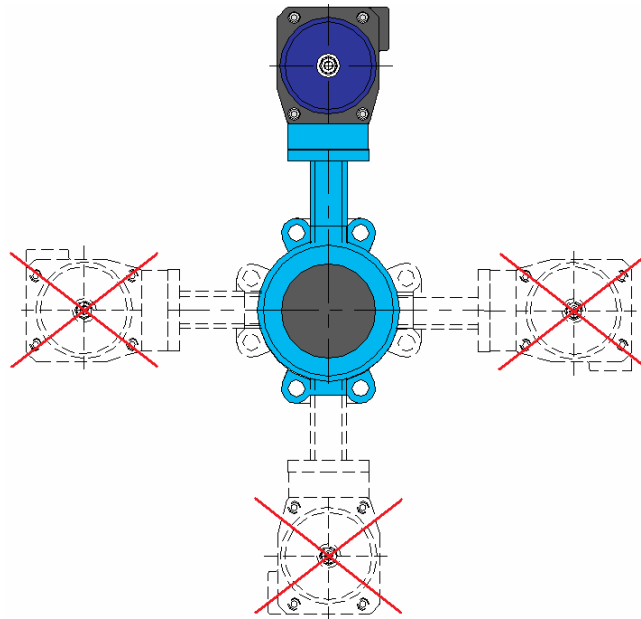

Authorised with suitable support

4.2.2 - Mounting at the end of a line

114x and 115x butterfly valves must not be installed at the end of a line. Only the 116x valves can be installed at the end of a line.

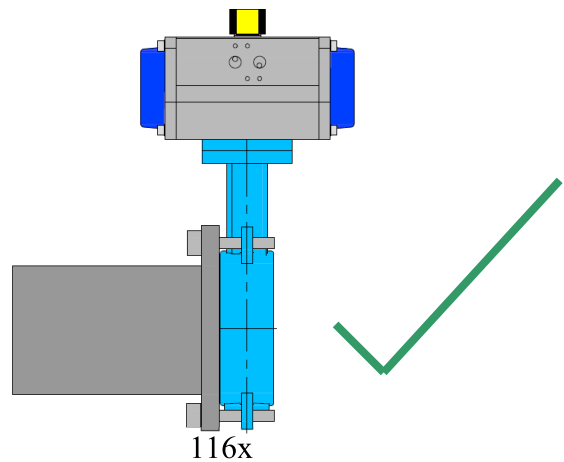
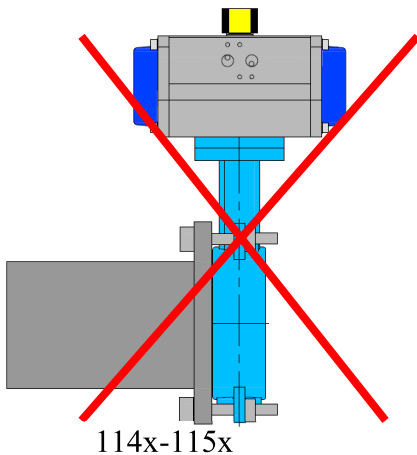

Possible blocking of the butterfly: protruding length.

At valve opening, the butterfly protrudes from the body according to the lengths shown in the table below.

DN	40	50	65	80	100	120	150	200	250	300	350	400
Protrusion (mm)	3,5	3,5	9,5	17	24	33,5	45,5	69	90	110,5	131	148

Information given as an indication only, and subject to possible modifications



1150-1153-LT10 BUTTERFLY VALVES WITH AP RE PNEUMATIC ACTUATOR

You must take it into account at mounting and not abut another valve element immediately upstream and downstream which could block the movement of the butterfly (e. g. a swing valve).

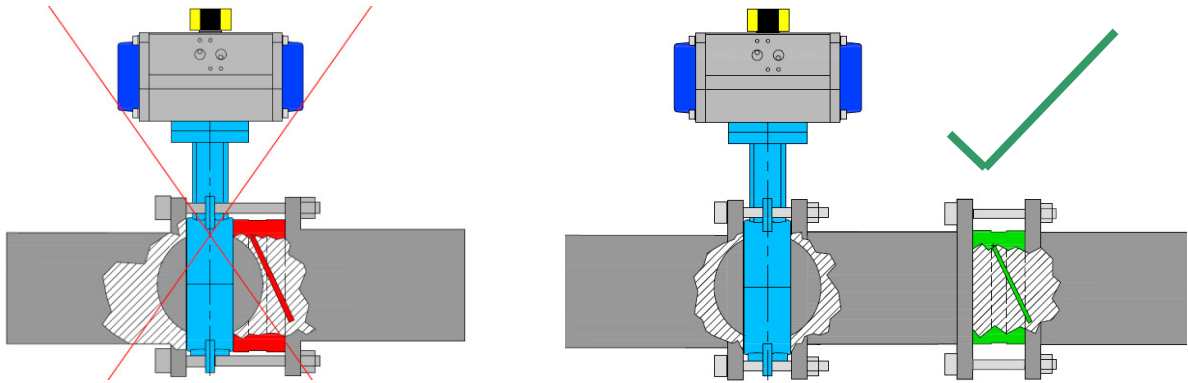

4.2.3 - Mounting precautions:

Before any intervention on the valve, please follow the following indications:

Before installing the valve, clean the piping (brazing residues, metal swarf, sealing material, etc.).

Isolate the pipe installation upstream and downstream.

Bleed the pipe installation in order to bring it to ambient temperature and pressure.

Do not force the piping to align it so as to prevent applying stress on the valve body.

Wear the safety equipment required for this type intervention (gloves and goggles).

4.2.4 - Valve installation on the piping

For all asymmetrical devices, check their orientation with regard to the normal direction of flow, and you must mount them in their operating position.

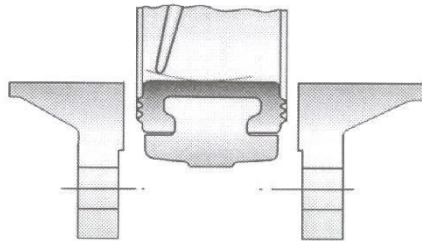

The gap in-between flanges has to be large enough to allow the valve be inserted without the elastic liner getting caught. The butterfly has to be in an almost closed position.

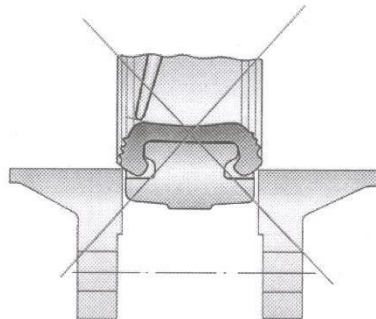

The liner can get damaged if the counter-flanges are not sufficiently spaced.

Information given as an indication only, and subject to possible modifications

1150-1153-LT10 BUTTERFLY VALVES WITH AP RE PNEUMATIC ACTUATOR

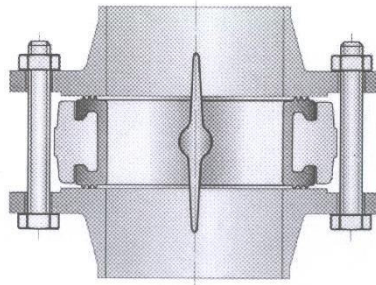

The butterfly has to be in the fully open position after positioning the valve in-between the counter-flanges and before tightening the bolts, otherwise the elastic liner might be deformed or deteriorated during the tightening of the first manoeuvre.

4.2.5 - Installation of the double acting AP version

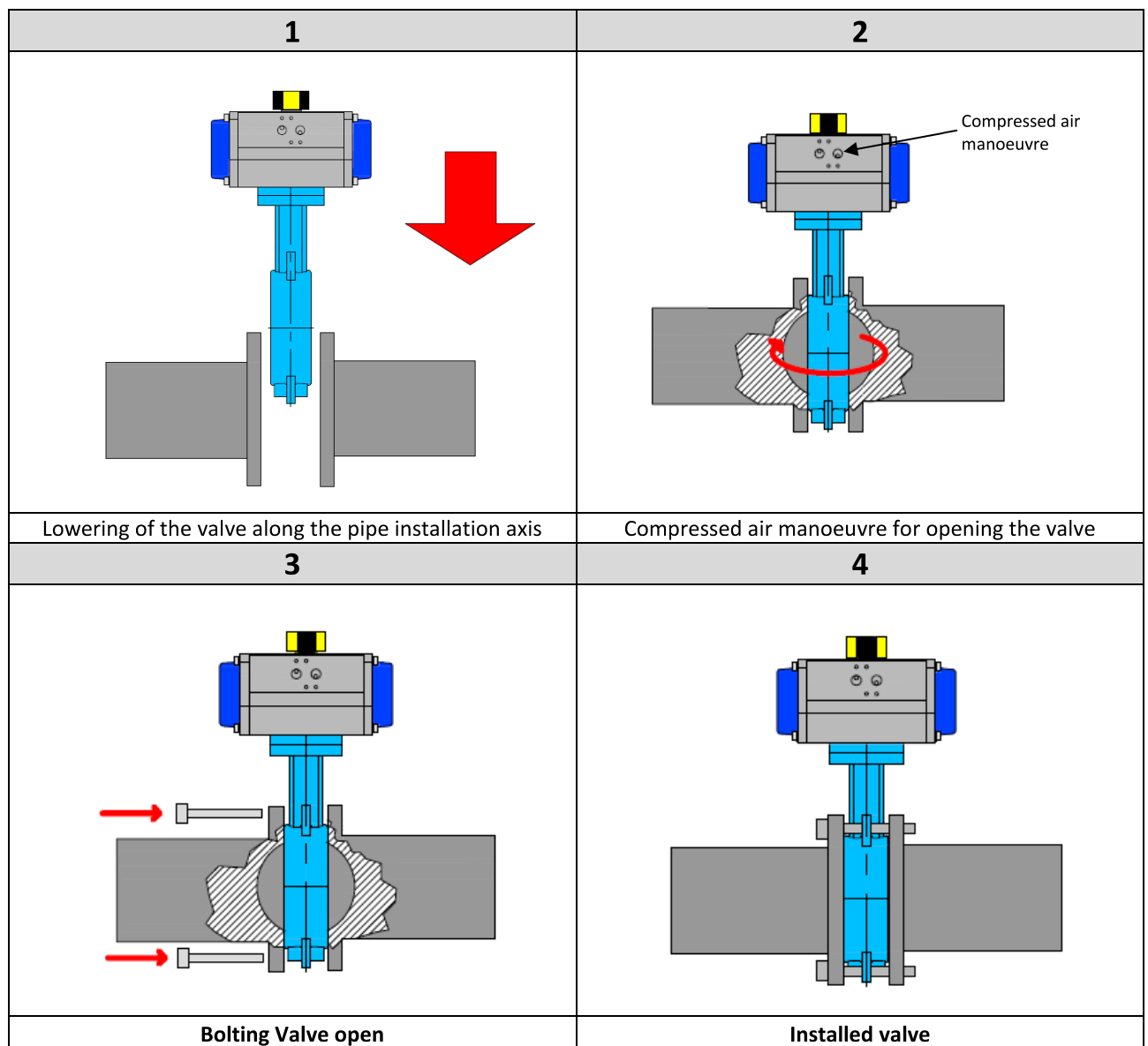

Information given as an indication only, and subject to possible modifications

1150-1153-LT10 BUTTERFLY VALVES WITH AP RE PNEUMATIC ACTUATOR

4.2.6 - Installation of the single acting NC (normally closed) AP version

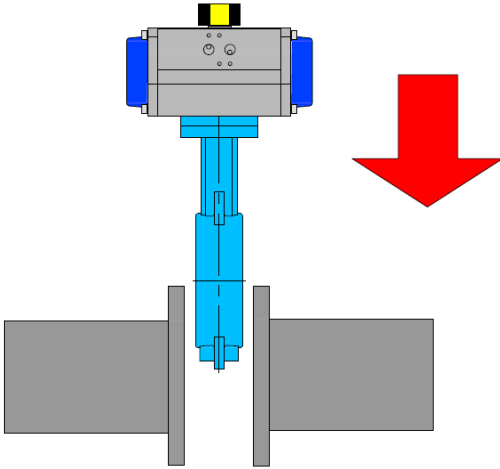
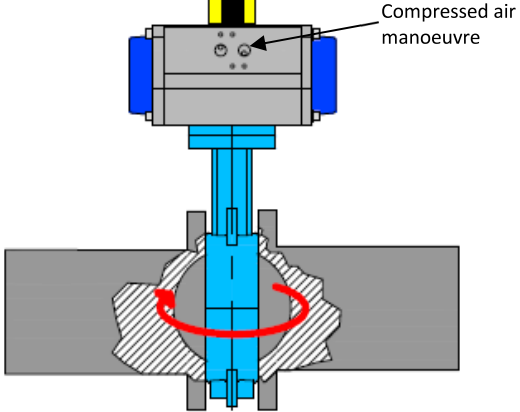
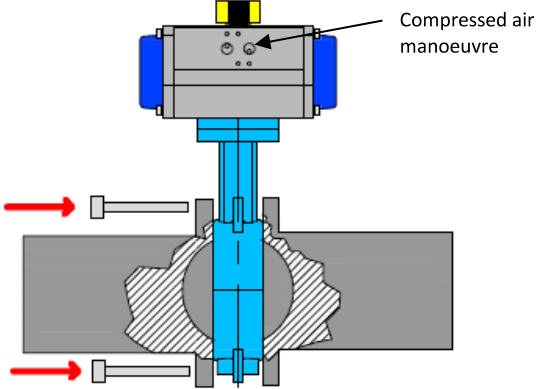
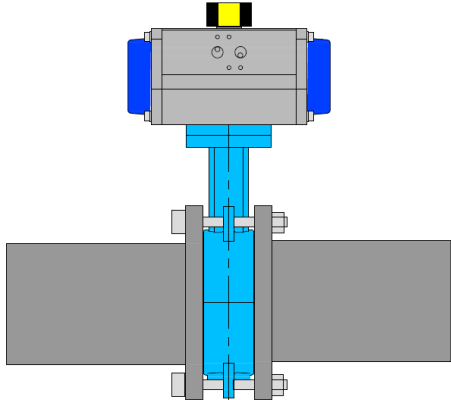
1	2
	
Lowering of the valve along the pipe installation axis.	Compressed air manoeuvre throughout the installation, for opening the valve. Indeed, if the air supply is cut-off, the valve will be closed by the return of the actuator's spring.
3	4
	
Bolting Open valve	Installed valve

Information given as an indication only, and subject to possible modifications

1150-1153-LT10 BUTTERFLY VALVES WITH AP RE PNEUMATIC ACTUATOR

4.2.7 – Installation of the single acting NO (normally open) AP version

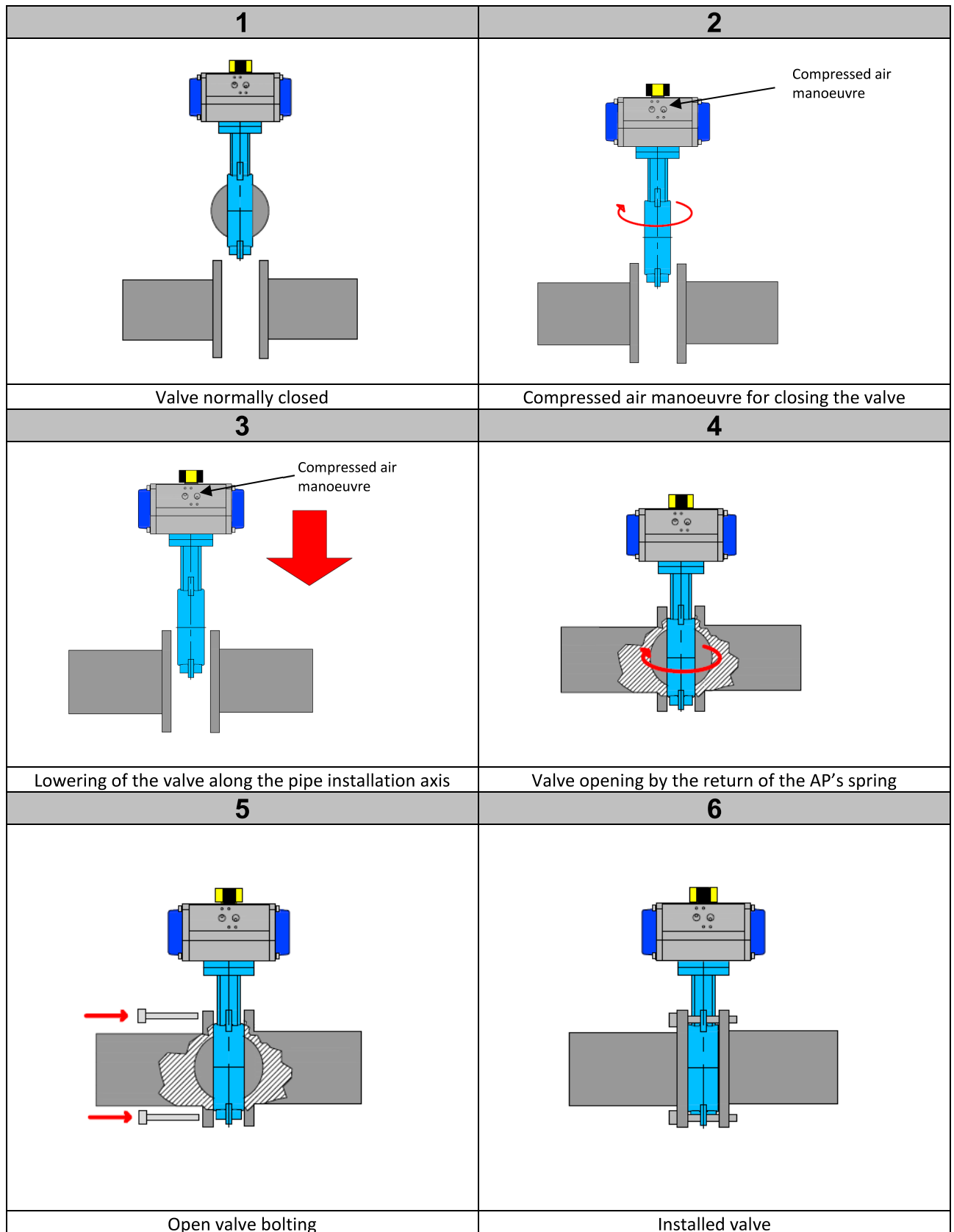

Information given as an indication only, and subject to possible modifications

1150-1153-LT10 BUTTERFLY VALVES WITH AP RE PNEUMATIC ACTUATOR

4.2.8 - connection to the pipe installation

Nuts and bolts for PN10/16 114x and smooth lug 115x

DN	ØD		ØK		Hole number		Nuts and bolts	
	PN10	PN16	PN10	PN16	PN10	PN16	PN10	PN16
40	150		110		4		M16x90	
50	165		125		4		M16x100	
65	185		145		4		M16x110	
80	200		160		8		M16x110	
100	220		180		8		M16x120	
125	250		210		8		M16x130	
150	285		240		8		M20x140	
200	340		295		8	12	M20x140	
250	395	405	350	355	12	12	M20x160	M24x
300	445	460	400	410	12	12	M20x160	M24x
350	505	520	460	470	16	16	M20x170	\
400	565	580	515	525	16	16	M24x200	\

Nuts and bolts for PN10/16 116x and threaded lug 118x

DN	ØD		ØK		Hole number		Nuts and bolts	
	PN10	PN16	PN10	PN16	PN10	PN16	PN10	PN16
40	150		110		4		Zinc-plated M16x30 steel screw	
50	165		125		4		VAZ M16x35	
65	185		145		4		VAZ M16x35	
80	200		160		8		VAZ M16x40	
100	220		180		8		VAZ M16x40	
125	250		210		8		VAZ M16x45	
150	285		240		8		VAZ M20x45	
200	340		295		8	12	VAZ M20x45	
250	395	405	350	355	12	12	VAZ 20x45	VAZ 24x
300	445	460	400	410	12	12	VAZ 20x60	VAZ 24x
350	505	520	460	470	16	16	VAZ 20x	\
400	565	580	515	525	16	16	VAZ 24x	\

4.3 - connection to the compressed air supply network

The compressed air connection is performed through the port 1 – G 1/4'' threaded – of the pilot solenoid valve. Exhausts 3 and 5 - G 1/8'' threaded - are factory equipped with silencer filters.

Information given as an indication only, and subject to possible modifications



1150-1153-LT10 BUTTERFLY VALVES WITH AP RE PNEUMATIC ACTUATOR

4.4 - pilot solenoid valve connection to the electrical control network

The electrical connection shall be performed by qualified personnel, as per the standards in vigour.

Depending upon the supply voltage, the components have to earthed as per the standards and local regulations in vigour.

The coil must be wired with the power off.

Remove the coil of the pilot solenoid valve by unscrewing the upper nut.

Slip the cable through the cable clamp and the associated cable gland (M20x1.5)

Connect the cable wires to the coil terminals and to the earth crimp connector. When the coil is well centred, tighten the cable gland and the cable holding jaws.

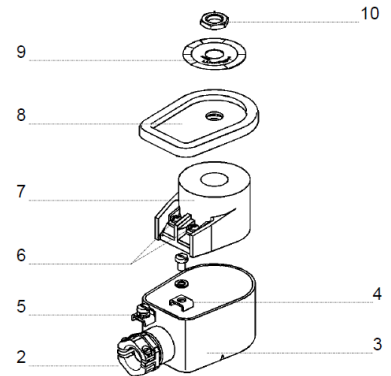

4.5 - switch box connection to the electrical control network

The electrical connection shall be performed by qualified personnel, as per the standards in vigour.

Depending on the supply voltage, the components



4.6 - operating test

Perform an operating test as follows after having made the pneumatic and electrical connections:

A / opening test

- power the coil of the pilot solenoid valve,

- visually check that the valve is open: the switch box indicator must show the OPEN position,

b / closing test

- turn off the power supply to the coil of the pilot solenoid valve,

- visually check that the valve closes instantaneously: the switch box indicator must show the CLOSED position.

5 / MAINTENANCE INSTRUCTIONS

5.1 - Before any intervention

5.1.1 - Depressurize, drain and bring to ambient temperature, the pipe installation on which the valve is mounted.

5.1.2 - Close the compressed air supply to the actuator and depressurize the actuator. The valve will then close automatically.

5.1.3 - Turn off the electrical supply to the pilot solenoid valve.

5.1.4 - Wear suitable protective equipment.

5.1.5 - Provide means of lifting and support appropriate for the maintenance operation.

Information given as an indication only, and subject to possible modifications



1150-1153-LT10 BUTTERFLY VALVES WITH AP RE PNEUMATIC ACTUATOR

Maintenance:

The absence of leak at the liner and at the valve stem should be regularly checked. If a leak occurs at the stem, replace the o-ring, if it occurs at the liner, the liner has to be replaced.

Important: All maintenance and servicing operations must be performed under the best safety conditions. Before any intervention, the valve has to be removed taking the above-mentioned precautions which apply both to mounting and removal.

Worn part replacement:

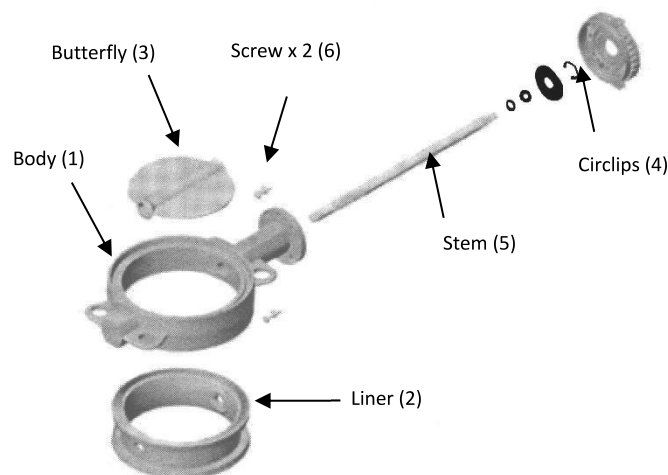

Remove the motor actuator. Unscrew the screws (6), remove the circlips (4). This frees the shaft (5), thus enabling the liner (2) and the butterfly (3) to be taken out of the body (1). Replace the worn parts: To obtain the list of spare parts for every valve, please contact our technical department at: +33 (0)474 94 90 70

5.2 - Valve maintenance

In the event of a leak on the line, check the state of the butterfly (1) and of the liner (4). If need be, replace them.

Codes of spare parts:

DN	Liner					Butterfly		Stem
	EPDM	EPDM C	NBR	SILICONE	FKM	cast iron	Stainless steel	
40	985946	985966	985986		986026	9865030	9865020	9865040
50	985947	985967	985987	986007	986027	9865031	9865021	9865041
65	985948	985968	985988	986008	986028	9865032	9865022	9865042
80	985949	985969	985989	986009	986029	9865033	9865023	9865043
100	985950	985970	985990	986010	986030	9865034	9865024	9865044
125	985951	985971	985991	986011	986031	9865035	9865025	9865045
150	985952	985972	985992	986012	986032	9865036	9865026	9865046
200	985953	985973	985993	986013	986033	9865037	9865027	9865047
250	985954	985974	985994	986014	986034	9865038	9865028	9865048
300	985955					9865039	9865029	9865049

In the event of a leak at the stem, check the state of the o-rings of the stem.

Information given as an indication only, and subject to possible modifications



1150-1153-LT10 BUTTERFLY VALVES WITH AP RE PNEUMATIC ACTUATOR

5.3 - Actuator maintenance

Refer to the actuator's IME.

6 / HELP TO TROUBLESHOOTING

The valve stays in the closed position	Check the electrical power supply to the pilot solenoid valve
	Check the state of the coil of the pilot solenoid valve
	Check the compressed air supply
	Check the actuator's sealing
The valve stays in the open position	Check the absence of power supply to the pilot solenoid valve
	Check the absence of foreign bodies inside the slides of the pilot solenoid valve
No fluid flows in the open position	Check for clogging of the filter
	Check the upstream pressure on the pipe installation
Leak on the line when the valve is in position	Check the state of the valve seats.
Leak at the valve packing gland	Check the state of gaskets of the packing gland

7 / INSTRUCTION ON OUR PRODUCT DISPOSAL AND RECYCLING

Our valve does not contain any hazardous substance. At the valve end of life, after removing the equipment, the user's obligation is to call a scrap metal collector who will sort and recycle the different parts of the equipment. For your information, the following families of metal are present in our product: steel, stainless steel and aluminium.

With regard to the electrical parts of the equipment, they have to be separated from the rest of the valve and given to a company specialised in recycling waste from electrical and electronic equipment, as per the directive 2002/96/EC.



Information given as an indication only, and subject to possible modifications



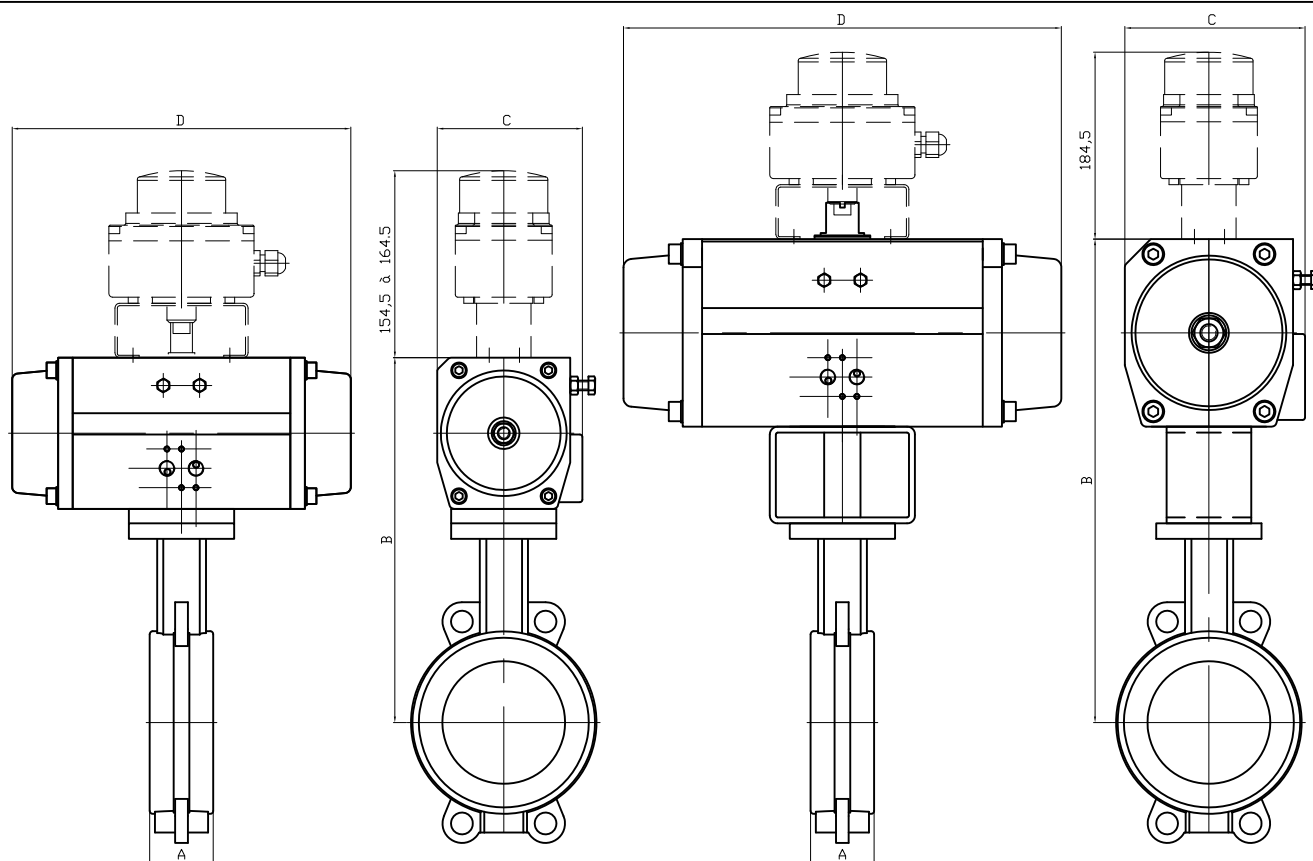

* : montage avec platine H=80mm

DN	32-40		50		65		80		100		125	
ALPHAIR	51 RE	64 RES	51 RE	64 RES	64 RE	76 RES	64 RE	76 RES	76 RE	86 RES	76 RE	101RES
A	33		43		46		46		52		56	
B	209	226	225	242	247	263	255	271	289	299	308	333
C	75	86	75	86	86	94	86	94	94	104	94	120
D	138	155	138	155	155	203	155	203	203	239	203	261
KG	3.7	4.4	4.9	5.6	6.1	7.7	6.3	7.9	8.9	10.7	10.5	14.3

DN	150		200		250		300		350		400	
ALPHAIR	86 RE	116RES	101 RE	126RES	116 RE	146RES	126 RE	181RES	161 RE	201RES	201 RE	271RES
A	56		60		68		78		78		102	
B	327	361	382	413	394	425	438	580*	576*	520	560	752*
C	104	134	120	145	134	165	145	204	182	222	222	352
D	239	304	261	333	304	398	333	482	424	528	528	684
KG	13.3	19.2	20.5	27.6	33.3	41.3	44.1	56.8	58.7	84.7	88.8	165