

CARBON STEEL DOUBLE OFFSET WAFER BUTTERFLY VALVE PN16/25 FIRE SAFE

Carbon steel double offset butterfly valve wafer for steam, heating, geothermics, industrial cold, shipbuilding and petrochemical.

PTFE filled with 15% graphite packing and seat for a temperature up to +210°C.

Valve with firesafe certificate ISO 10497 to reduce risks in case of fire.

Compatible with explosive atmosphere, ATEX Zone 1&21 and Zone 2&22.

Handle up to DN150, gearbox over.

Thanks to the ISO 5211 plate, an actuator can be installed directly on the valve.



Size : DN50 to DN600

Connection : Between flanges PN25 or PN16

Min Temperature : -29°C

Max Temperature : +210°C

Max Pressure : 25 Bars

Specifications : Full crossing stem
ISO 5211 mounting pad
Wafer type

Materials : Carbon steel ASTM A216 WCB

CARBON STEEL DOUBLE OFFSET WAFER BUTTERFLY VALVE PN16/25 FIRE SAFE

SPECIFICATIONS :

- 100% tightness
- Wafer type
- Between PN25 or PN16 flanges
- Double offset
- Bidirectional with preferential flow direction indicated by the arrow
- Fire safe according to ISO 10497 : 2010
- ISO 5211 mounting pad
- Stainless steel CF8M disc
- Full crossing stem
- 10 positions ductile iron handle, with locking device up to DN150
- Gear box from DN 200 to DN600
- Inorganic zinc rich primer, gray color, 10 µm thickness
- Finish painting heat resisting aluminum Silver color RAL 1504, 30 µm thickness
- Ductile iron EN GJS-400-15 handle with silver painting RAL 9006 color

USE :

- Heating, geothermics, industrial cold, shipbuilding, petrochemical
- Steam : 10 bars maximum
- Min and max Temperature Ts : - 29°C to + 210°C
- Max Pressure Ps : 25 bars (see graph)
- Vacuum : 10⁻³ torr
- When using at dead end of pipeline, reverse preferential flow direction

RANGE :

- Wafer type with carbon steel body , and handle **Ref. 1113** DN 50 to DN 150
- Wafer type with carbon steel body , and gear box **Ref. 1113** DN 200 to DN 600
- Gear box **Ref. 1193** from DN 50 to DN 350

CONNECTION :

- Between PN25 or PN16 flanges

PRESSURE / TEMPERATURE GRAPH :

PRESSURE

(Bar)

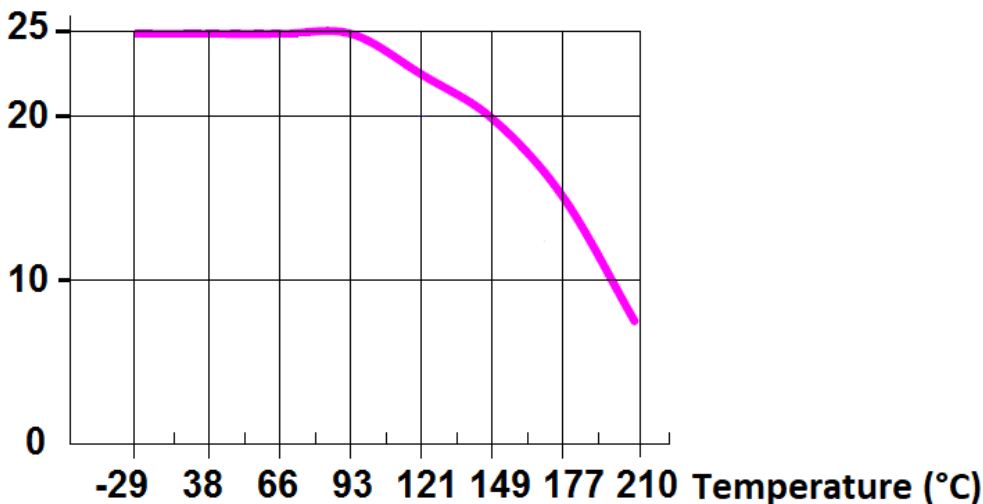

CARBON STEEL DOUBLE OFFSET WAFER BUTTERFLY VALVE PN16/25 FIRE SAFE

TORQUE VALUE (in Nm with safety coefficient of 30 % included) :

DN	50	65	80	100	125	150	200	250	300	350	400	450	500	600
Torque (Nm) at 0 Bar	29	37	50	76	118	147	176	255	333	461	657	843	1078	1274
Torque (Nm) at 5 Bar	32	46	61	88	137	196	235	323	470	725	960	1058	1382	1617
Torque (Nm) at 10 Bar	39	61	76	103	170	225	294	421	549	833	1264	1362	1803	2225
Torque (Nm) at 15 Bar	43	69	92	118	194	265	353	480	686	990	1509	1705	2166	2783
Torque (Nm) at 20 Bar	49	83	107	140	223	294	421	568	862	1196	1686	2087	2920	3783
Torque (Nm) at 25 Bar	59	97	127	162	242	333	480	647	1009	1421	1882	2646	3410	4704

MAX TORQUE MAST (in Nm) :

DN	50	65	80	100	125	150	200	250	300	350	400	450	500	600
MAST	163	324	647	906	1295	2589	5179	10357						

FLOW COEFFICIENT Kv (m3 / h) :

DN	Percent of Rated Travel									
	10%	20%	30%	40%	50%	60%	70%	80%	90%	100%
50	3,5	11,2	22,5	33,7	62,3	109,0	132,3	176,4	201,5	138,4
65	6,1	19,9	38,9	57,1	105,5	185,1	223,1	298,4	339,9	224,0
80	8,6	29,4	58,8	87,4	160,0	280,2	338,2	452,3	515,5	344,2
100	9,5	35,5	62,3	95,1	185,1	324,3	359,8	467,9	497,3	530,2
125	14,7	45,8	91,7	135,8	250,8	437,6	528,4	705,7	805,2	847,6
150	20,8	66,6	131,5	195,5	360,7	629,6	761,1	1017,1	1158,9	1189,2
200	36,3	118,5	234,4	347,7	472,2	661,6	851,0	1126,9	1254,1	1513,5
250	108,1	263,8	425,5	504,2	798,3	1089,7	1427,1	1781,7	2110,3	2306,6
300	147,0	358,9	578,6	834,6	1124,3	1517,9	2645,7	2987,3	3328,9	3776,1
350	192,0	437,6	688,4	1007,6	1395,9	1938,2	2700,2	3658,4	4635,8	5158,1
400	272,4	464,4	780,1	1145,1	1646,7	2149,2	3202,7	4666,0	5956,4	6713,2
450	339,0	818,2	1259,3	1764,4	2435,5	3388,6	4684,2	6106,9	7381,8	8090,1
500	443,7	1035,3	1586,2	2212,4	3031,4	4275,1	6216,8	7867,8	9523,2	10226,3
600	730,8	1609,5	2380,1	3382,5	4757,7	6628,4	9375,3	12475,0	15868,0	17178,2

CARBON STEEL DOUBLE OFFSET WAFER BUTTERFLY VALVE PN16/25 FIRE SAFE

MATERIALS VALVES :

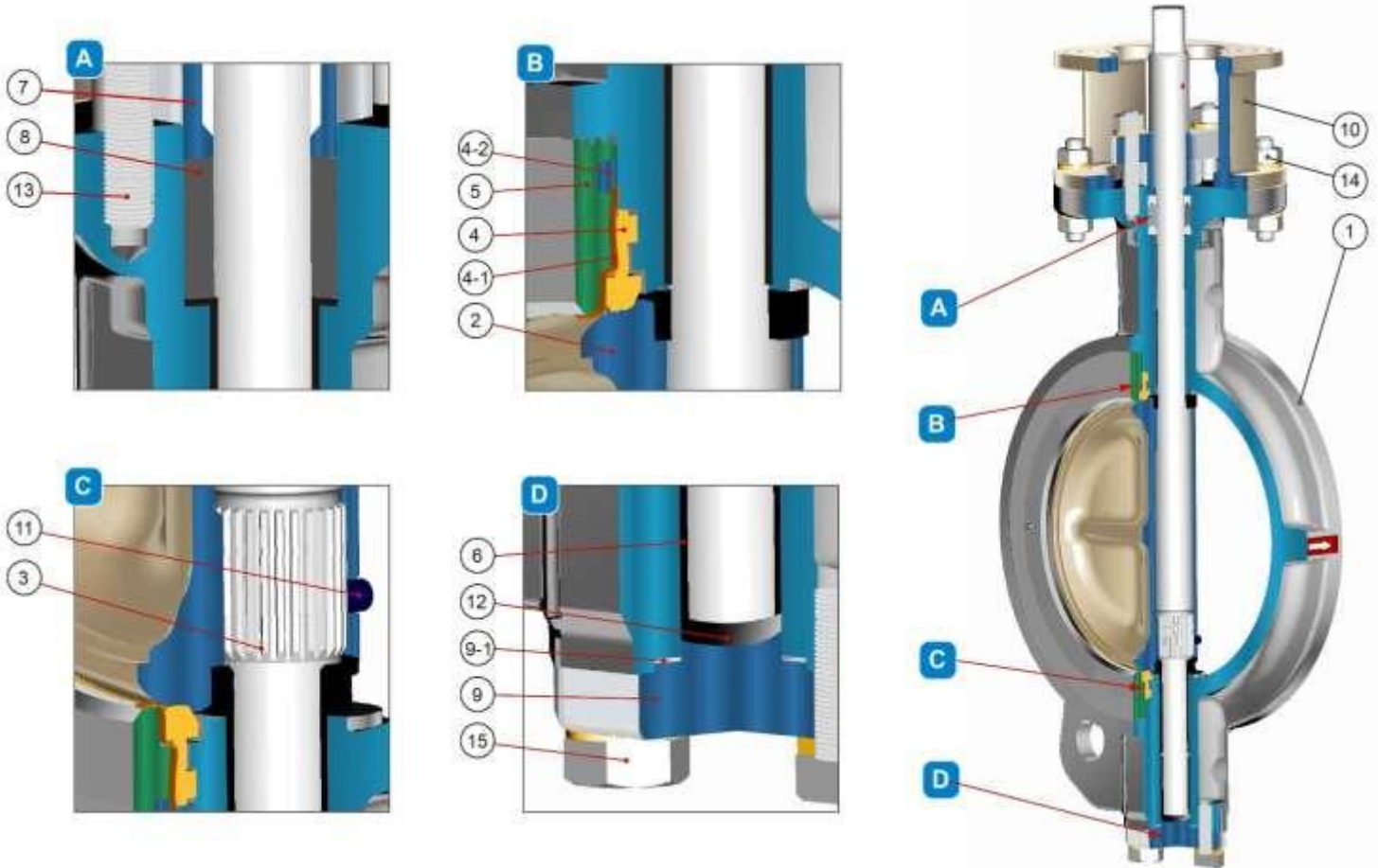

(* : Included in gaskets kit)

Item	Designation	Materials
1	Body	ASTM A216 WCB
2	Disc	ASTM A351 CF8M
3	Shaft	ASTM A564 630
4*	Seat	PTFE filled with 15% graphite
4-1	Metal seat	Inconel 718
4-2*	Gasket	Graphite
5	Retainer	ASTM A351 CF8
6*	Bushing	PTFE + AISI 316
7	Gland	ASTM A351 CF8
8*	Gland packing	Graphite
9	Bottom cover	ASTM A216 WCB
9-1*	Bottom cover gasket	Graphite
10	Yoke	ASTM A216 WCB
11*	Stop stud	ASTM A193 Gr. B8M
12*	Lock plate	PTFE filled with 15% graphite + AISI 316
13	Stud	ASTM A193 Gr. B8
14	Nut	ASTM A194 Gr. 8
15	Bolt	ASTM A193 Gr. B8

Repairability :

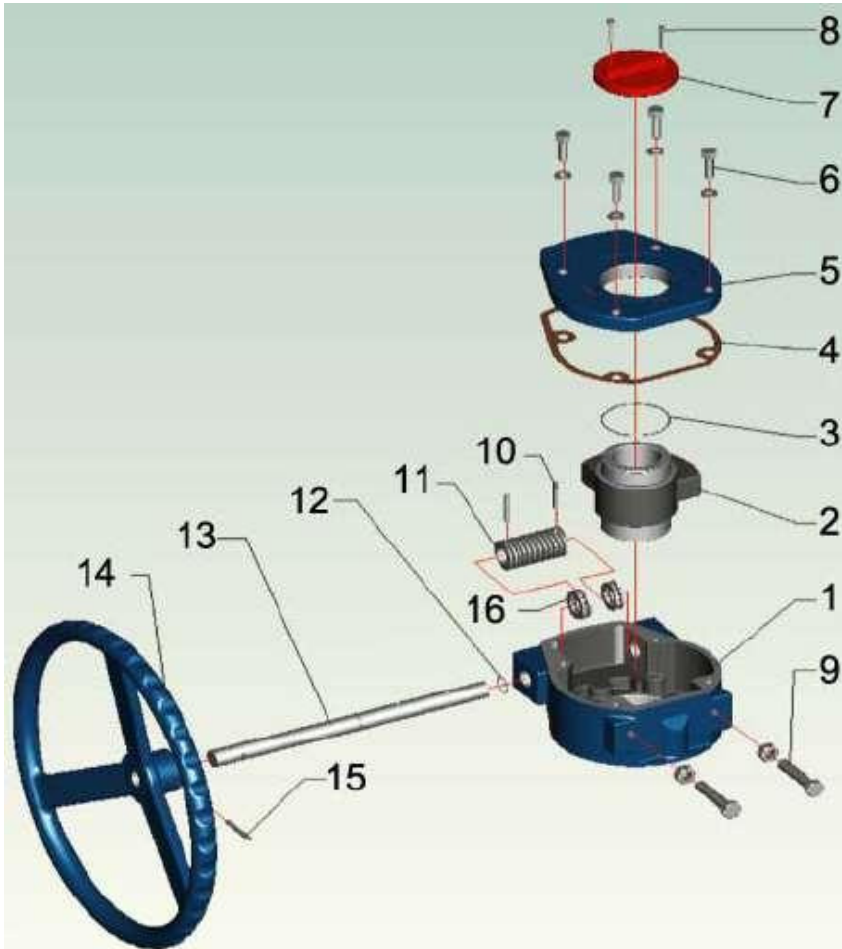

*Gaskets Kit (Item 4, 4-2, 6, 8, 9-1, 11 et 12)	
DN50	9865290
DN65	9865291
DN80	9865292
DN100	9865293
DN125	9865294
DN150	9865295
DN200	9865296
DN250	9865297
DN300	9865298
DN350	9865299

CARBON STEEL DOUBLE OFFSET WAFER BUTTERFLY VALVE PN16/25 FIRE SAFE
MATERIALS GEARBOX DN50 - 350 :

Item	Designation	Materials
1	Body	Cast iron EN GJL
2	Worm gear	Ductile iron EN GJS
3	O ring	NBR
4	Gasket	Paper
5	Cover	Cast iron
6	Screw	Steel
7	Indicator	Cast iron
8	Screw	Steel
9	Stop bolt	Steel
10	Pin	Steel
11	Worm	Steel
12	O ring	NBR
13	Worm shaft	Steel
14	Handwheel	Cast iron
15	Pin	Steel
16	Bearing	Steel

CARBON STEEL DOUBLE OFFSET WAFER BUTTERFLY VALVE PN16/25 FIRE SAFE

MATERIALS GEARBOX DN400 - 500 :

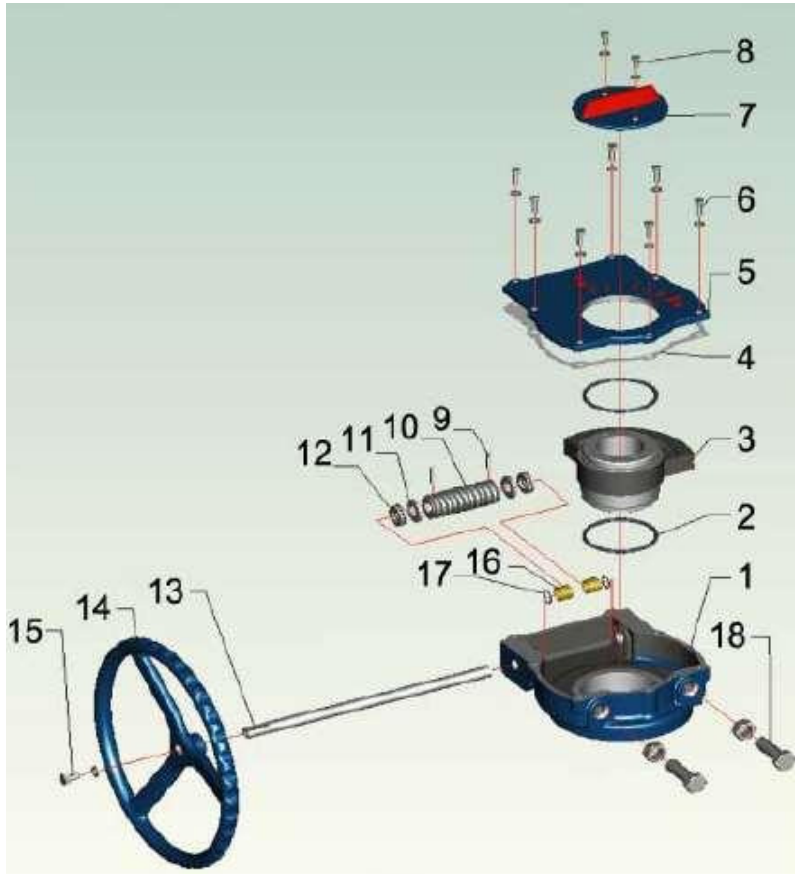

Item	Designation	Materials
1	Body	Cast iron
2	O ring	NBR
3	Worm gear	Ductile iron
4	Gasket	Paper
5	Cover	Cast iron
6	Screw	Steel
7	Indicator	Cast iron
8	Screw	Steel
9	Pin	Steel
10	Worm	Steel
11	Ring	Steel
12	Bearing	Steel
13	Worm shaft	Steel
14	Handwheel	Cast iron
15	Screw	Steel
16	Bushing	Copper
17	O ring	NBR
18	Stop bolt	Steel

CARBON STEEL DOUBLE OFFSET WAFER BUTTERFLY VALVE PN16/25 FIRE SAFE

MATERIALS GEARBOX DN600 :

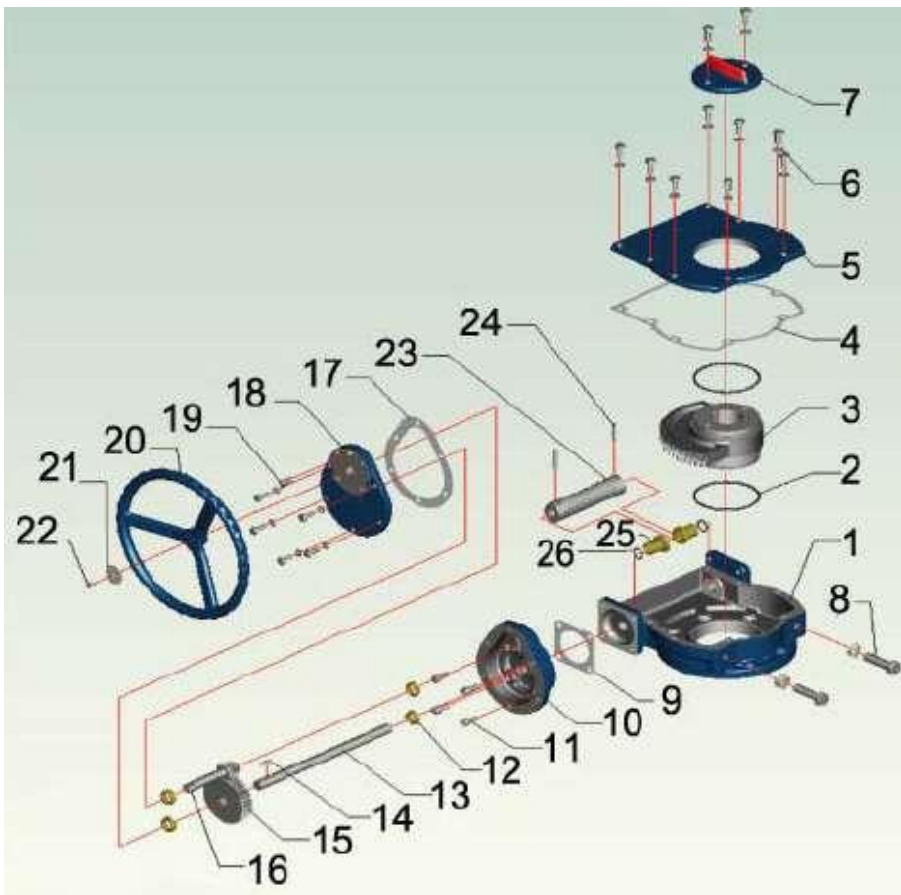

Item	Designation	Materials
1	Body	Cast iron
2	O ring	NBR
3	Worm gear	Ductile iron
4	Gasket	Paper
5	Cover	Cast iron
6	Screw	Steel
7	Indicator	Cast iron
8	Stop bolt	Steel
9	Gasket	Paper
10	Spur gear body	Cast iron
11	Screw	Steel
12	Bearing	Steel
13	Worm shaft	Steel
14	Key	Steel
15	Spur gear	Steel
16	Spur gear shaft	Steel
17	Gasket	Paper
18	Cover	Cast iron
19	Screw	Steel
20	Handwheel	Cast iron
21	Washer	Steel
22	Screw	Steel
23	Worm	Steel
24	Pin	Steel
25	Bushing	Copper
26	O ring	NBR

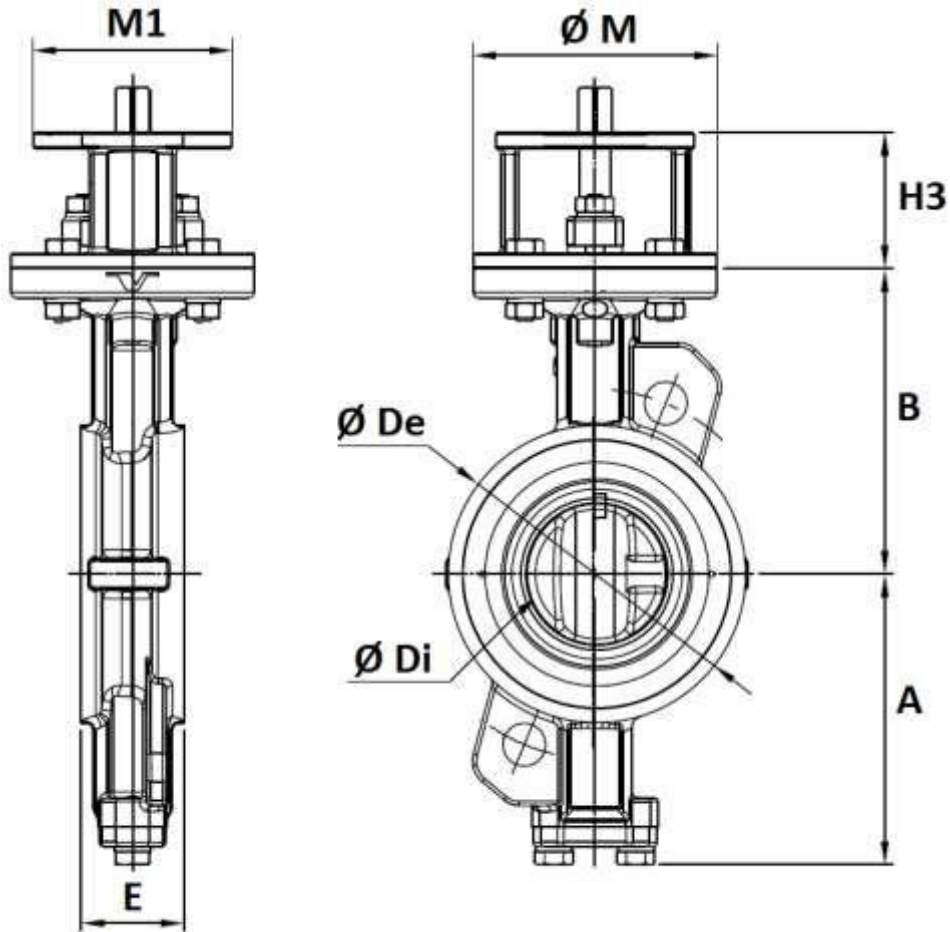
CARBON STEEL DOUBLE OFFSET WAFER BUTTERFLY VALVE PN16/25 FIRE SAFE
VALVE SIZE DN50 - 150 (in mm) :

DN	50	65	80	100	125	150
E	43	46	47	53	57	56
A	99	110	128	150	163	176
B	118	125	140	157	170	185
H3	60	60	70	70	70	70
Ø M	90	90	125	125	125	125
M1	70	70	102	102	102	102
Ø De	92	108	126	153	184	212
Ø Di	37	63	78	95	118	143
Min pipe diameter	49	62	78	93	120	149
Weight (in Kg)	3.9	4.5	7	9	12	13.5

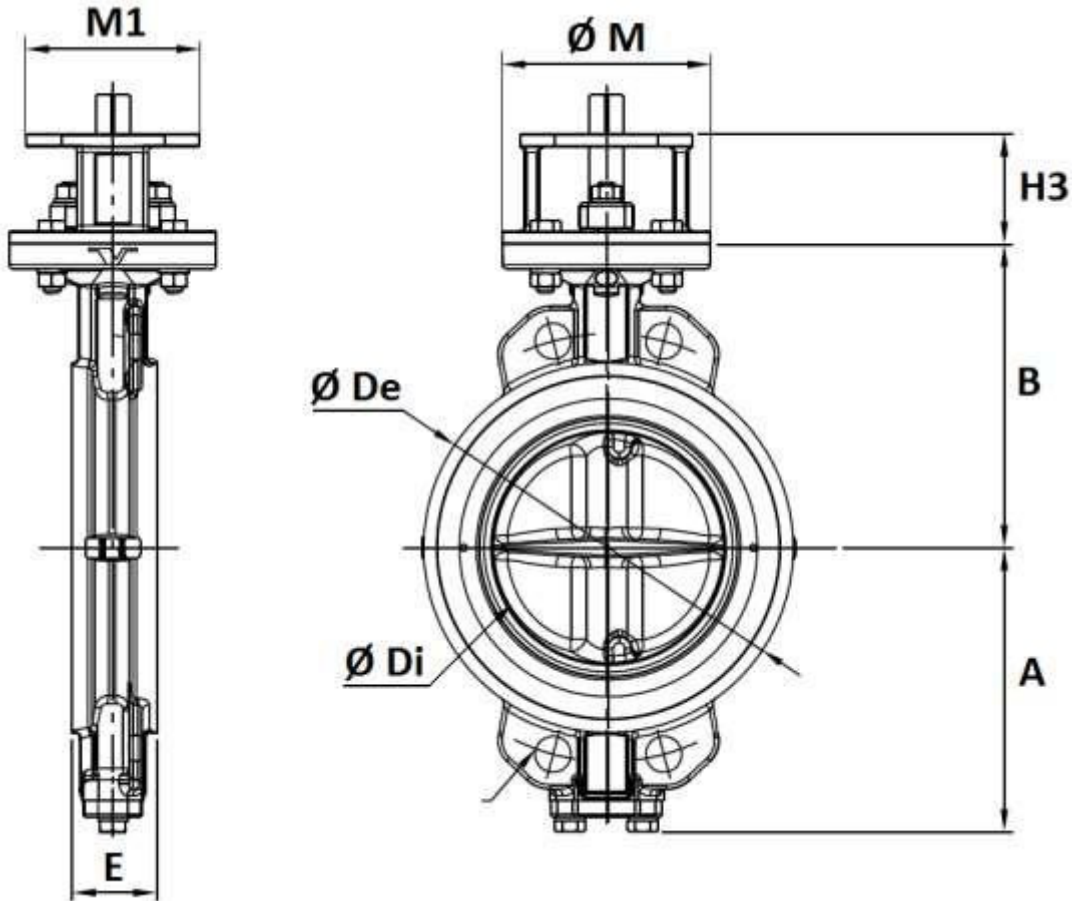
CARBON STEEL DOUBLE OFFSET WAFER BUTTERFLY VALVE PN16/25 FIRE SAFE
VALVE SIZE DN200 - 400 (in mm) :

DN	200	250	300	350	400
E	62	68	78	78	102
A	206	238	269	306	342
B	220	260	290	326	370
H3	80	80	100	100	120
Ø M	150	150	175	175	210
M1	125	125	160	160	195
Ø De	268	326	375	416	476
Ø Di	187.6	235.5	282	322	371
Min pipe diameter	196	243	289	329	377
Weight (in Kg)	22	32	48	66	107

CARBON STEEL DOUBLE OFFSET WAFER BUTTERFLY VALVE PN16/25 FIRE SAFE

VALVE SIZE DN450 - 600 (in mm) :

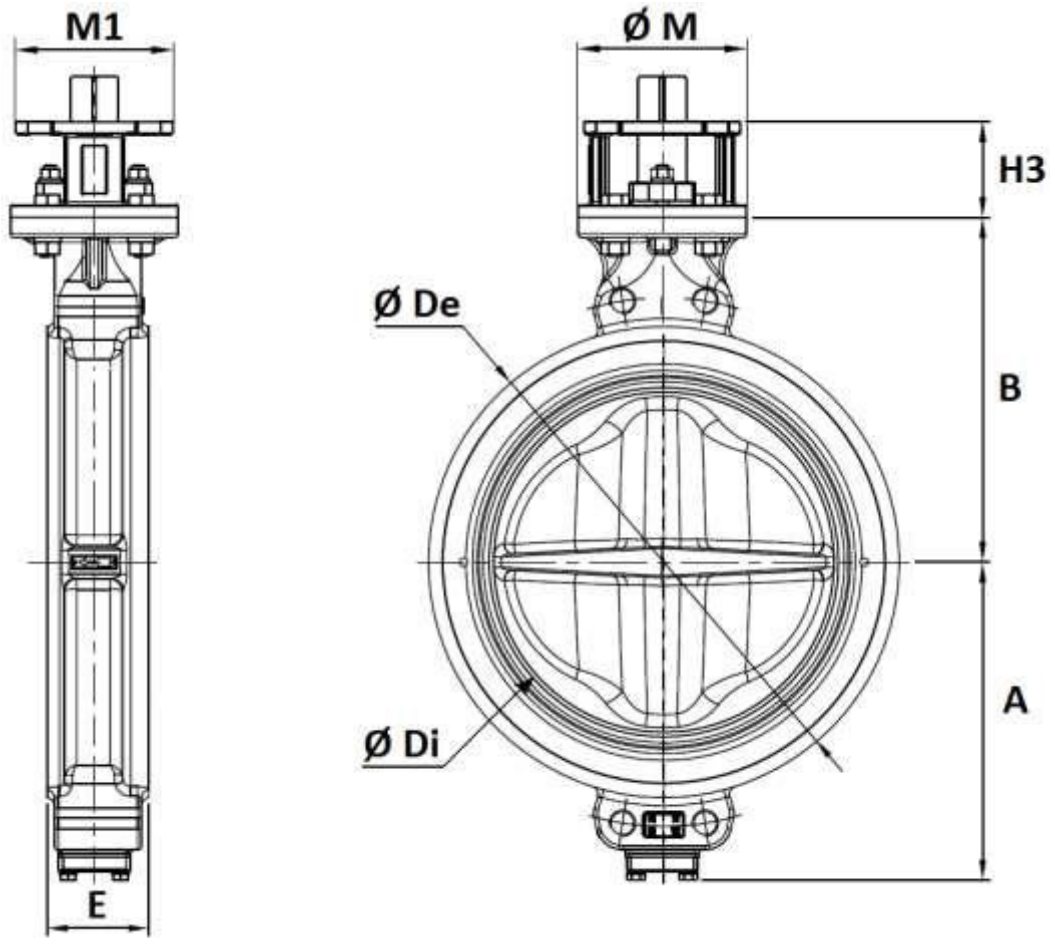

DN	450	500	600
E	114	127	154
A	370	399	455
B	395	430	490
H3	120	120	150
Ø M	210	210	300
M1	195	195	300
Ø De	534	588	692
Ø Di	418	466	570
Min pipe diameter	423	471	572
Weight (in Kg)	130	163	278

CARBON STEEL DOUBLE OFFSET WAFER BUTTERFLY VALVE PN16/25 FIRE SAFE

HANDLE SIZE (in ductile iron EN GJS-400-15 with silver painting RAL 9006 color) :



DN	50	65	80	100	125	150
L	200	200	250	250	355	355
Weight (Kg)	0.7	0.7	0.8	0.8	1.6	1.6

CARBON STEEL DOUBLE OFFSET WAFER BUTTERFLY VALVE PN16/25 FIRE SAFE

GEARBOX SIZE DN 50-350 :

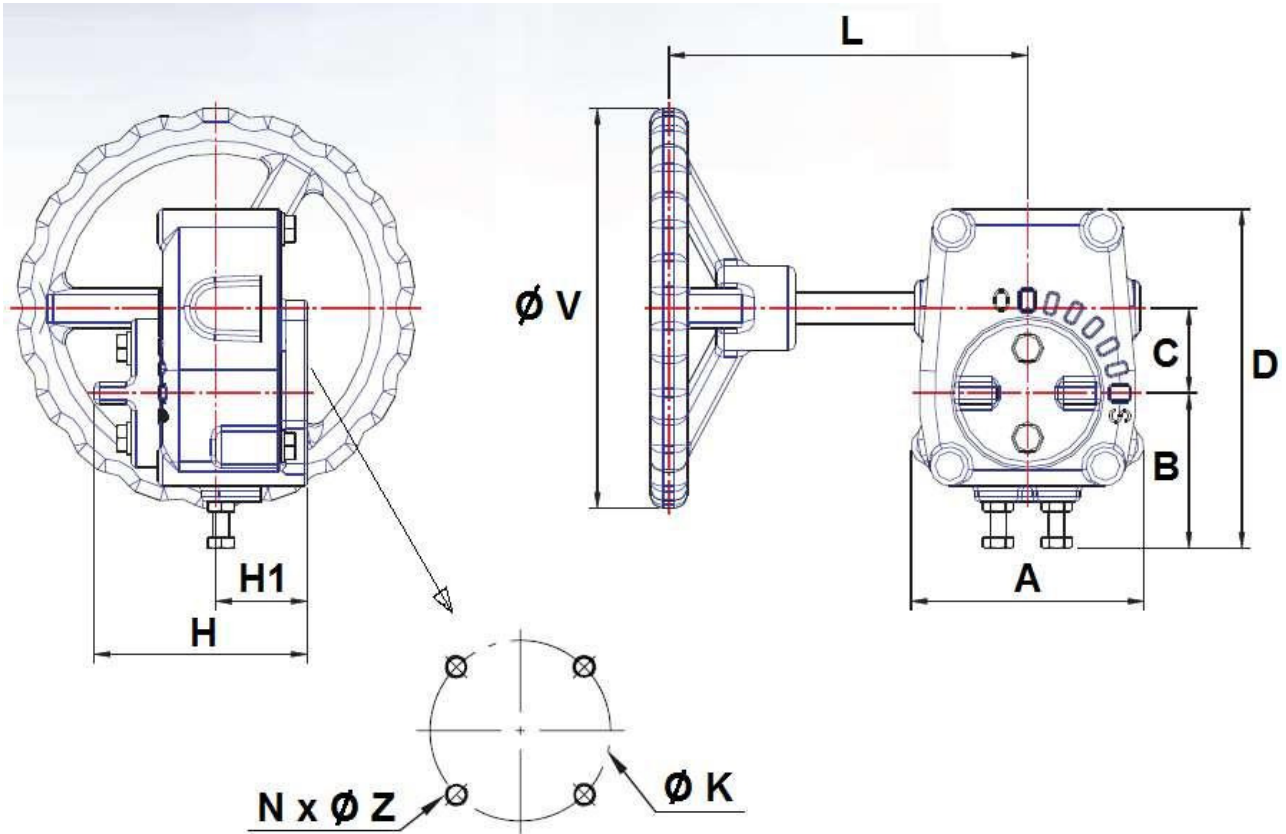

DN	50-65	80	100	125-150	200	250	300-350
L	155	155	195	195	258	258	346
A	87	87	117	117	153	153	181
B	49	49	81	81	97	97	102
C	41	41	63	63	61	61	81
D	130	130	176	176	186	186	223
H	81	81	91	91	88	88	117
H1	37	37	41.5	41.5	41	41	52
Ø V	150	150	200	200	310	310	400
Ø K	70	70	102	102	125	125	140
ISO	F07	F07	F10	F10	F12	F12	F14
N x Ø Z	4 x M8	4 x M8	4 x M10	4 x M10	4 x M12	4 x M12	4 x M16
Weight (Kg)	3.3	3.3	7.5	7.5	9	9	22
Ref.	1193001	1193002	1193003	1193004	1193005	1193006	1193007

CARBON STEEL DOUBLE OFFSET WAFER BUTTERFLY VALVE PN16/25 FIRE SAFE

GEARBOX SIZE DN 400-500 :

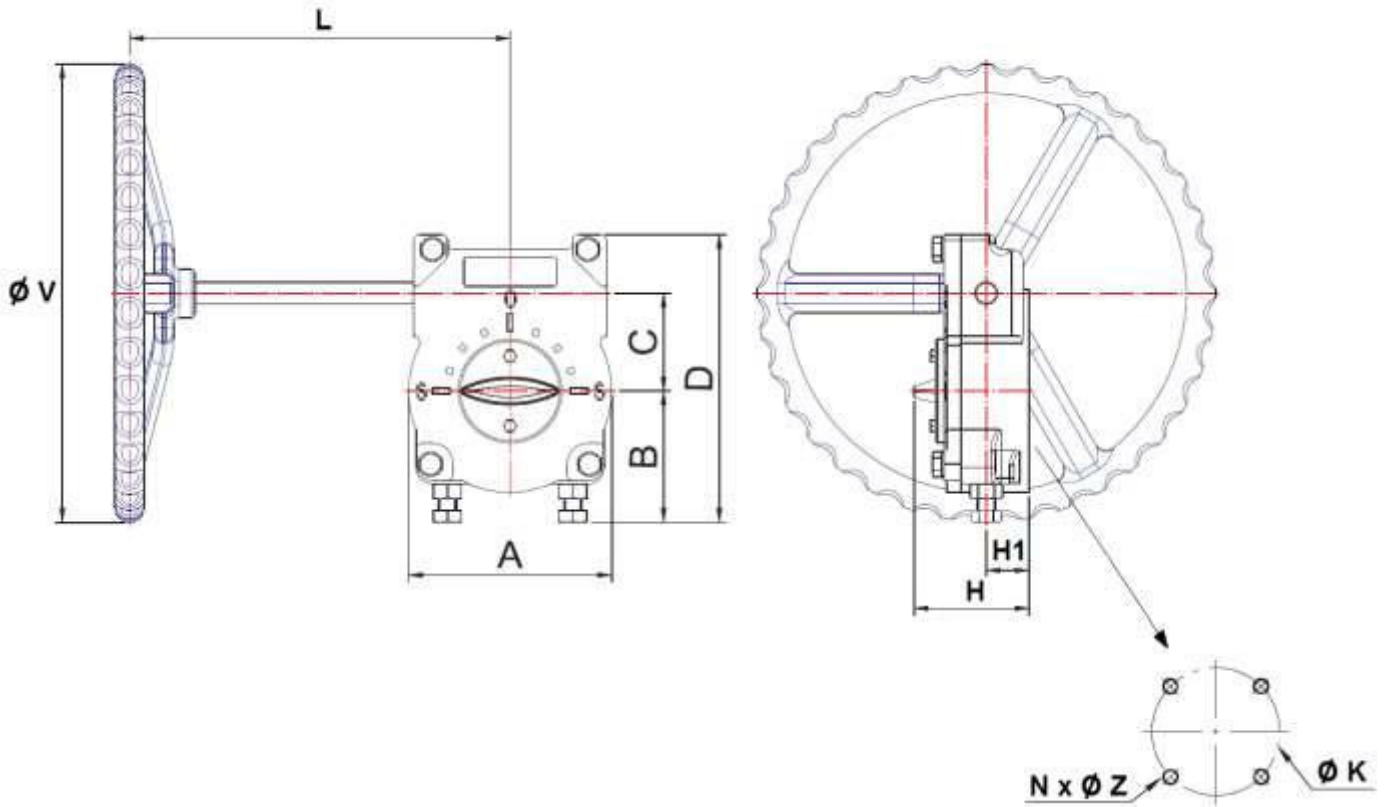

DN	400-500
L	307
A	251
B	113
C	123
D	293
H	127
H1	56
Ø V	400
Ø K	165
ISO	F16
N x Ø Z	4 x M20
Weight (Kg)	35

CARBON STEEL DOUBLE OFFSET WAFER BUTTERFLY VALVE PN16/25 FIRE SAFE

GEARBOX SIZE DN 600 :

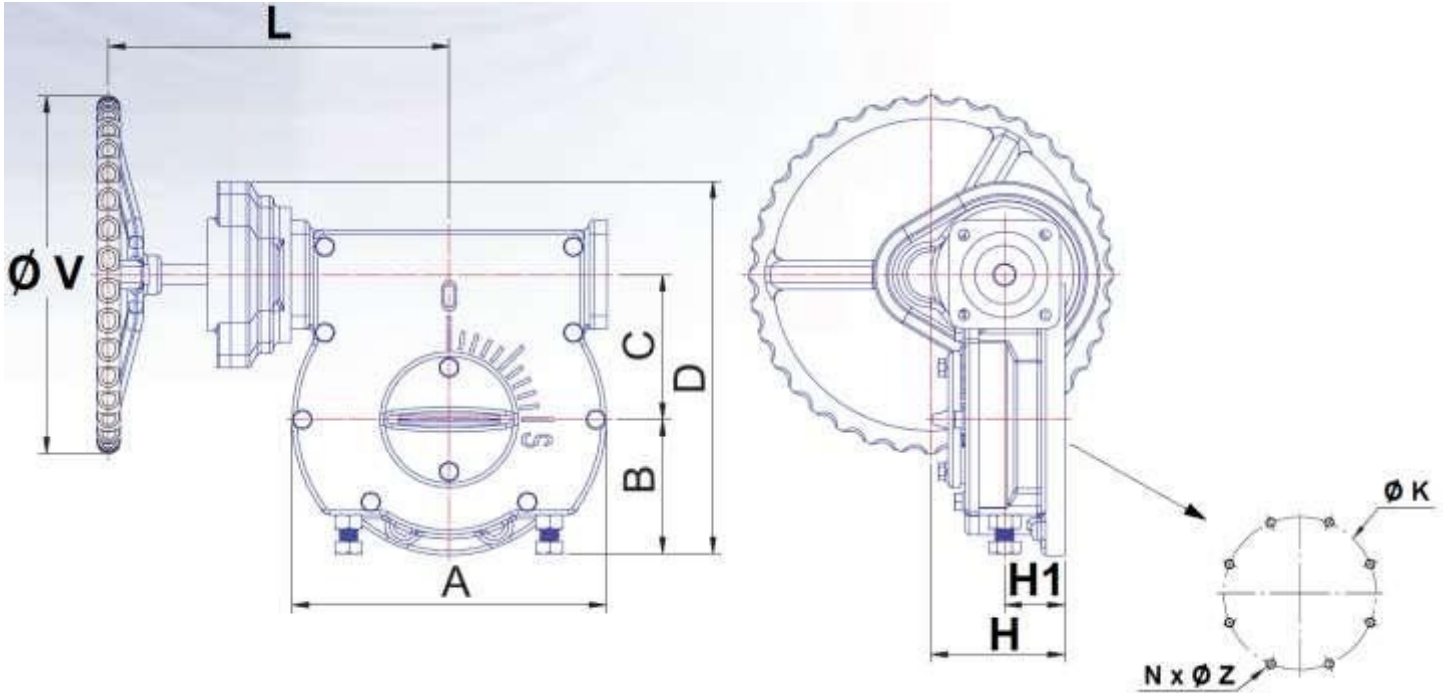

DN	600
L	370
A	341
B	148
C	160
D	411
H	145
H1	65
ØV	400
ØK	254
ISO	F25
N x ØZ	8 x M16
Weight (Kg)	109

CARBON STEEL DOUBLE OFFSET WAFER BUTTERFLY VALVE PN16/25 FIRE SAFE

GEARBOX SPECIFICATIONS :

DN	50-65	80	100	125-150	200-250	300-350	400-500	600
Ref.	1193001	1193002	1193003	1193004	-	-	-	-
Ratio factor	40 :1	40 :1	36 :1	36 :1	36 :1	52 :1	70 :1	207 :1
Number of cycles for opening or closing	10	10	9	9	9	13	17.5	52
Input torque (Nm)	24.5	24.5	54	54	109	150	225	451
Output torque (Nm)	245	245	490	490	980	1960	3922	7845

CARBON STEEL DOUBLE OFFSET WAFER BUTTERFLY VALVE PN16/25 FIRE SAFE

ISO MOUNTING PAD AND STEM SIZE (in mm) :

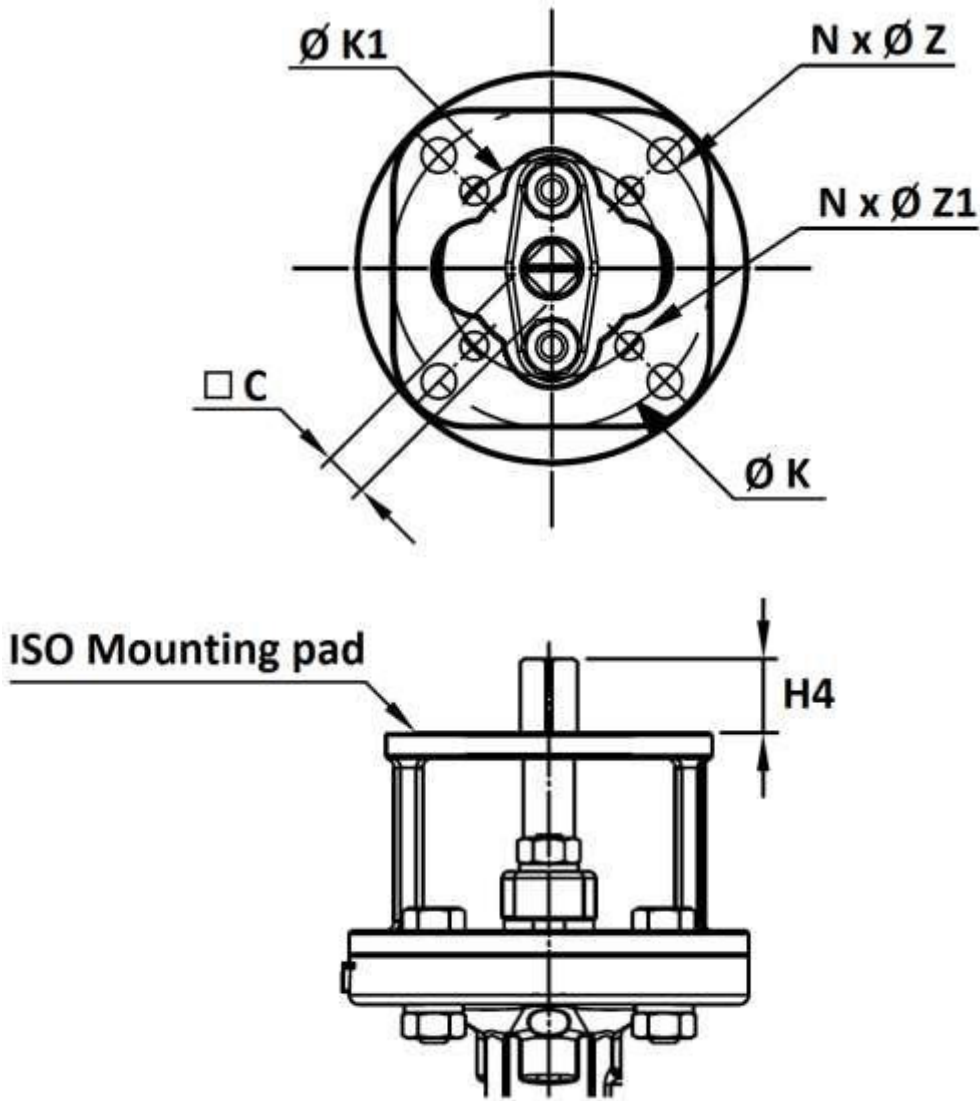

DN	50	65	80	100	125	150	200	250	300	350	400	450	500	600
C	11	11	14	14	17	17	19	22	27	27	36	36	46	46
H4	18	18	23	23	23	23	28	28	37	37	47	47	56	56
$\varnothing K$	70	70	102	102	102	102	125	125	140	140	165	165	165	254
ISO	F07	F07	F10	F10	F10	F10	F12	F12	F14	F14	F16	F16	F16	F25
$N \times \varnothing Z$	4 x 8	4 x 8	4 x 10	4 x 10	4 x 10	4 x 10	4 x 12	4 x 12	4 x 16	4 x 16	4 x 22	4 x 22	4 x 22	8 x 17
$\varnothing K1$	50	50	70	70	70	70	102	102	125	125	140	140	140	-
ISO1	F05	F05	F07	F07	F07	F07	F10	F10	F12	F12	F14	F14	F14	-
$N \times \varnothing Z1$	4 x 6	4 x 6	4 x 8	4 x 8	4 x 8	4 x 8	4 x 10	4 x 10	4 x 12	4 x 12	4 x 16	4 x 16	4 x 16	-

CARBON STEEL DOUBLE OFFSET WAFER BUTTERFLY VALVE PN16/25 FIRE SAFE

BETWEEN FLANGES PN25 SIZE (in mm) :

DN 50 – 150

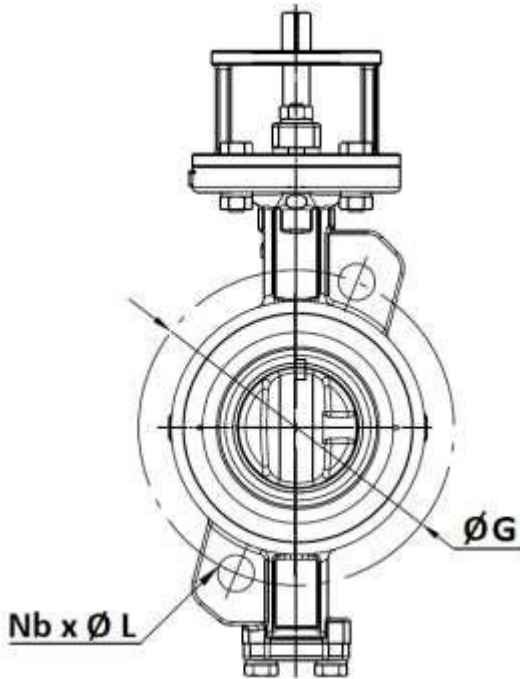

DN 200 - 400

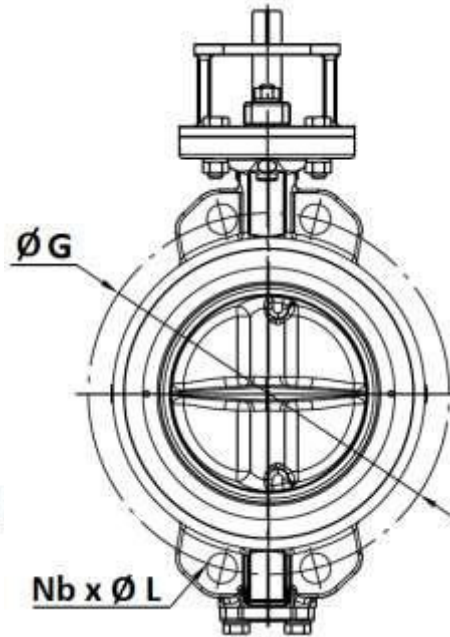

DN 450 - 600

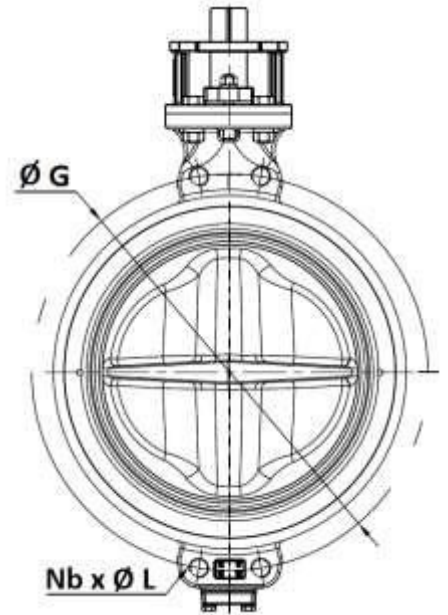

PN	PN25													
DN	50	65	80	100	125	150	200	250	300	350	400	450	500	600
Ø G	125	145	160	190	220	250	310	370	430	490	550	600	660	770
Nb x ØL	2 x 18	2 x 18	2 x 18	2 x 22	2 x 26	2 x 26	4 x 26	4 x 30	4 x 30	4 x 33	4 x 36	4x M33	4x M33	4x M36
Ref.	1113050	1113065	1113080	1113100	1113125	1113150	1113200	1113250	1113300	1113350	1113400	1113450	1113500	1113600

CARBON STEEL DOUBLE OFFSET WAFER BUTTERFLY VALVE PN16/25 FIRE SAFE

BETWEEN FLANGES PN16 SIZE (in mm) :

DN 100 – 150

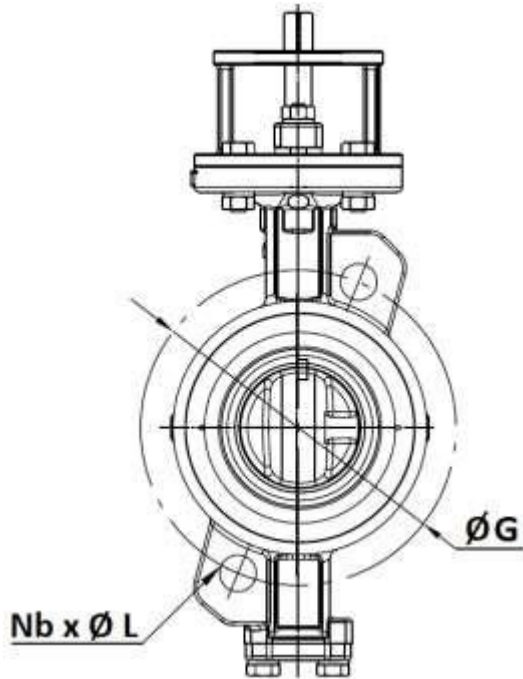

DN 200 - 300

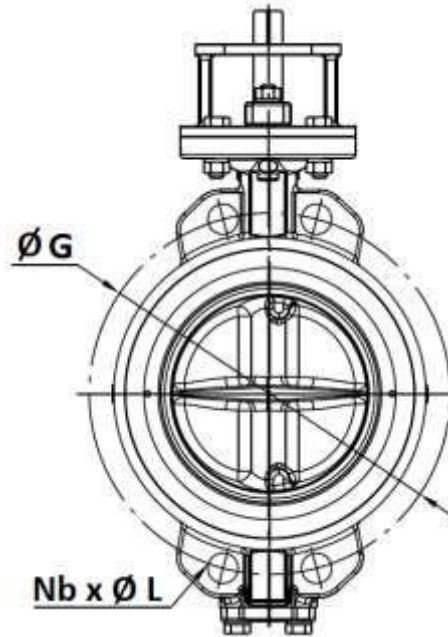

PN	PN16					
DN	100	125	150	200	250	300
Ø G	180	210	240	295	355	410
Nb x ØL	2 x 18	2 x 18	2 x 22	4 x 22	4 x 26	4 x 26
Ref.	1113101	1113125	1113151	1113201	1113251	1113301

CARBON STEEL DOUBLE OFFSET WAFER BUTTERFLY VALVE PN16/25 FIRE SAFE

BOLTING SIZE PN25 (in mm, not included with valves) :

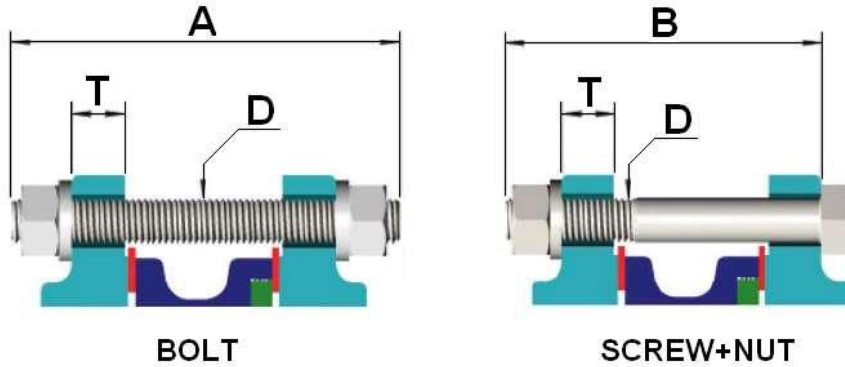

PN25														
DN	50	65	80	100	125	150	200	250	300	350	400	450	500	600
A	130	140	145	160	180	180	190	210	220	235	270	300	310	370
B	125	125	130	140	155	155	165	180	195	205	240	265	280	330
D	M16	M16	M16	M20	M24	M24	M24	M27	M27	M30	M33	M33	M33	M36
T	22	22	24	24	26	28	30	32	34	38	40	48	48	58

BOLTING SIZE PN16 (in mm, not included with valves) :

PN16						
DN	100	125	150	200	250	300
A	145	150	165	165	190	205
B	130	135	140	145	165	180
D	M16	M16	M20	M20	M24	M24
T	22	22	24	24	26	28

BOLTING TIGHTENING TORQUE :

Bolting dimension	Max Torque (Nm)
M16	150
M20	270
M22	434
M24	450
M26	650
M27	700
M28	815
M30	950
M32	1140
M33	1300
M36	1700

CARBON STEEL DOUBLE OFFSET WAFER BUTTERFLY VALVE PN16/25 FIRE SAFE

STANDARDS :

- Manufacturer certified ISO 9001:2015
- DIRECTIVE 2014/68/EU : For liquids and gas of Group 1
 - PN16 types :
 - DN50-65 : Risk Category I, CE 0035 marking
 - DN80-200 : Risk Category II, CE 0035 marking
 - DN250-600 : Risk Category III, CE 0035 marking
 - PN25 types :
 - DN50-125 : Risk Category II, CE 0035 marking
 - DN150-600 : Risk Category III, CE 0035 marking
- Designing according to API 609
- Marking according to MSS SP-25
- Tightness tests according to ISO 5208, Rate A
- Between flanges according to EN 1092-1 PN25 or PN16
- ISO 5211 mounting pad
- Length according to EN 558 series 20 (ISO 5752 series 20)
- Fire safe according to ISO 10497 : 2010
- ATEX Group II Category 2 G/2D Zone 1 & 21 Zone 2 & 22 according to directive 2014/34/EU (Optional marking)
- SIL2 according to IEC/EN 61508, SIL 3 possible according to installation

ADVICE : Our opinion and our advice are not guaranteed and SFERACO shall not be liable for the consequences of damages.
The customer must check the right choice of the products with the real service conditions.