

1110 BUTTERFLY VALVES WITH AP RE PNEUMATIC ACTUATORS

FEATURES

The 1110 double-offset butterfly valve is a high-performance valve. It is designed for the automatic shut-off of high-pressure and/or high- and low-temperature fluid pipes such as steam, bitumen, heating oils, alkalis, etc. The valve has a direction of mounting, but the seat leakage is, however, bi-directional. The single-block stem of the butterfly is mounted on bearings and has an antistatic device. The ISO 5211 mounting pad enables standardised actuators to be mounted. The AP RE (adjustable stops) actuator pneumatic motorisation is available in double and spring-return with numerous options.

AVAILABLE MODELS

1110: carbon steel body.
DN 50 to DN 300, FAF according to ISO 5752 series 20.
EN 1092 PN16 or PN 25 RF wafer mounting.
Double and spring-return actuator.



Sur demande



LIMITS OF USE

Fluid pressure: PS	25 bar
Fluid temperature: WT	Steel: -29°C / +210°C
Ambient temperature	-15°C / +80°C
Motor compressed air	mini 6 bar / maxi 10 bar

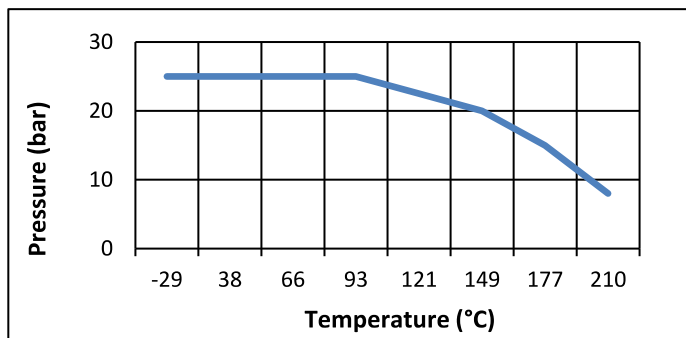

DIRECTIVES AND MANUFACTURING STANDARDS

OBJET	Standard	OBJET	Standard
Pressure Equipment Directive 2014/68/EC	Cat.II Group 1 DN50 to 125 - CE 0035 Cat.III Group 1 DN150 to 300 CE 0035	Flange dimension	EN 1092-1
ATEX Directive 2014/34	II 2G/D zones 1,2,21,22	Face to face dimension	ISO 5752 series 20
Construction	API 609	Actuator pilot connection	NAMUR
Body materials	EN 1503-2	Switch box connection	VDI/VDE 3845
Material certificate	EN 10204	Connection Motorization	ISO 5211
Final test	ISO 5208 and MSS SP-25	SIL 3 level (actuator alone)	EN 61508

Information given as an indication only, and subject to possible modifications



1110 BUTTERFLY VALVES WITH AP RE PNEUMATIC ACTUATORS

CONSTRUCTION

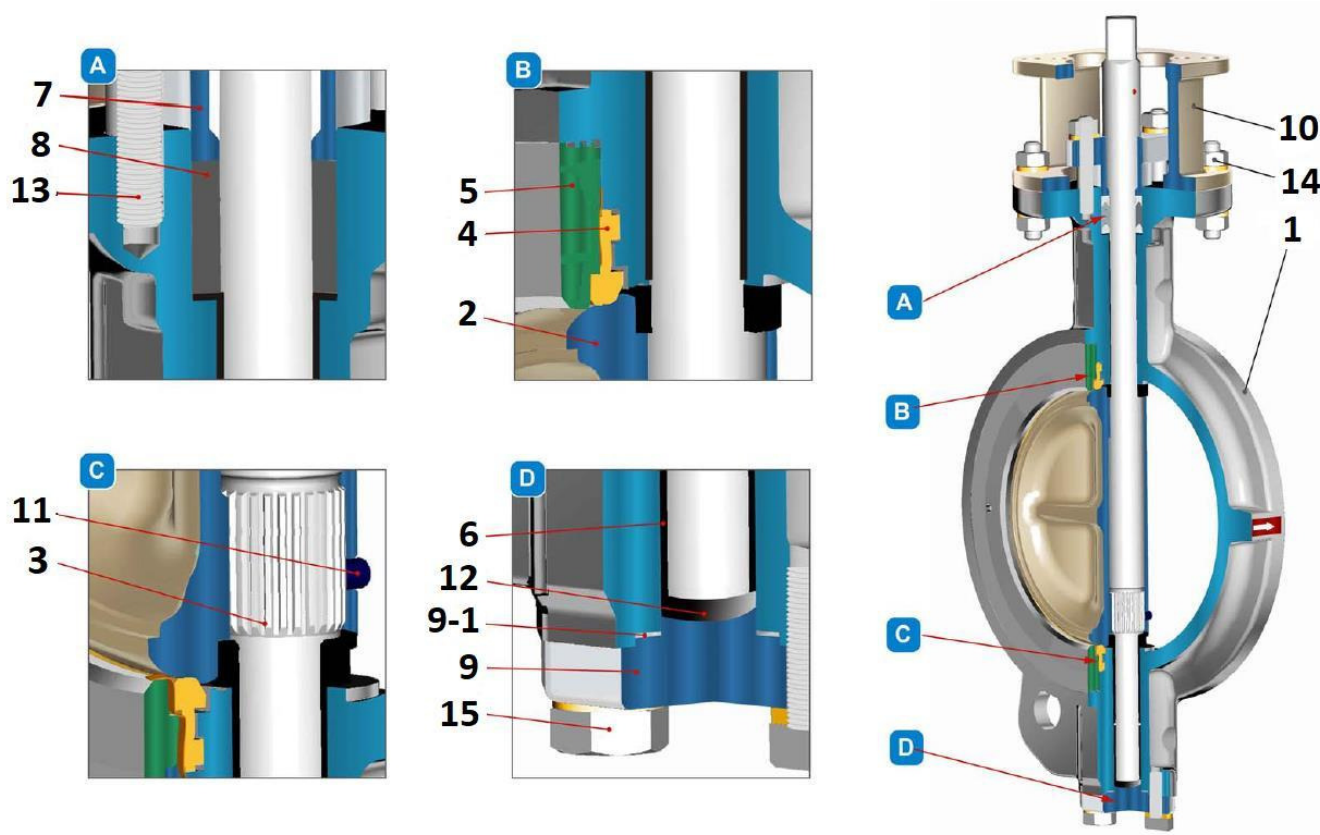

* Included in gaskets kit

No.	Name	1110 materials
1	Body	1.609 carbon steel
2	Butterfly	1.4408 SS
3	Shaft	ASTM A564 630
4*	Seat	PTFE + 15 % graphite
5	Retainer	1.4308 SS
6*	Ring	PTFE + stainless steel
7	Gland	1.4308 SS
8*	Gland packing	PTFE filled with 15 % graphite
9	Bottom cover	1.609 carbon steel
9-1*	Bottom cover gasket	PTFE filled with 15 % graphite
10	Yoke	1.609 carbon steel
11*	Stop stud	ASTM A 193 Gr. B8M
12	Ring	PTFE filled with 15 % graphite + AISI 316
13	Stud	ASTM A 193 Gr. B8
14	Nut	ASTM A 194 Gr. 8
15	Bolt	ASTM A 193 Gr. B8

Information given as an indication only, and subject to possible modifications



1110 BUTTERFLY VALVES WITH AP RE PNEUMATIC ACTUATORS

DIMENSIONS (mm)

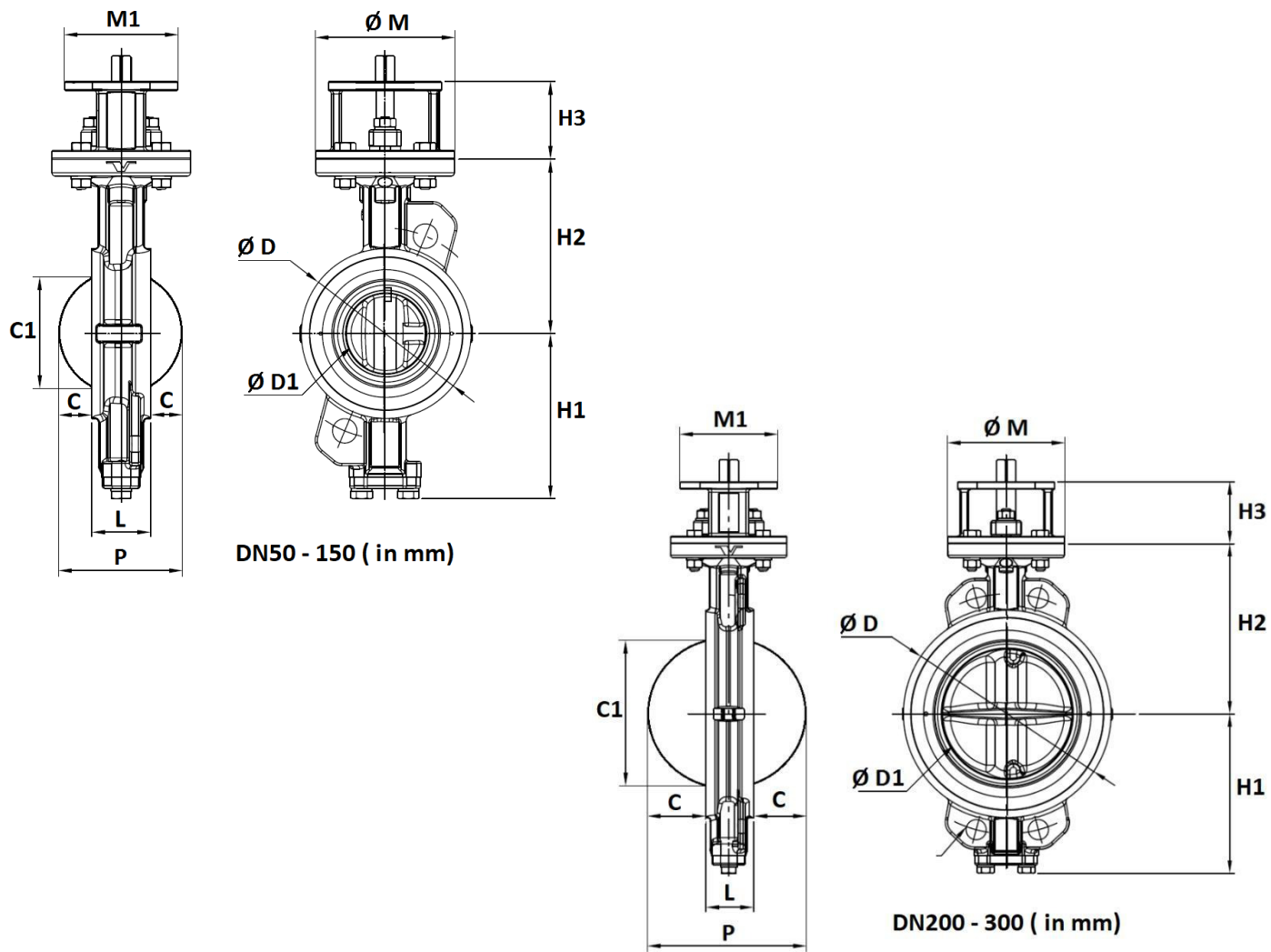

DN	L	H1	H2	H3	Ø D	Ø D1	C	C1	ØM	M1	P	Min pipe diameter	Weight (Kg)
50	43	99	118	60	92	37	2	49,5	90	70	47	49	3,9
65	46	110	125	60	108	63	15	62,3	90	70	76	62	4,5
80	47	128	140	70	126	78	22	65,9	125	102	91	78	7
100	53	150	157	70	153	95	25	93	125	102	103	93	9
125	57	163	170	70	184	118	36	120	125	102	129	120	12
150	56	176	185	70	212	143	50	149	125	102	156	149	13,5
200	62	206	220	80	268	187,6	70	196	150	125	202	196	22
250	68	238	260	80	326	235,5	90	243	150	125	248	243	32
300	78	269	290	100	375	282	106	289	175	160	290	289	48

Information given as an indication only, and subject to possible modifications



1110 BUTTERFLY VALVES WITH AP RE PNEUMATIC ACTUATORS

FLOW-RATE COEFFICIENT Kv (m³/h)

DN	Opening angle									
	10°	20°	30°	40°	50°	60°	70°	80°	90°	100°
50	3,5	11,2	22,5	33,7	62,3	109,0	132,3	176,4	201,5	138,4
65	6,1	19,9	38,9	57,1	105,5	185,1	223,1	298,4	339,9	224,0
80	8,6	29,4	58,8	87,4	160,0	280,2	338,2	452,3	515,5	344,2
100	9,5	35,5	62,3	95,1	185,1	324,3	359,8	467,9	497,3	530,2
125	14,7	45,8	91,7	135,8	20,8	437,6	528,4	705,7	805,2	847,6
150	20,8	66,6	131,5	195,5	360,7	629,6	761,1	1017,1	1158,9	1189,2
200	36,3	118,5	234,4	347,7	472,2	661,6	851,0	1126,9	1254,1	1513,5
250	108,1	263,8	425,5	504,2	798,3	1089,7	1427,1	1781,7	2110,3	2306,6
300	147,0	358,9	578,6	834,6	1124,3	1517,9	2645,7	2987,3	3328,9	3776,1

BOLTING SIZE PN25 (in mm, not included with valves)

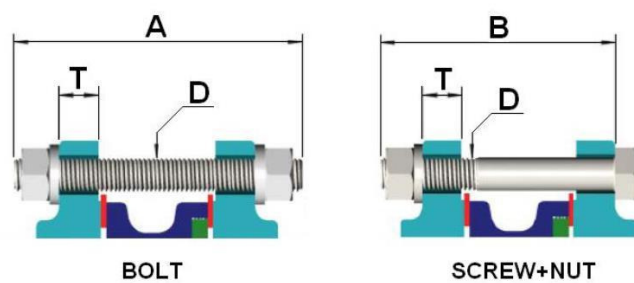

DN	50	65	80	100	125	150	200	250	300
A	130	140	145	160	180	180	190	210	220
B	125	125	130	140	155	155	165	180	195
D	M16	M16	M16	M20	M24	M24	M24	M27	M27
T	22	22	24	24	26	28	30	32	34

BOLTENING TORQUES

Bolding size	Max torque (Nm)
M16	150
M20	270
M22	434
M24	450
M26	650
M27	700

Information given as an indication only, and subject to possible modifications



1110 BUTTERFLY VALVES WITH AP RE PNEUMATIC ACTUATORS

AP RE PNEUMATIC MOTORIZATION

The ALPHAIR RE motorisation proposed as standard comprises:

- rack and pinion actuator of anodised aluminium.
- a safety coefficient of 1.3 minimum compared to the nominal torque of the valve.
- air non-lubricated dry motor, minimum 6 bar pressure.
- an upstream / downstream pressure difference $\Delta P=20$ bar max.

The actuator mounting is direct apart from the DN250 with RES (yoke + stainless steel driver according to the EN 15081 standard).

DN	Double-effect	V (liters)	Time (s)*	Spring-return	V (liters)	Time (s)*
50	RE 76	0.61	1	RES 86/6	0.98	2
65	RE 76	0.61	1	RES 86/6	0.98	2
80	RE 76	0.61	1	RES 101/6	1.80	2
100	RE 86	0.98	2	RES 116/6	2.80	2
125	RE 101	1.80	2	RES 126/6	3.70	3
150	RE 116	2.80	2	RES 146/6	4.90	3
200	RE 126	3.70	3	RES 161/6	8.00	3
250	RE 126	3.70	3	RES 181/6	11.1	5
300	RE 146	4.90	3	RES 201/6	14.2	6

For any other operating conditions, please contact us.

*indicative time of the no-load actuator for opening or closing.

MOTORIZATION OPTIONS

1	actuators dimensioned for a compressed air pressure of 3, 4 or 5 bar
2	actuator dimensioned for an upstream / downstream pressure difference ΔP greater than 10 bar
3	actuator with special coatings, stainless steel actuator
4	Actuator for very low (-60°C) or very high ($+150^{\circ}\text{C}$) ambient temperatures.
5	manual override with declutchable gear box
6	compressed air filter regulator
7	All types of piloting solenoid valves
8	all types of switch boxes
9	all types of positioner
10	rapid exhaust, flow-rate limiters - exhaust brakes
OPTIONS ON THE VALVE	
1	Drilling of the centring lugs for PN16 flanges according to EN 1092-1 and ANSI 150 according to ANSI B16.5
2	Threaded lugs connections
3	Fire safety : model 1113 and 1114

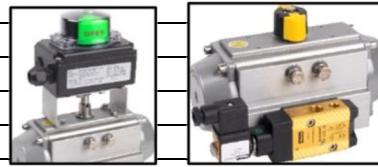

INSTALLATION IN AN ATEX ZONE

For 1110+AP RE automatic valves to be installed in ATEX 1, 2, 21 or 22 zones, this has to be specified when ordering. Our services will check of the assembly, the installation of an earthing braid, and will issue an assembly certificate. Our authorised technicians carry out these operations in the workshop. Please contact us. The special assembly and maintenance instructions for motorised valves in the ATEX zones must be followed.

Information given as an indication only, and subject to possible modifications



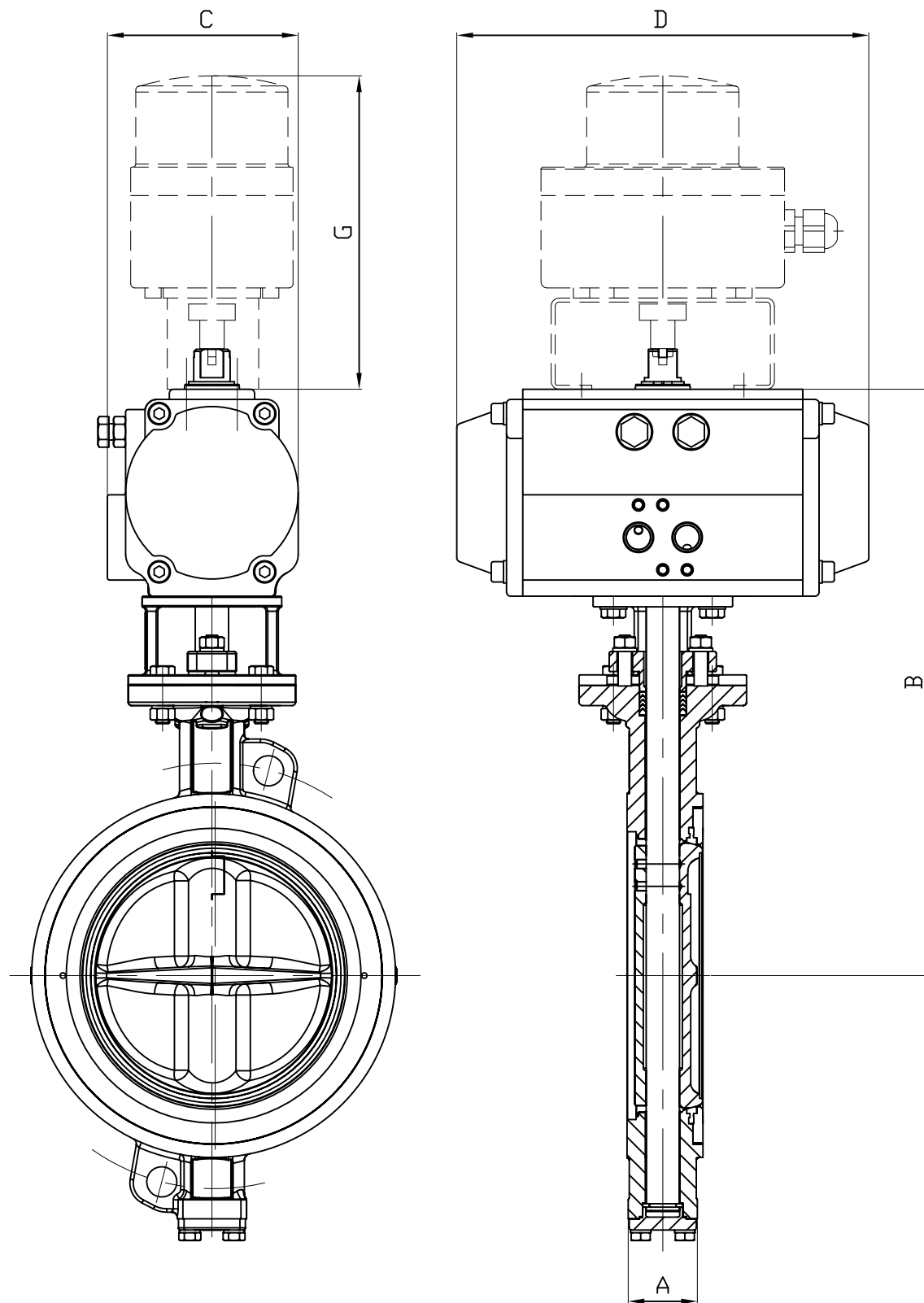

DN	50		65		80		100		125		150		200		250		300	
ALPHAIR	RE76	RES86	RE76	RES86	RE76	RES101	RE86	RES116	RE101	RES126	RE116	RES146	RE126	RES161	RE126	RES181	RE146	RES201
A	43		46		47		53		57		56		62		68		78	
B	280	290	287	297	311	337	339	372.5	367	397.5	400.5	432	457.5	496	497.5	640*	567	636
C	94	104	94	104	94	120	104	134	120	145	134	165	145	182	145	204	165	222
D	203	239	203	239	203	261	239	304	261	333	304	398	333	424	333	482	398	528
G	154.5		154.5		154.5		154.5	164.5	154.5	164.5	164.5		164.5	184.5	164.5	184.5	164.5	184.5
Kg	6.85	8.65	7.45	9.25	10.1	13.93	13.25	19.1	18	25	22.2	30.3	33.2	46.1	43.2	59.6	64.93	94.2

Informations données à titre indicatif et sous réserve de modifications éventuelles
data subject to alteration

* Montage avec platine supplémentaire H=80mm