

BUTTERFLY VALVE 1115-1116 + ELECTRIC SERVOMOTOR NA

FEATURES

The 1115-1116 double offset butterfly valve is a high performance valve. It is intended for the automatic sectioning of high pressure and/or high and low temperature fluid lines such as steam, bitumen, thermal oils, alkali, etc. The faucet has one direction of assembly, however, the sealing is bidirectional. The one-piece throttle shaft is mounted on bearings and has an antistatic device. The fire safety construction of the tap allows its use in the hydrocarbon sector. The ISO 5211 plate allows direct mounting of the NA servomotor. This is perfectly suited to industrial use indoors and outdoors.

AVAILABLE MODELS



N/A



NA-X



with NA-X



1115: carbon steel body.

1116: stainless steel body.

Diameters 2" to 12", FAF according to ISO 5752 series 20.

Mounting between ANSI 150 RF flanges according to ANSI B16.5.

Supply voltages : 24 Vac-dc, 230 Vac, tri 400 V.

LIMITS OF USE

Fluid pressure: PS	20 bar
Fluid temperature: TS	Steel: -25°C / +210°C Stainless steel: -30°C / +210°C
Ambient temperature	-20°C / +70°C
Service factor	S2 - 70%

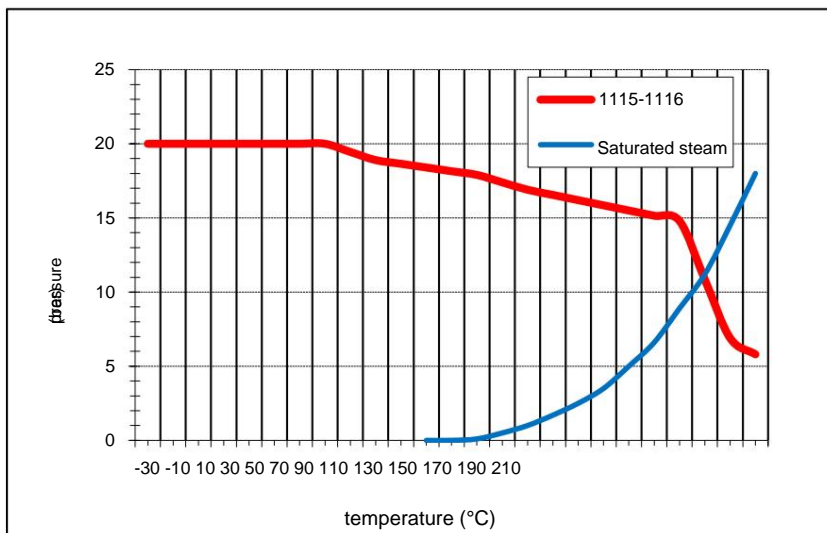

Information given for information purposes only and subject to possible modifications



BUTTERFLY VALVE 1115-1116 + ELECTRIC SERVOMOTOR NA

CONSTRUCTION GUIDELINES AND STANDARDS

OBJECT	Standard
CE pressure directive 2014/68	Cat.III Module H - CE 0035
ATEX Directive	EN 13463-1: II 2G/D
Construction	API 609 and MSS SP-68
Body materials	EN 1503-2
Material certificate	EN 10204
Flange dimensions	ANSI B16.5
Face to face dimension	ISO 5752 series 20
In-line sealing	ANSI/FCI 70-2
Final test	ISO 5208 and MSS SP-61
Fire safety	API 607/5 – ISO 10497-5
Connection Motorization	ISO 5211
Connection actuator driver	NAMUR
Connection limit switch box	VDI/VDE 3845
SIL level 3 (actuator)	EN 61508

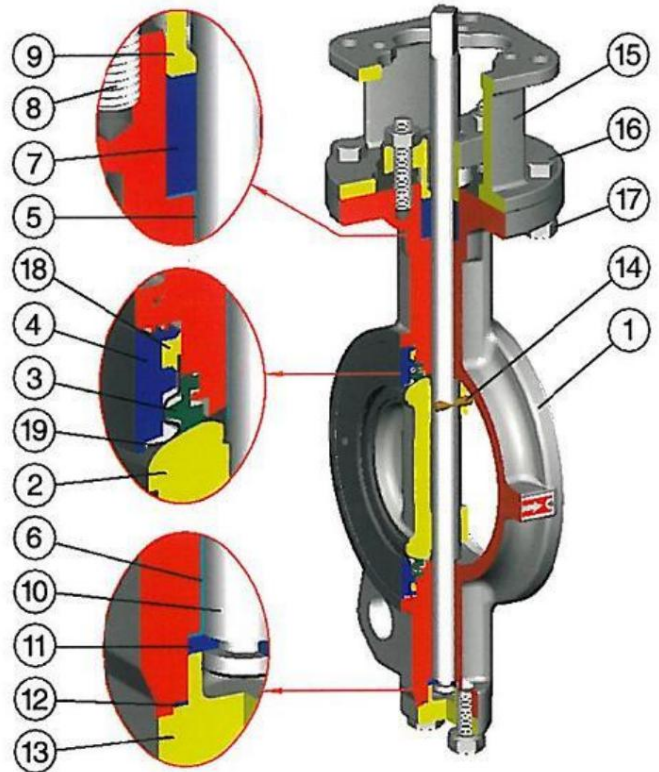

CONSTRUCTION

Rep.	Designation	Materials 1115	Materials 1116
1	Body	A216 WCB carbon steel	Stainless steel A351 CF8M
2	Butterfly	Stainless steel A351 CF8M	
3	Seat	PTFE + 15% graphite	
4	Flask	Stainless steel 1.4308	
5	Ring	PTFE + stainless steel	
6	Ring	PTFE + stainless steel	
7	Trim	Graphite	
8	<small>Screw</small>	ASTM A 193 B8	
9	Pluggers	Stainless steel A351 CF8M	
10	Axis	Stainless steel 364 630	
11	Landing	Stainless steel ASTM A240 Gr. 316	
12	Gasket	Graphite	
13	Stopper	A216 WCB carbon steel	Stainless steel A351 CF8M
14	Key	ASTM A 182 F316	
15	Arcade	A216 WCB carbon steel	Stainless steel A351 CF8M
16	Screws	ASTM A 193 B8	
17	Nut	ASTM A 194 B8	
18	Waterproofing	Graphite	
19	Metal seat	Stainless steel ASTM A240 Gr. 316	

Information given for information purposes only and subject to possible modifications

BUTTERFLY VALVE 1115-1116 + ELECTRIC SERVOMOTOR NA

DIMENSIONS (mm)

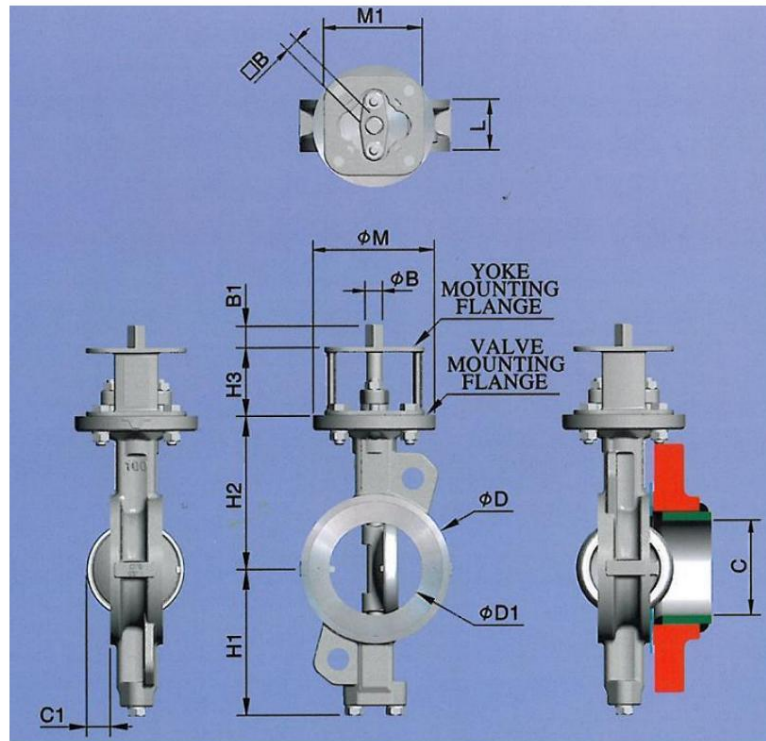

Diameter	L	H1	H2	H3	ØD	Ø D1	vs	C1	Weight (in Kg)
2"	43	99	118	60	92	57	49	2	3.9
2" 1/2	46	110	125	60	108	63	62	15	4.5
3"	47	128	140	70	126	78	78	22	7
4"	53	150	157	70	153	95	93	25	9
5"	57	163	170	70	184	118	120	36	12
6"	56	176	185	70	212	143	149	50	13.5
8"	62	206	220	80	268	188	196	70	22
10"	68	238	260	80	326	236	243	90	32
12"	78	269	290	100	375	282	289	106	48

FLOW COEFFICIENT Kv (m3 /h)

Diameter	2"	2" 1/2	3"	4"	5"	6"	8"	10"	12"
Kv	56	119	222	358	615	1709	1709	2649	4059

Information given for information purposes only and subject to possible modifications



BUTTERFLY VALVE 1115-1116 + ELECTRIC SERVOMOTOR NA

NA ELECTRIC MOTORIZATION

The NA engine offered as standard is intended for:

- IP67 epoxy coated aluminum housing actuator and steel gearbox.
- safety coefficient 1.3 minimum compared to the nominal torque of the valve.
- upstream/downstream pressure difference $\Delta P=10$ bar maximum.

The actuator assembly is of the steel arch + driver type.





DN	Servomotor Power (W)	Time (s)*		Servo motor standard equipment
2"	NA 06	15W	17 sec	2 adjustable limit switches + 2 dry auxiliaries 20 W anti-condensation resistor Visual position indicator Motor thermal protection (NA 06 and NA09) Torque limiter (NA15 to NA38) Connection electrical : 2 M20 x 1.5 cable glands Emergency manual control by detachable steering wheel
2" 1/2	NA 06	15W	17 sec	
3"	NA 06	25W	17 sec	
4"	NA 09	25W	17 sec	
5"	NA 15	40W	20 sec	
6"	NA 28	40W	24 sec	
8"	NA 28	40W	24 sec	
10"	NA 38	60W	24 sec	
12"	NA 38	60W	24 sec	

For any other service conditions, please contact us.

*indicative time of the actuator when empty

ENGINE OPTIONS

There are many options for which we ask you to consult our sales department:

1	2	3	4	5
NA LCU : Servo motor with local command	NA PCU : servo motor 4-20mA regulation or 0-10V	NA RBP : safety servomotor with safety block battery	NA-X : actuator for use in zones ATEX 1 and 2	RS : servo motor recoil safety spring
				
6	servomotor sized for upstream/downstream pressure difference ΔP greater than 10 bar			
FAUCET OPTIONS				
1	Drilling centering lugs for PN16 or PN25 flanges according to EN 1092-1			
2	Connections with tapped lugs			

INSTALLATION IN ATEX ZONE

If the automatic valve 1115-1116+NA-X is installed in ATEX zones 1 or 2, it is necessary to specify it when ordering. Our services will verify the assembly, install a ground braid and produce an assembly certificate. These operations are carried out in the workshop by our approved technicians. Consult us.

It is also necessary to follow the special assembly and maintenance instructions for motorized valves in ATEX zone.

ATEX cable glands and plugs are not included in the supply. Use the following codes:

Aluminum cable gland M20x1.5 ATEX	Code 980179	Aluminum cap M20x1.5 ATEX	Code 980180
-----------------------------------	-------------	---------------------------	-------------

Information given for information purposes only and subject to possible modifications



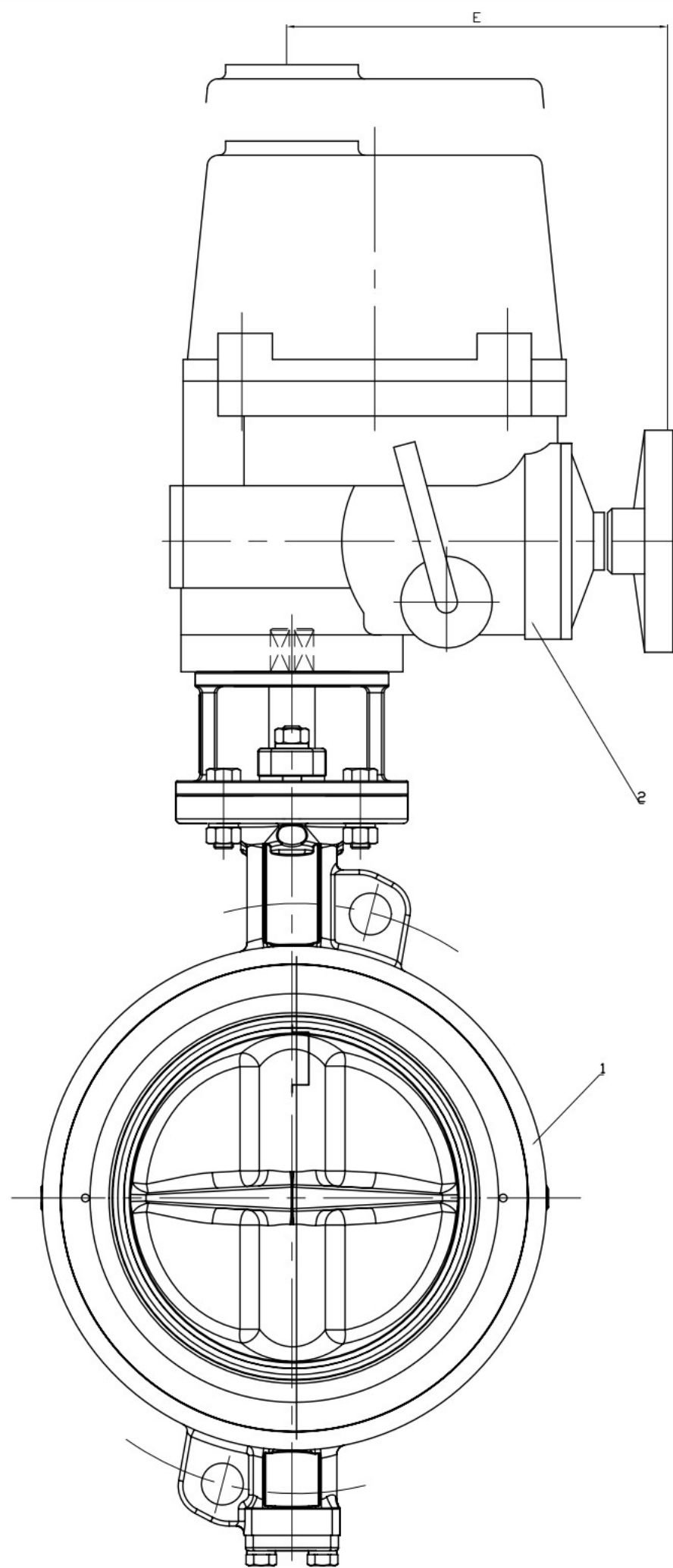
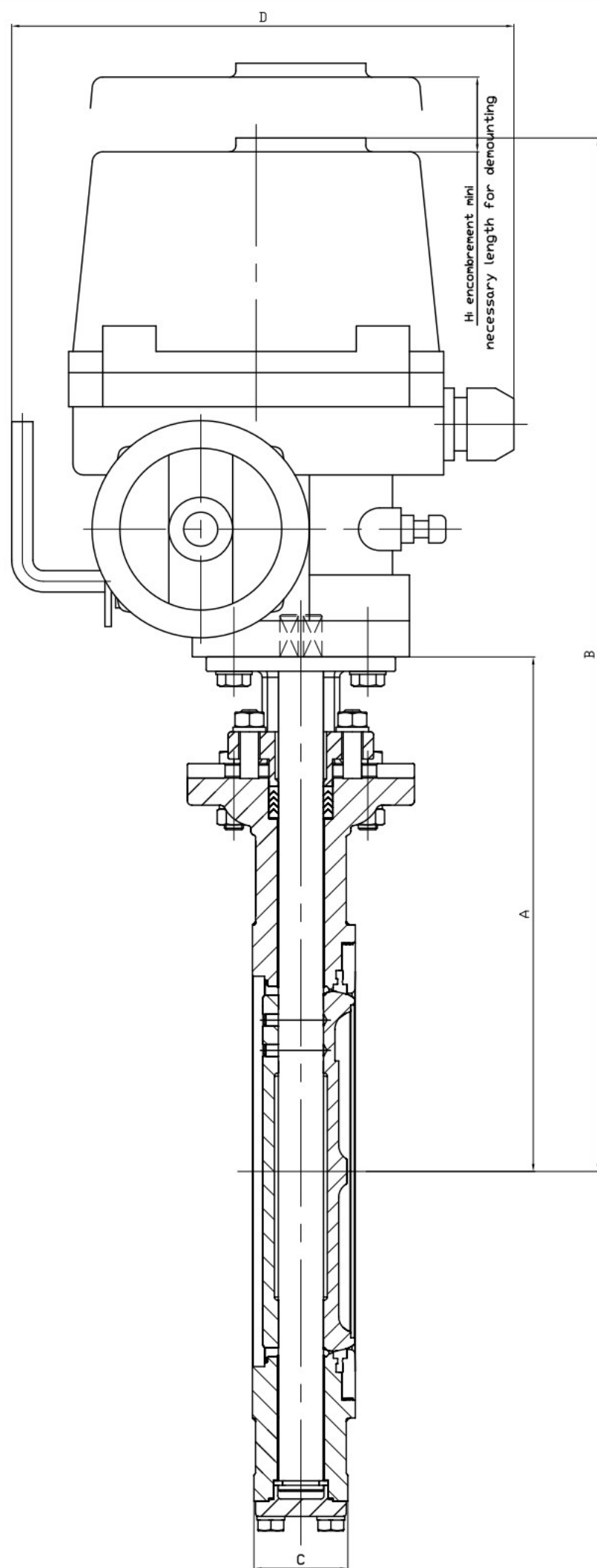

DN	50	65	80	100	125	150	200	250	300
NA-NAX	06	06	06	09	15	28	28	38	38
A	178	185	210	227	240	255	300	340	390
B	433	440	465	482	542	557	682*	642	692
C	43	46	47	53	57	56	62	68	78
D	223	223	223	223	266	300	300	300	300
E	175	175	175	175	184	202	202	202	202
H	108	108	108	108	108	130	130	130	130
Poids Kg	14.9	15.5	18	20	24	30.5	40.5	50	66
1	Robinet à papillon à double excentration								
2	Servomoteur électrique NA-NAX								

* DN200 Montage avec platine supplémentaire H=80mm

ELECTRIC SERVOMOTOR NA / NA-X

MAIN FEATURES

The NA electric actuator is intended for motorizing 1/4 turn valves for industrial use. The maximum operating torque is 2500 Nm. Robust construction with epoxy-coated IP67 aluminum casing, the NA actuator is particularly well suited to motorizing ball and butterfly valves installed in workshops or outdoors. It is equipped with a disengageable manual control and torque limiters (except on NA06 and NA09). Many options available. The NA-X version can be used in explosive atmospheres 1 and 2. It complies with standard EN 15714-2.

AVAILABLE MODELS

NA06: 60 Nm to NA250 : 2500 Nm

Supply voltages : 230 VAC, 400 VAC, 24 VAC, 24 VDC



NA version NA-X version



NA-X version

LIMITS OF USE

Version	N / A	NA-X
Protection sign	IP67	
Ambient temperature	-20°C / +70°C -20°C / +55°C	
Service factor	S2-70%	
Explosive atmospheres	forbidden	Zones 1 and 2



MECHANICAL CHARACTERISTICS

Reducer	treated steel sprockets
Rotation angle	90° +/- 5°
Disengagement	by lever
Emergency command	by steering wheel
Torque limiter	except NA06 and NA09

Servo motor	NA06	NA09	NA15		NA28	NA38	NA60	NA100	NA150	NA200	NA250	
Torque (Nm)	60	90	150		280	380	600	1000	1500	2000	2500	
Maneuvering time (s)	17	17	20		24	24	29	29	87	87	87	
ISO 5211	F07	F07	F07/F10	F10/F12	F10/F12	F12/F14	F12/F14	F14/F16	F14/F16	F14/F16		
Training star	17	17	17		22	27	27	27	36	36	46	

CONSTRUCTION GUIDELINES AND STANDARDS

Machine 2006/42/EC	Connection to tap: ISO 5211
Low voltage 2006/95/CE	Electromagnetic compatibility 2004/108/EC
ATEX 1994/9/CE: ATEX II 2 G EEx d II B T4 – NEMKO 03ATEX1342X (NA-X servomotor only)	

Information given for information purposes only and subject to possible modifications



ELECTRIC SERVOMOTOR NA / NA-X

CONSTRUCTION

1	Position indicator	Polycarbonate
2	Capacitor	
3	Wiring terminal block	
4	Limit switches	
5	Body	Aluminum alloy
6	Base	Aluminum alloy
7	Nut	Steel
8	Dome	Polycarbonate
9	Electric motor	
10	Anti-condensation resistance	
11	Steering wheel	Steel
12	Manual control	Steel
13	Release lever	Steel
14	Worm screw	Steel



ELECTRICAL SPECIFICATIONS

Motor protection	Thermal	Anti-condensation	20W resistor
Limit switches 2 adjustable contacts		Electrical connection NA	2 x PE M20x1.5
Auxiliary contacts	2 adjustable dry contacts	Electrical connection NA-X	2 x PE M20x1.5 ATEX (NOT PROVIDED as an option)

Servo motor	NA06	NA09	NA15	NA28	NA38	NA60	NA100	NA150	NA200	NA250				
Power (W)	15	25	40	40	40	60	90	180	98	180	180			
Tension	380V – 50Hz													
Holding current (A)	0.13	0.18	0.3	0.3	0.3	0.33	0.52	0.73	0.52	0.73	0.73			
Inrush current (A)	0.23	0.36	0.59	0.74	0.78	1.24	1.68	0.78	1.68	1.68	1.68			
Tension	220V – 50Hz													
Holding current (A)	0.45	0.58	0.95	0.95	1.3	1.5	2.15	1.5	2.15	2.15	2.15			
Inrush current (A)	0.63	0.89	1.12	1.37	1.85	2.34	3.4	2.34	3.4	3.4	3.4			
Tension	24V – 50Hz													
Holding current (A)	3.2	4.3	6.5	8.1										
Inrush current (A)	6	8	12	14										
Tension	24V DC													
Holding current (A)	2.2	3.5	4.5	6.5										
Inrush current (A)	4.1	4.1	6.6	13.8										

Information given for information purposes only and subject to possible modifications



ELECTRIC SERVOMOTOR NA / NA-X

DIMENSIONS (mm)

NA 06 to NA 100

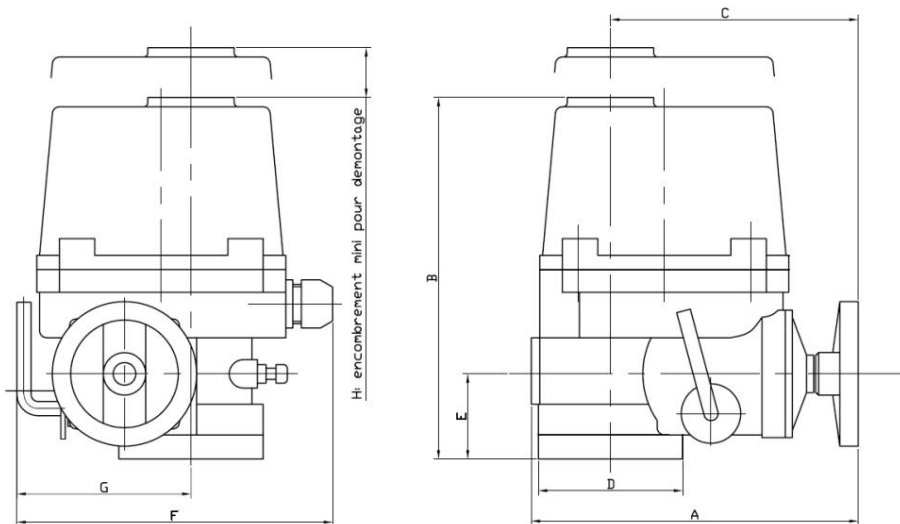

NA 150 to NA 250

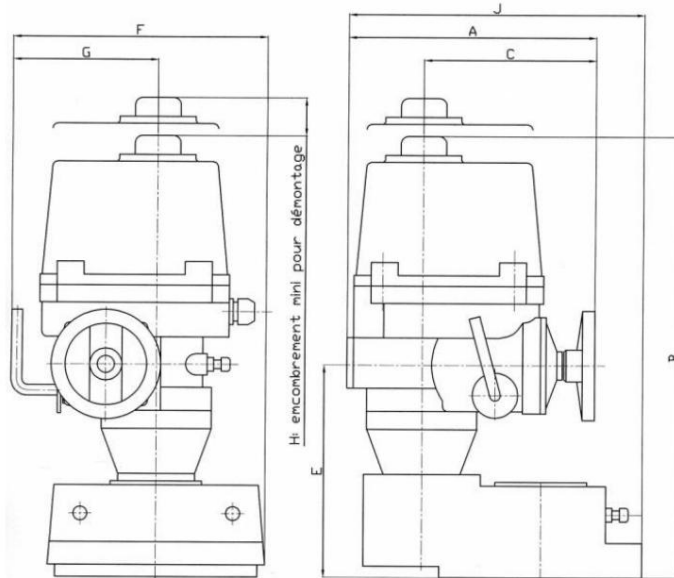

N / A	HAS	B	vs	D	E	F	G	H
06-09	231	255	175	102	60	223	113	108
15	261	255	184	120	60	266	139	108
28-38	285	302	202	145	70	300	159	130
60-100	325	343	226	175	78	349	191	178
150-200-250	325	556	226	-	273	388	191	178

Information given for information purposes only and subject to possible modifications



ELECTRIC SERVOMOTOR NA / NA-X

CABLE SCHEMATICS

Wiring for voltage 230V 50Hz (NA06-NA09)

1	Do not use
2	Do not use
3	Common
4	Phase
5	Closing command
6	Opening command
7	Opening indicator (suggestion)
8	Closing indicator (suggestion)
9	Closing auxiliary
10	Closing auxiliary
11	Opening auxiliary
12	Opening auxiliary

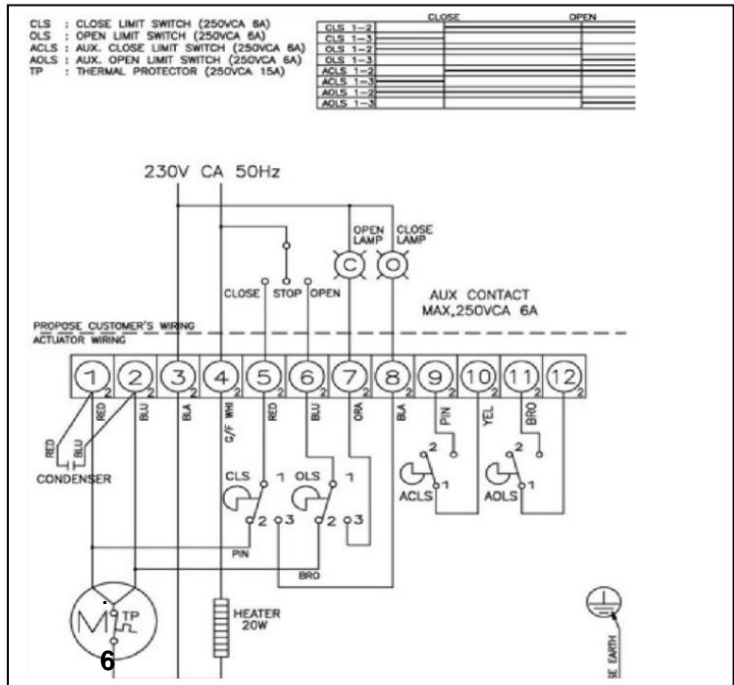

Wiring for voltage 230V 50Hz (other models)

1	Do not use
2	Do not use
3	Common
7	Overload indicator (suggestion)
8	Closing indicator (suggestion)
9	Opening indicator (suggestion)
10	Opening command
11	Closing command
12	phase
13	Closing auxiliary
14	Closing auxiliary
15	Opening auxiliary
16	Opening auxiliary

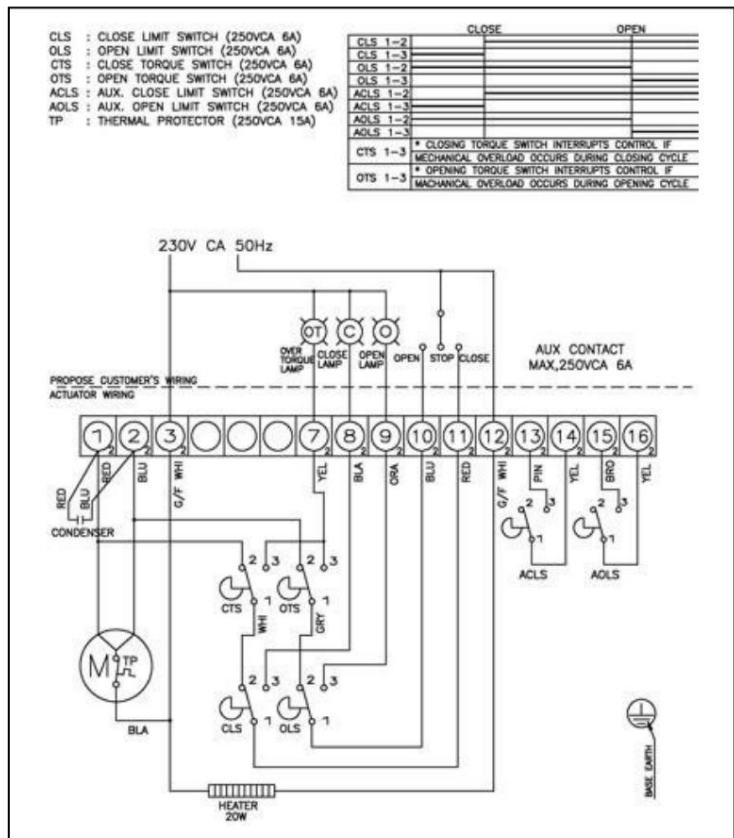

Information given for information purposes only and subject to possible modifications



ELECTRIC SERVOMOTOR NA / NA-X

Wiring for voltage 380V 50HZ (NA06-NA09)

1	Phase U
2	Phase V
3	Phase W
4	Resistance supply
5	Connected to closure 11
6	Connected to opening 10
7	Not used
8	Closing indicator (suggestion)
9	Opening indicator (suggestion)
10	Opening command
11	Closing command
12	Resistance supply
13	Closing auxiliary
14	Closing auxiliary
15	Opening auxiliary
16	Opening auxiliary

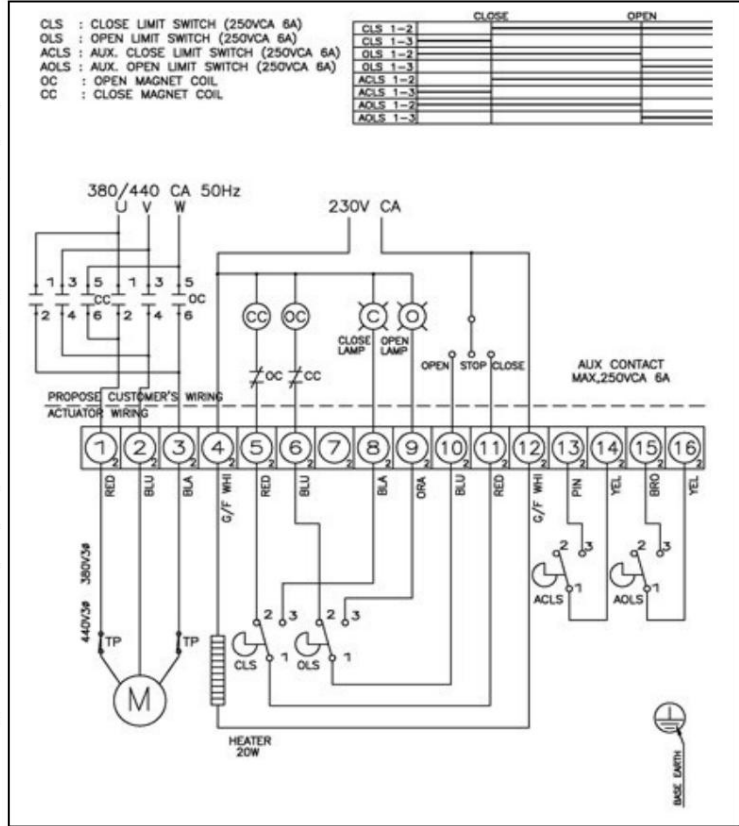

Wiring for voltage 380V 50HZ (other models)

1	Phase U
2	Phase V
3	Phase W
4	Resistance supply
5	Connected to closure 11
6	Connected to opening 10
7	Overload indicator (suggestion)
8	Closing indicator (suggestion)
9	Opening indicator (suggestion)
10	Opening command
11	Closing command
12	Resistance supply
13	Closing auxiliary
14	Closing auxiliary
15	Opening auxiliary
16	Opening auxiliary

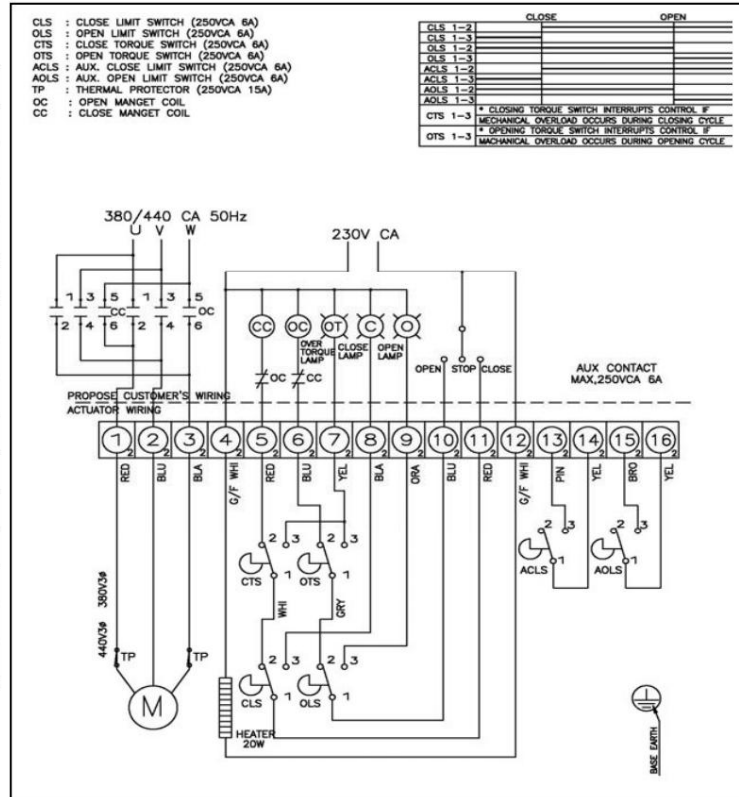

Information given for information purposes only and subject to possible modifications



ELECTRIC SERVOMOTOR NA / NA-X

Wiring for 24V 50HZ voltage (NA06-NA09)

1	Not used
2	Not used
3	Common
4	Phase
5	Closing command
6	Opening command
7	Opening indicator (suggestion)
8	Closing indicator (suggestion)
9	Closing auxiliary
10	Closing auxiliary
11	Opening auxiliary
12	Opening auxiliary

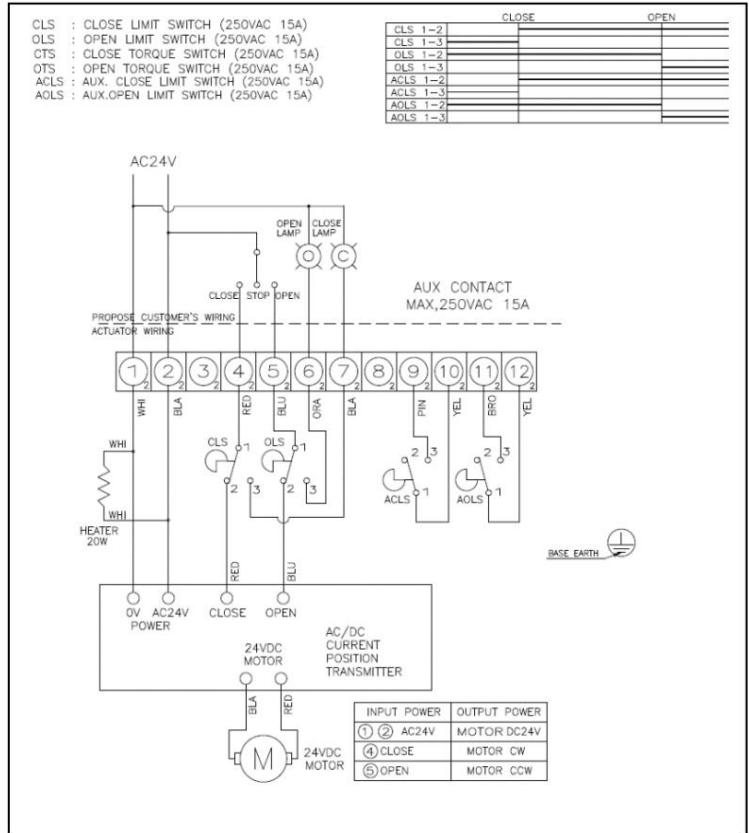

Wiring for 24V 50Hz voltage (other models)

1	Common
2	phase
3	Not used
4	Closing command
5	Opening command
6	Opening indicator (suggestion)
7	Closing indicator (suggestion)
8	Not used
9	Closing auxiliary
10	Closing auxiliary
11	Opening auxiliary
12	Opening auxiliary

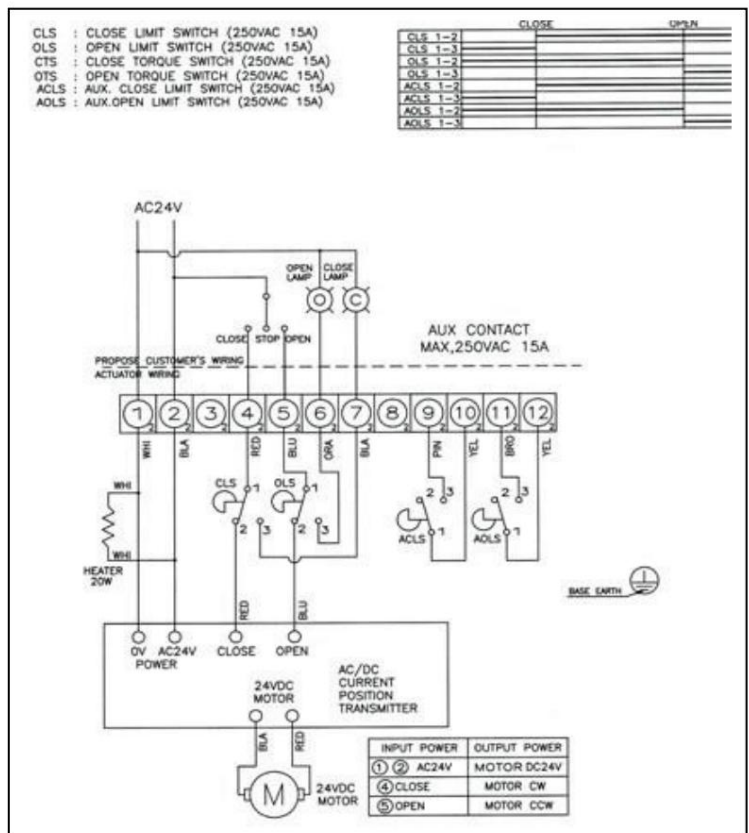

Information given for information purposes only and subject to possible modifications



ELECTRIC SERVOMOTOR NA / NA-X

Wiring suggestions for 24Vdc (NA06-NA09)

1	Connected to terminal 10 with diode
2	Connected to terminal 11 with diode
3	Not used
4	Heating resistance supply
5	Connected to terminal 2
6	Connected to terminal 1
7	Not used
8	Powered closing contact
9	Powered opening contact
10 + / -	Opening command
11 - / +	Closing command
12	Heating resistance supply
13	Closing auxiliary
14	Closing auxiliary
15	Opening auxiliary
16	Opening auxiliary

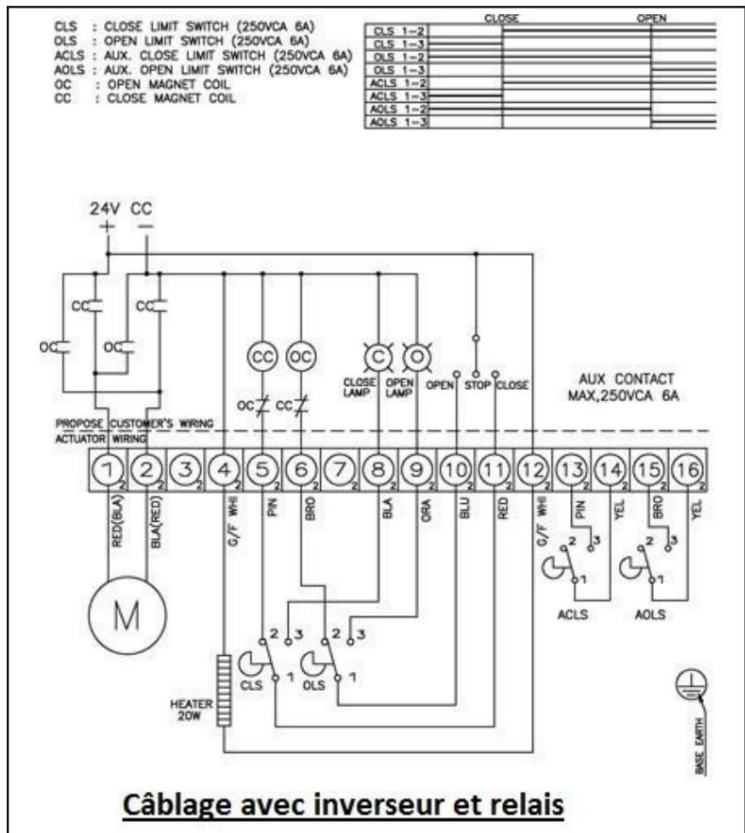
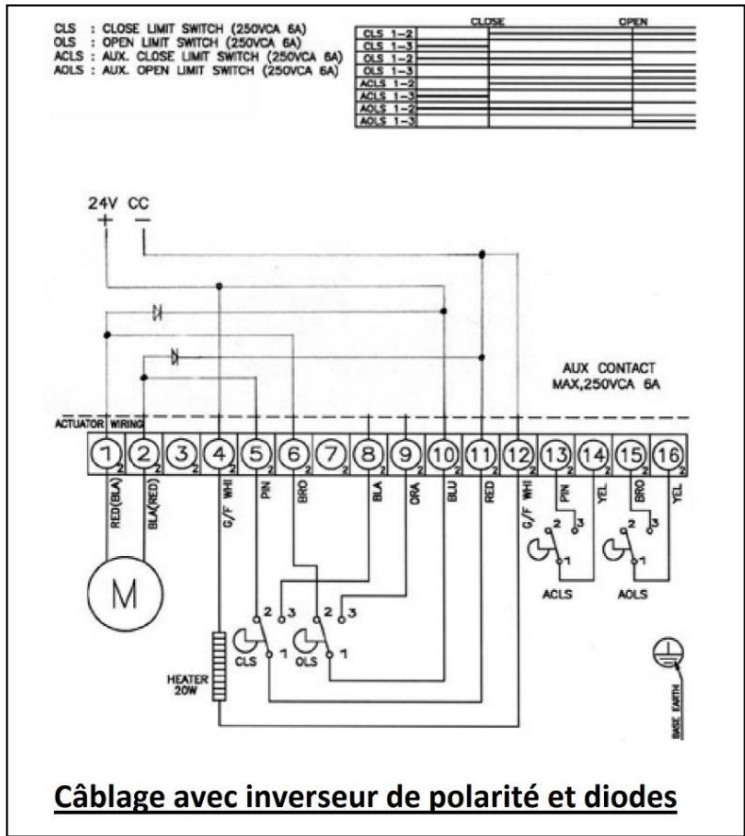

Information given for information purposes only and subject to possible modifications

ELECTRIC SERVOMOTOR NA / NA-X

24VDC wiring suggestions (other models)

1	Connected to terminal 10 with diode
2	Connected to terminal 11 with diode
3	Not used
4	Heating resistance supply
5	Connected to terminal 2
6	Connected to terminal 1
7	Overtorque powered contact
8	Powered closing contact
9	Powered opening contact
10 + / -	Opening command
11 - / +	Closing command
12	Heating resistance supply
13	Closing auxiliary
14	Closing auxiliary
15	Opening auxiliary
16	Opening auxiliary

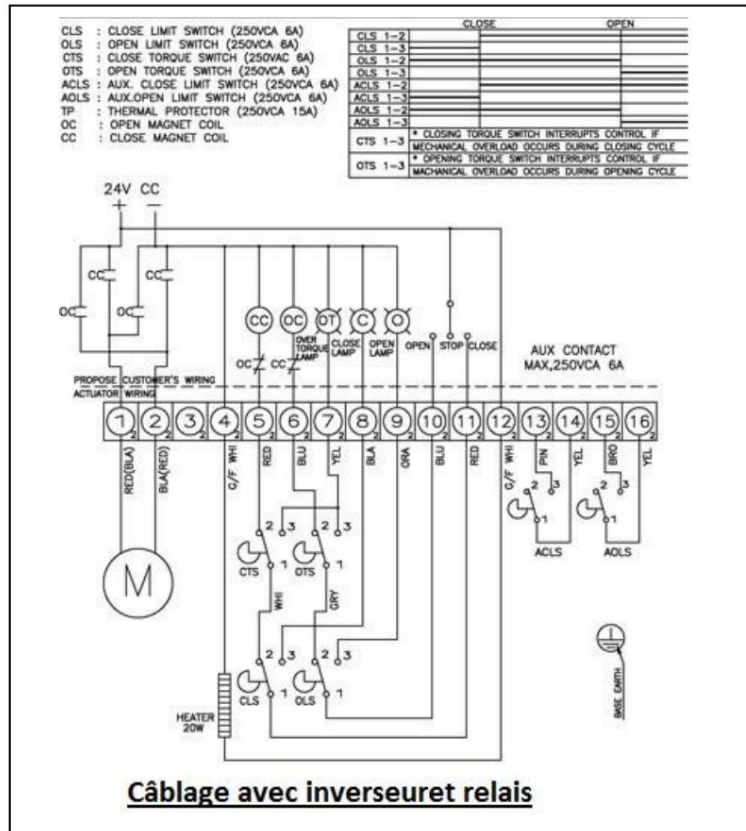
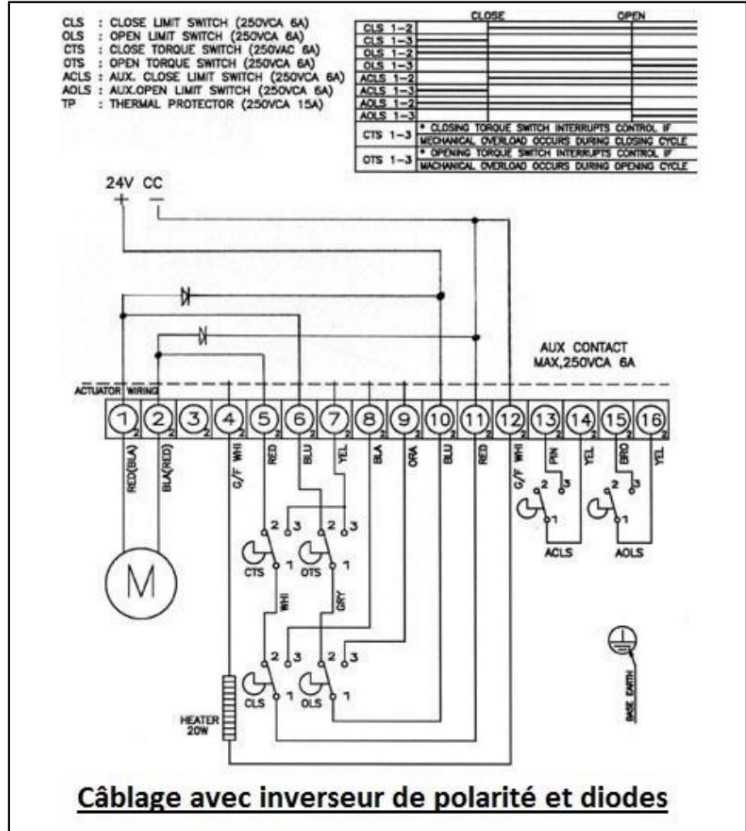

Information given for information purposes only and subject to possible modifications



ELECTRIC SERVOMOTOR NA / NA-X

OPTIONS

1 NA	PIU: version with feedback potentiometer
2 NA	CPT: version with 4-20 mA position transmitter
3 NA	PCU: version with regulation card 0-10V, 2-10V, 2-20 mA, 4-20 mA
4 NA	LCU: version with local control (See below)
5 NA	RBP: version with integrated battery safety block (See below)
6	Anti-seismic test
7	Low temperature version -40°C
8	IP version 68
9	Rotation angles 120° , 135° , 180° , 270°

LCU OPTION: LOCAL CONTROL

The local control option allows the user to choose between two control modes using a switch: classic remote control mode or local mode. In this last mode, the right switch allows you to open and close the tap. This option is particularly useful for maintenance operations and periodic checks.

AVAILABLE MODELS

NA09 LCU : 90 Nm

NA15 LCU : 150 Nm

NA28 LCU : 280 Nm

Supply voltages : 230 Vac, 400 Vac

SPECIFICATION

1	Protection index: IP67
2	Housing: aluminum
3	remote, local, selector switch
4	Open, stop, close selector switch
5	remote, local, opening, torque, closing
6	Padlockable

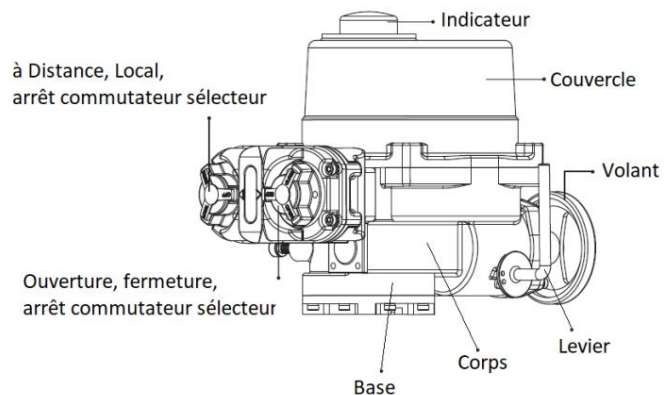

Information given for information purposes only and subject to possible modifications



ELECTRIC SERVOMOTOR NA / NA-X

DIMENSIONS (mm)

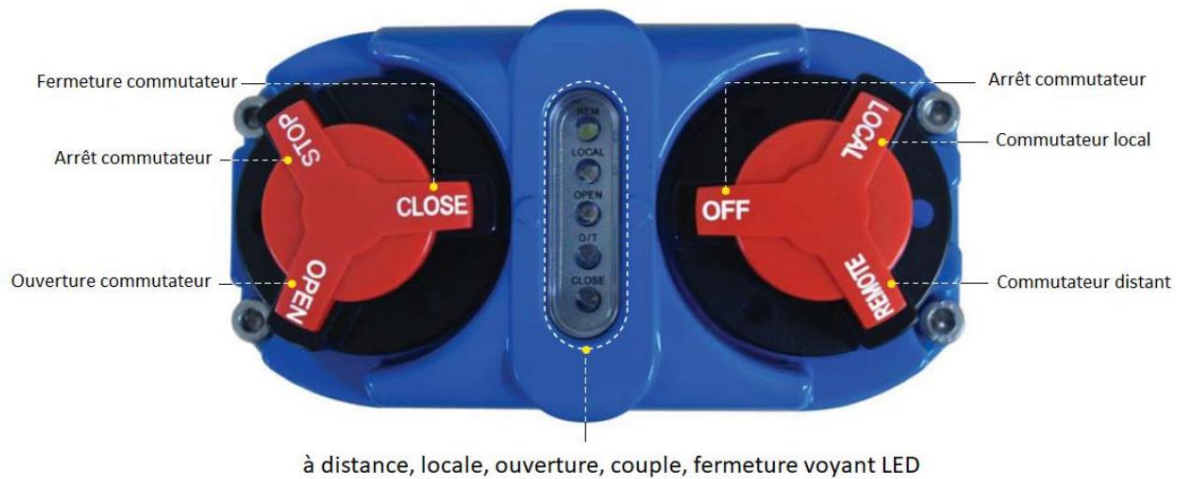
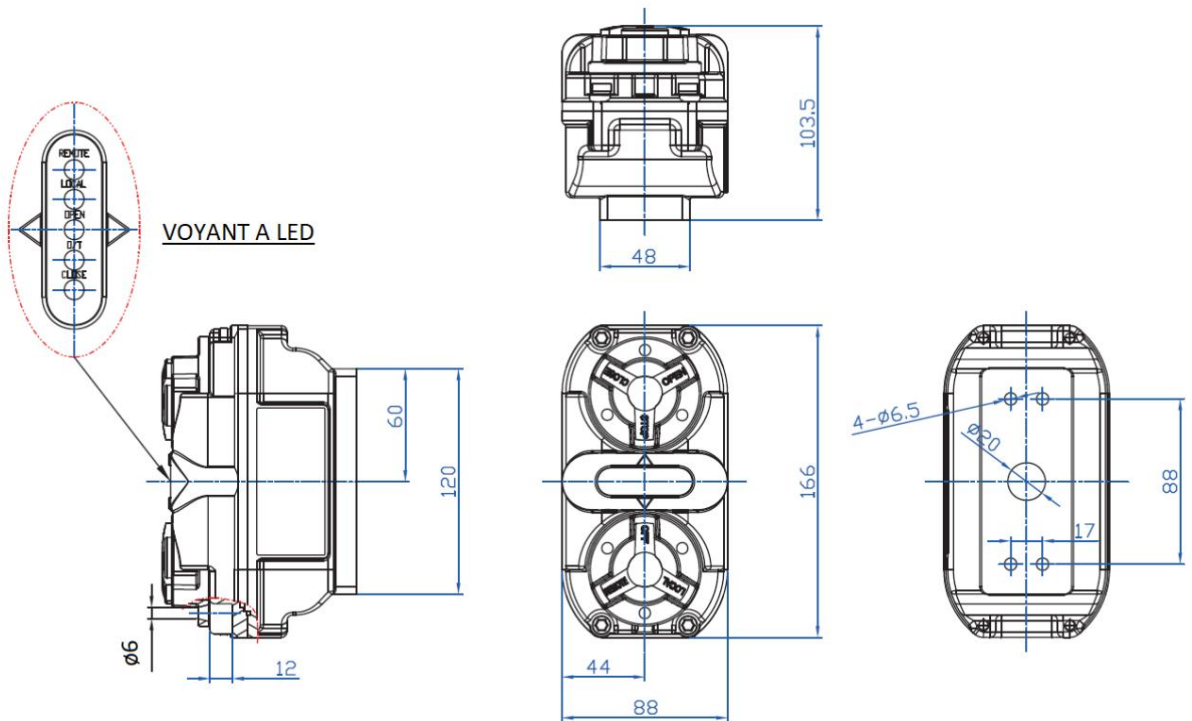

Information given for information purposes only and subject to possible modifications

ELECTRIC SERVOMOTOR NA / NA-X

ELECTRICAL DIAGRAM NA LCU

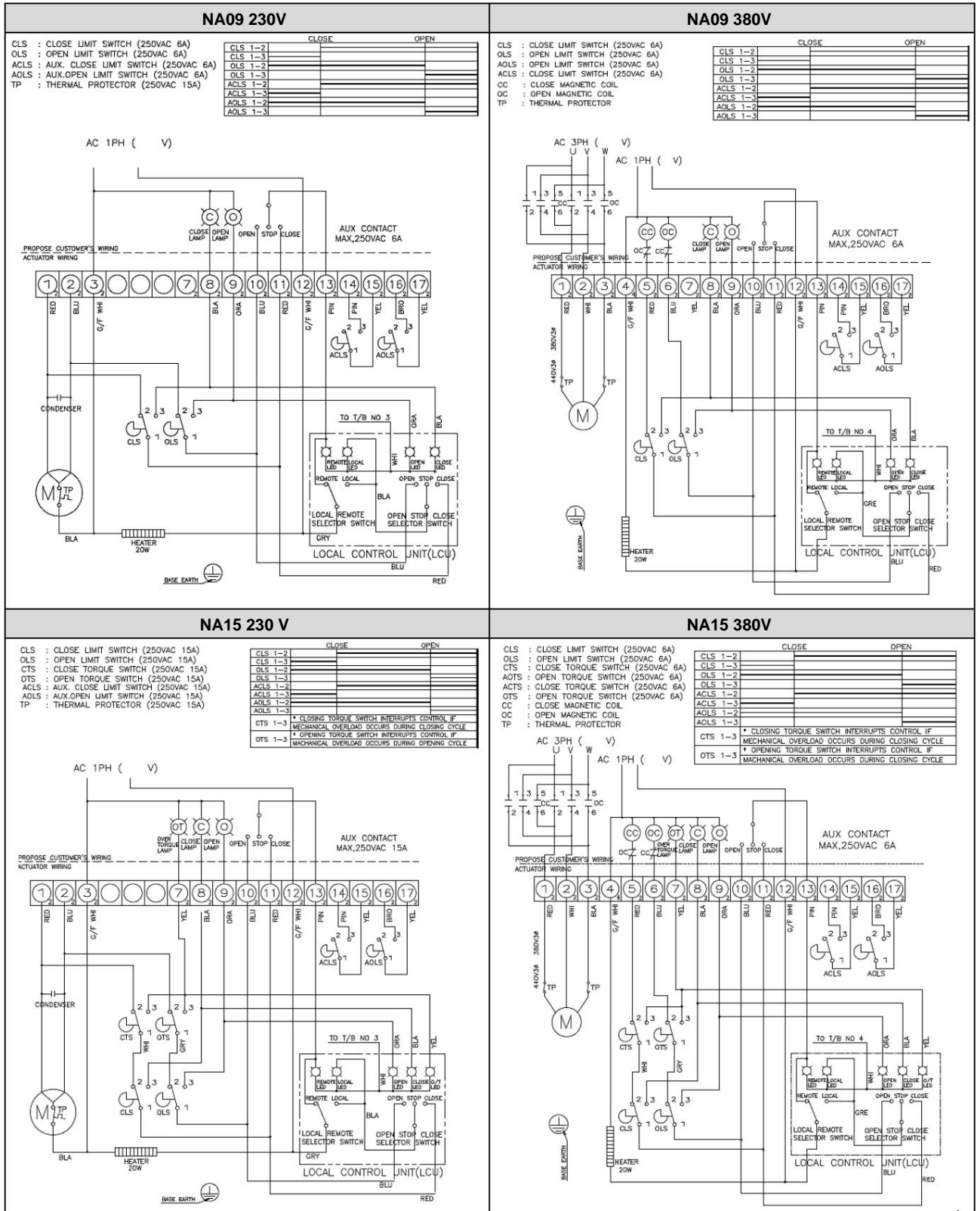

Information given for information purposes only and subject to possible modifications



ELECTRIC SERVOMOTOR NA / NA-X

RBP OPTION: SECURITY

The RBP option adds a safety function to the NA servomotor: in normal operation, maneuvers are ensured by the network power supply. In safety mode (electrical power cut), the actuator automatically performs a maneuver (opening or closing of the valve) to switch the tap to the safety position. Energy is supplied by a battery installed in the side casing.

AVAILABLE MODELS

NA09 RBP : 90 Nm

NA15 RBP : 150 Nm

Supply voltages : 230 Vac



SPECIFICATION

1	<u>Protection index: IP67</u>
2	<u>Housing: aluminum</u>
3	Return to position due to lack of current
4	<u>Power supply: 230V - 50/60Hz</u>
5	Integrated battery safety block
6	Battery size: 89 x 111 x 44 Charging voltage: DC 32V 1A Charging time: 3 hours Battery type: Ni-Cd 1.2V 20EA Engine shutdown time: 15 minutes (Max) Battery weight: 1,1 kg

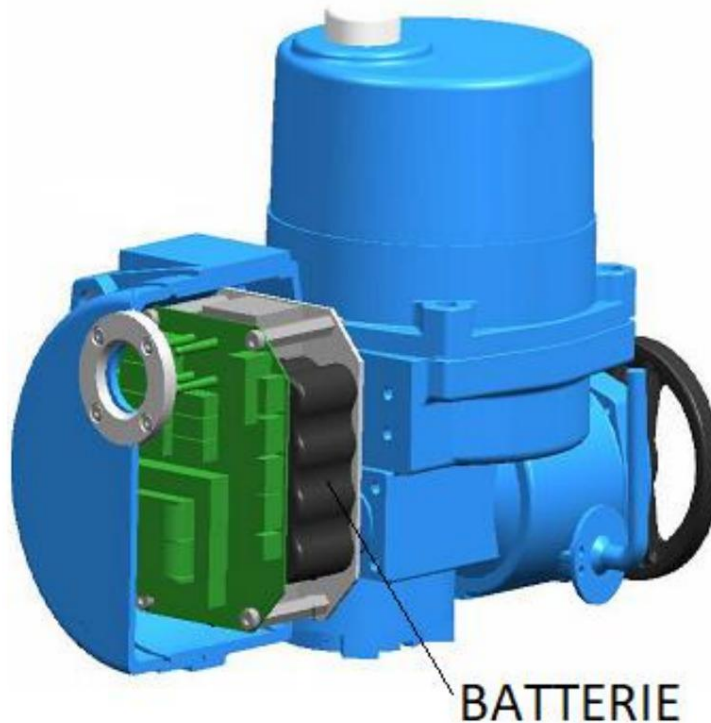

Information given for information purposes only and subject to possible modifications

ELECTRIC SERVOMOTOR NA / NA-X

DIMENSIONS (mm)

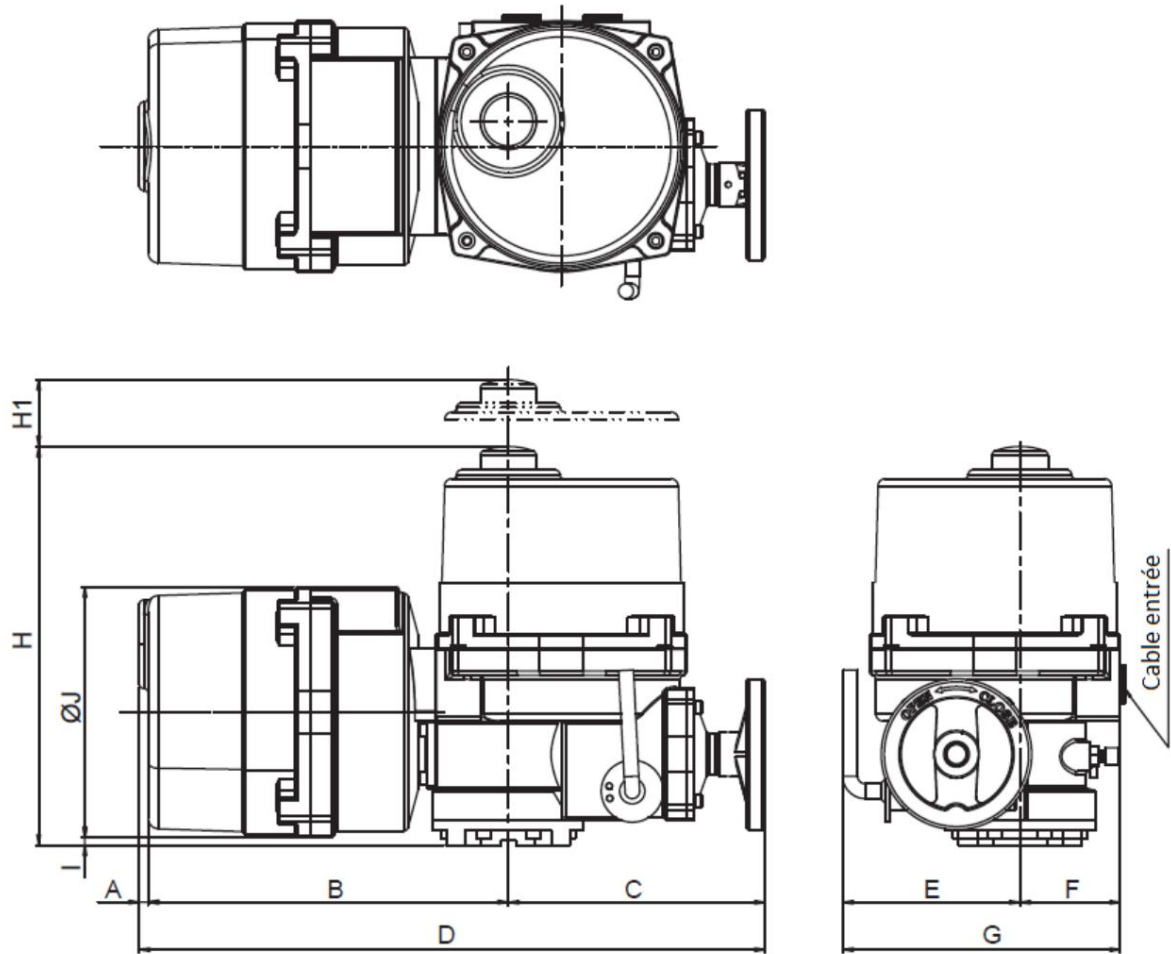

Rep	HAS	B	VS	D	E	F	G	H	H1	ØJ
NA 09	6	244	174	424	120	68	188	270	108	170
NA 15	6	265	184	455	139	85	224	274	108	170

Information given for information purposes only and subject to possible modifications



ELECTRIC SERVOMOTOR NA / NA-X

ELECTRICAL DIAGRAM NA RBP

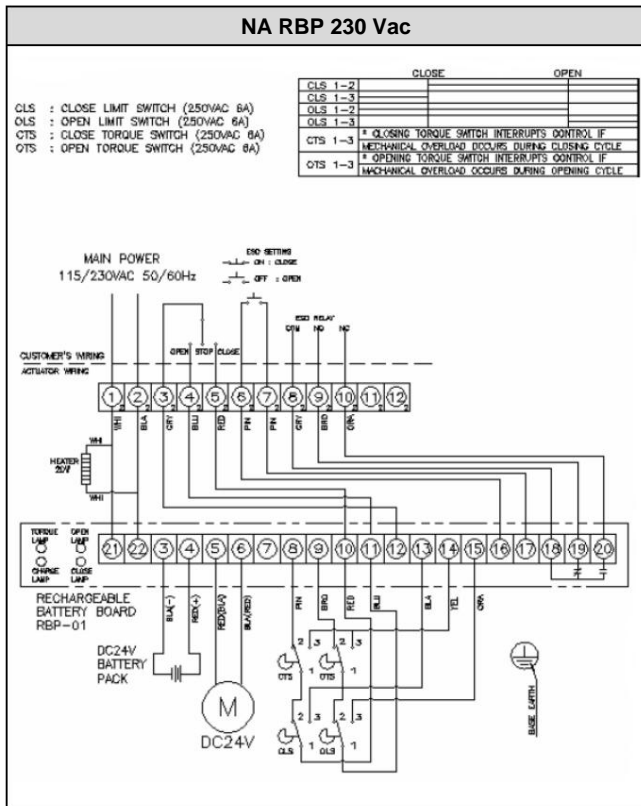

Information given for information purposes only and subject to possible modifications