

CAST IRON AXIAL DISC CHECK VALVE EPDM WITH SPRING FLANGED PN16 ACS

Cast iron axial disc check valve for drinking water, heating and water distribution.
Cast iron EN GJL-250 body coated with anti-corrosion epoxy painting, ductile iron disc and EPDM seat.
All positions thanks to the stainless steel spring.



Certificate

3.1



Size : DN50 to DN600
Connection : Between flanges PN10/16 RF
Min Temperature : -10°C
Max Temperature : +120°C
Max Pressure : 16 Bars up to DN300 (10 bars over)
Specifications : Disc type
All positions
Stainless steel spring
Epoxy painting
Weak headloss

Materials : Cast iron EN GJL-250 body or ductile EN GJS-400-15

CAST IRON AXIAL DISC CHECK VALVE EPDM WITH SPRING FLANGED PN16 ACS

SPECIFICATIONS :

- All positions thanks to the stainless steel spring
- Respect the flow direction indicated by an arrow on the body
- Flanges R.F. PN10/16 up to DN150, PN16 from DN200 to DN300, PN10 over
- Weak head loss thanks to the cylindrical internal designing
- Anti-corrosion epoxy internal and external painting blue color RAL 5017, 100 μ thickness
- Bronze bushing to avoid blocking of the disc
- Drilled boss on request for bypass or to check the thickness
- Disc designed for a better hydrodynamism
- Silent solution
- Minimum back pressure for tightness : 0.2 bars

USE :

- Water distribution
- Min Temperature Ts : - 10°C
- Max Temperature Ts : + 120°C
- Max Pressure Ps : 16 bars up to DN300, 10 bars over

HEAD LOSS GRAPH :

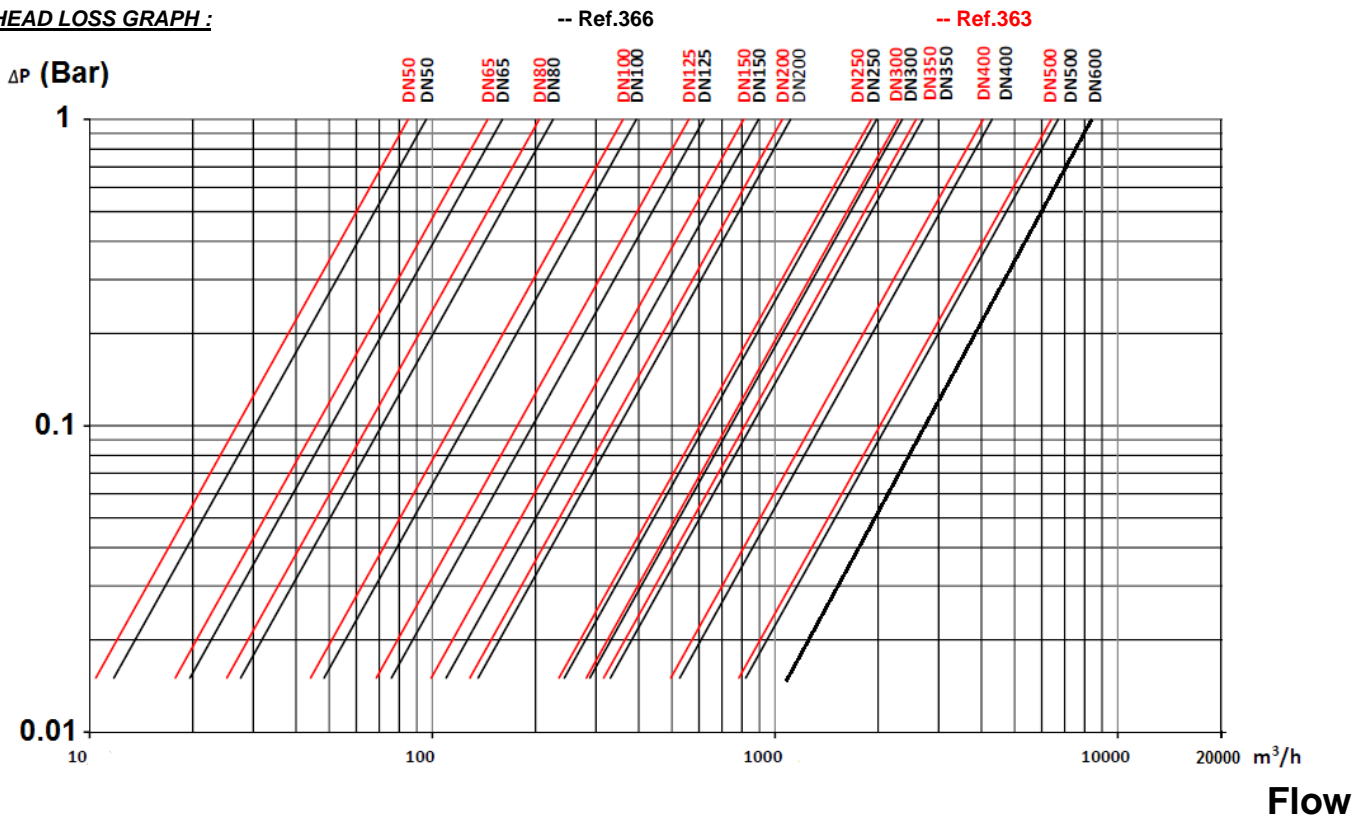

FLOW COEFFICIENT Kvs (in m3/h) :

DN	50	65	80	100	125	150	200	250	300	350	400	500	600
Kvs (m3/h)	96	160	225	394	620	895	1110	1980	2350	2700	4300	6300	8400

CAST IRON AXIAL DISC CHECK VALVE EPDM WITH SPRING FLANGED PN16 ACS
RANGE :

- Disc check valve flanged PN10/16 from DN50 to DN 150, PN16 from DN 200 to DN 300 and PN10 for DN350 to 600 **Ref. 366**

OPENING PRESSURE (mbar) :

DN	Vertical Position ascending fluid	Horizontal Position
DN 50	55 ↑	40 →
DN 65	52 ↑	35 →
DN 80	52 ↑	34 →
DN 100	53 ↑	35 →
DN 125	65 ↑	46 →
DN 150	66 ↑	48 →
DN 200	76 ↑	55 →
DN 250	91 ↑	62 →
DN 300	90 ↑	58 →
DN 350	91 ↑	59 →
DN 400	106 ↑	70 →
DN 500	114 ↑	72 →
DN 600	155 ↑	92 →

CAST IRON AXIAL DISC CHECK VALVE EPDM WITH SPRING FLANGED PN16 ACS

MATERIALS DN 50 - 100 :

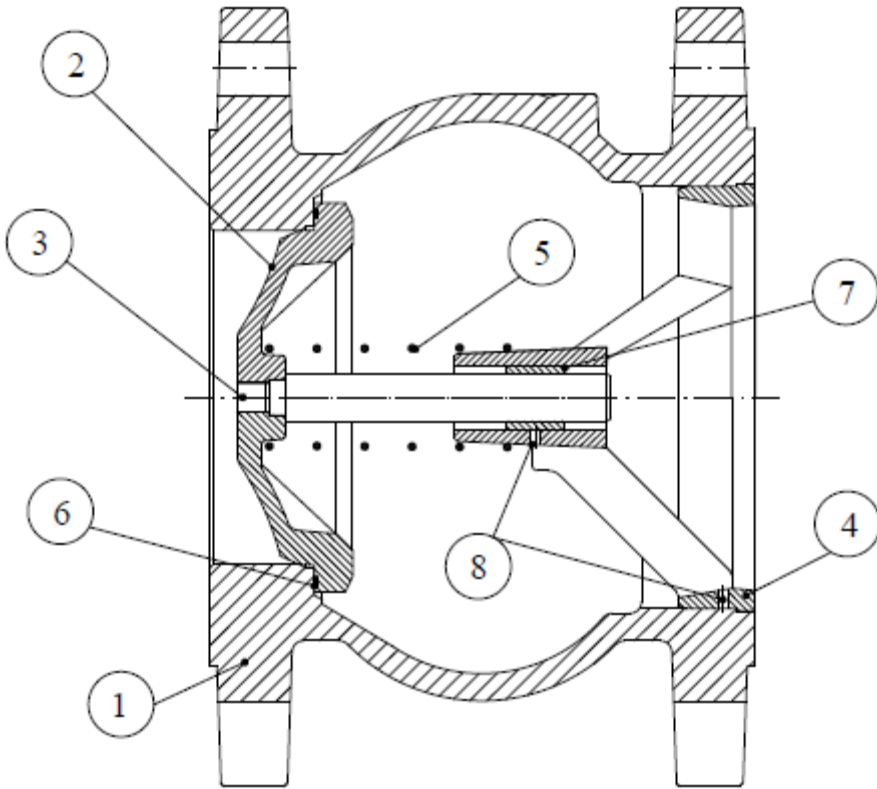

Item	Designation	Materials
1	Body	Cast iron EN-GJL-250
2	Disc	Ductile iron EN-GJS-400-15
3	Stem	AISI 304L
4	Guide	Ductile iron EN-GJS-400-15
5	Spring	AISI 302
6	Gasket	EPDM
7	Bushing	Bronze
8	Pin	AISI 304

CAST IRON AXIAL DISC CHECK VALVE EPDM WITH SPRING FLANGED PN16 ACS

MATERIALS DN 125 - 300 :

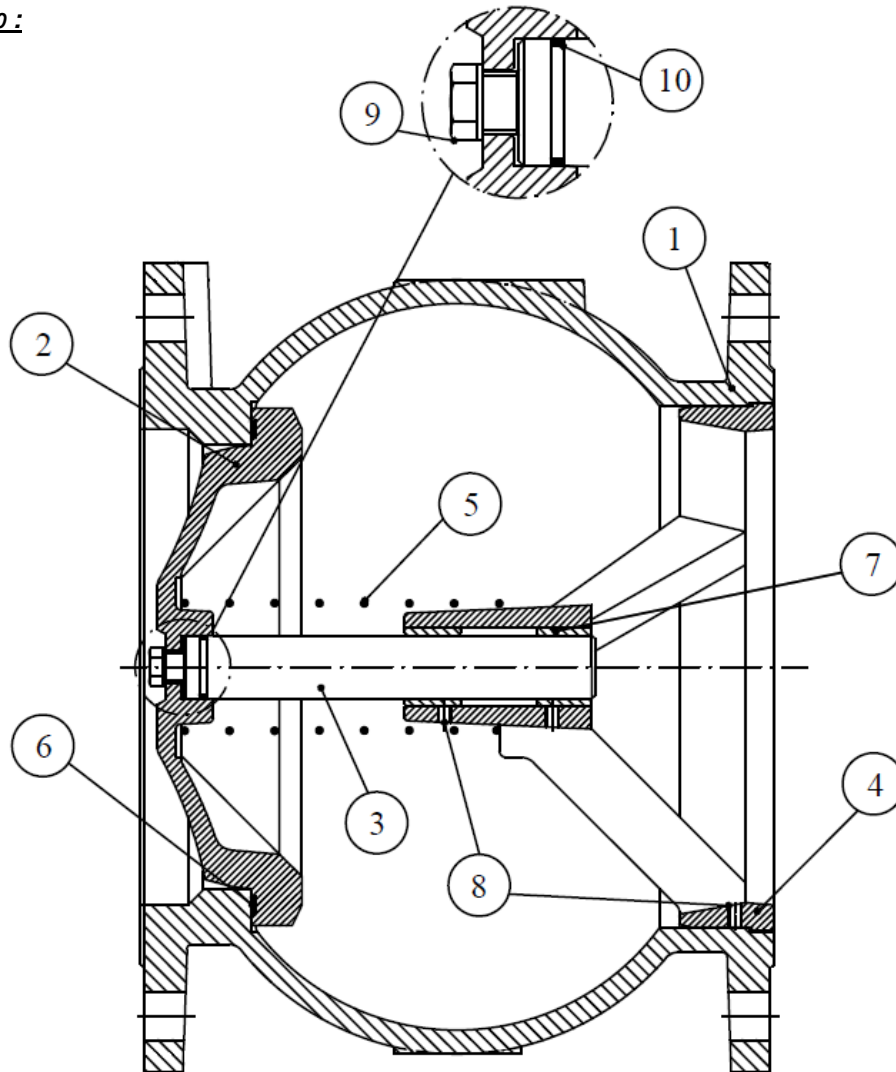

Item	Designation	Materials DN125-200	Materials DN250-300
1	Body	Cast iron EN-GJL-250	Ductile iron EN-GJS-400-15
2	Disc	Ductile iron EN-GJS-400-15	Ductile iron EN-GJS-400-15
3	Stem	AISI 304L	AISI 304
4	Guide	Ductile iron EN-GJS-400-15	Ductile iron EN-GJS-400-15
5	Spring	AISI 302	AISI 302
6	Gasket	EPDM	EPDM
7	Bushing	Bronze	Bronze
8	Pin	AISI 304	AISI 304
9	Nut	AISI 304	AISI 304
10	O ring	EPDM	EPDM

CAST IRON AXIAL DISC CHECK VALVE EPDM WITH SPRING FLANGED PN16 ACS

MATERIALS DN 350 -400 :

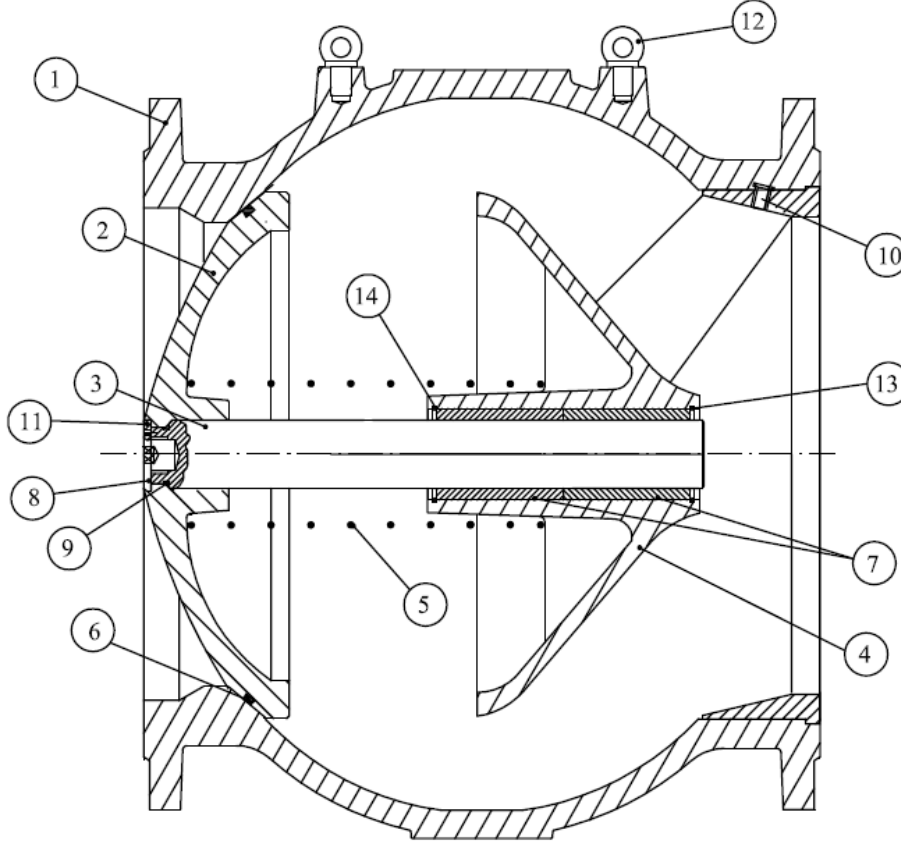

Item	Designation	Materials DN350	Materials DN400
1	Body	Ductile iron EN-GJS-400-15	Ductile iron EN-GJS-400-15
2	Disc	Ductile iron EN-GJS-400-15	Ductile iron EN-GJS-400-15
3	Stem	AIS 304L	AISI 316
4	Guide	Ductile iron EN-GJS-400-15	Ductile iron EN-GJS-400-15
5	Spring	AISI 302	AISI 302
6	Gasket	EPDM	EPDM
7	Bushing	Bronze	Bronze
8	Cap	AISI 304L	Steel
9	O ring	EPDM	EPDM
10	Screw	A4	AISI 304
11	Screw	A4	AISI 304
12	Lifting plug	Steel	Steel
13-14	Circlip	-	AISI 302

CAST IRON AXIAL DISC CHECK VALVE EPDM WITH SPRING FLANGED PN16 ACS

MATERIALS DN 450 -600 :

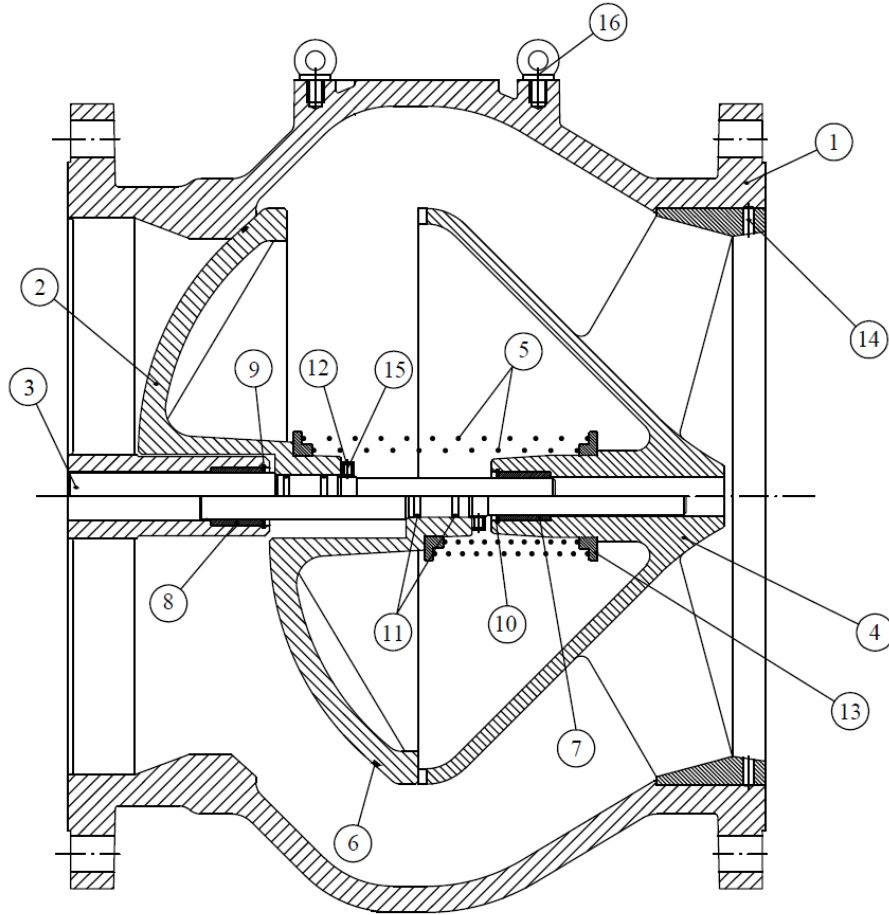

Item	Designation	Materials
1	Body	Ductile iron EN-GJS-400-15
2	Disc	Ductile iron EN-GJS-400-15
3	Stem	AISI 304L
4	Guide	Ductile iron EN-GJS-400-15
5	Spring	AISI 302
6	Gasket	EPDM
7-8	Bushing	Bronze
9-10	Circlip	AISI 302
11	O ring	EPDM
12	Nut	AISI 304L
13	Washer	AISI 304L
14-15	Screw	A4
16	Lifting plug	Steel

CAST IRON AXIAL DISC CHECK VALVE EPDM WITH SPRING FLANGED PN16 ACS

SIZE REF.366 DN 50 - 300 (in mm) :

DN50 – 100

DN125 - 300

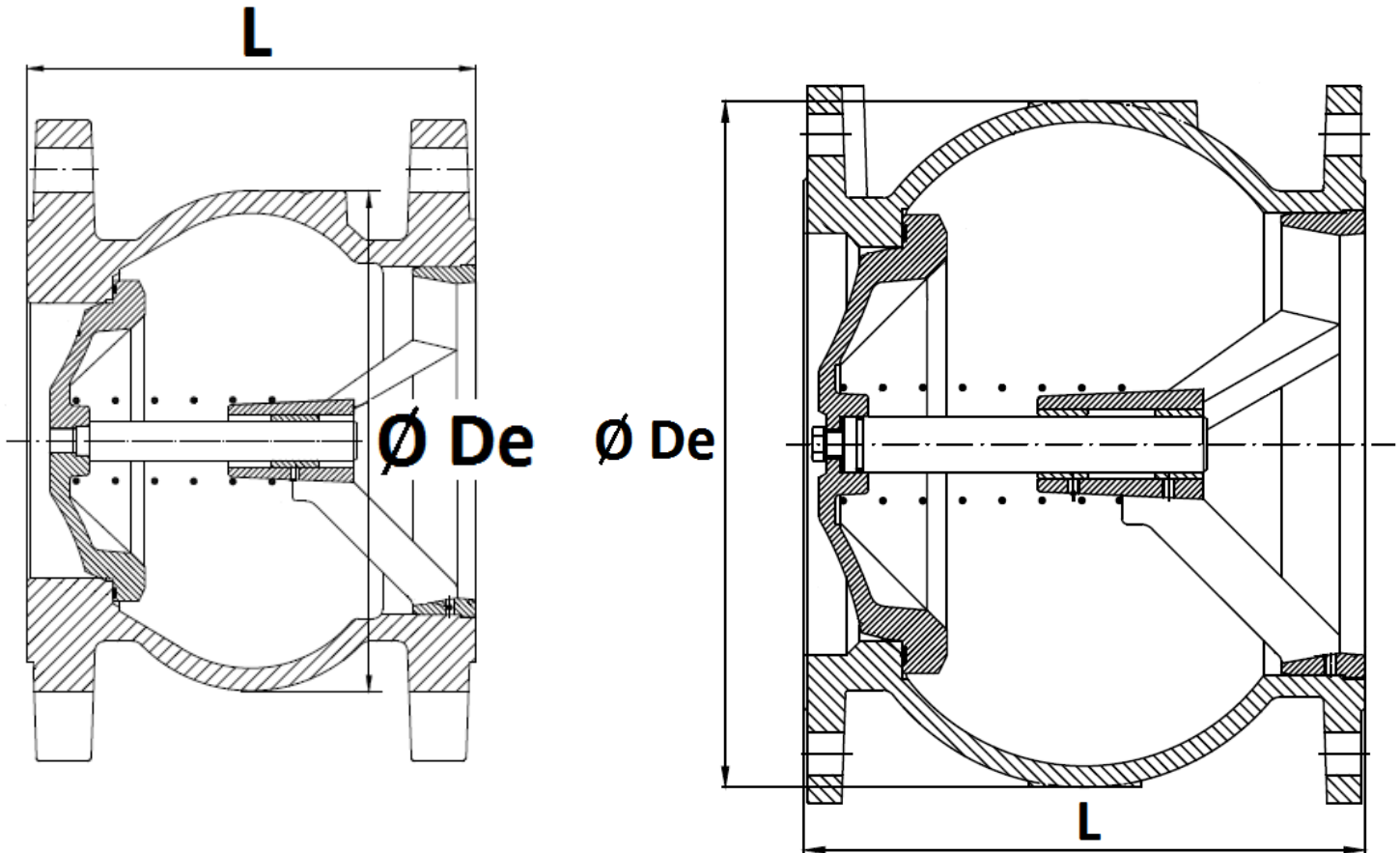

DN	50	65	80	100	125	150	200	250	300
L	105	120	140	165	195	230	290	355	400
Ø De	104	127	157	180	215	250	335	410	486
Weight (Kg)	5.42	8.22	10.13	13.53	19.5	27.07	46.8	77.2	128
Ref.	366050	366065	366080	366100	366125	366150	366200	366250	366300

CAST IRON AXIAL DISC CHECK VALVE EPDM WITH SPRING FLANGED PN16 ACS

SIZE REF. 366 DN 350 – 600 (in mm) :

DN350 – 400

DN450 - 600

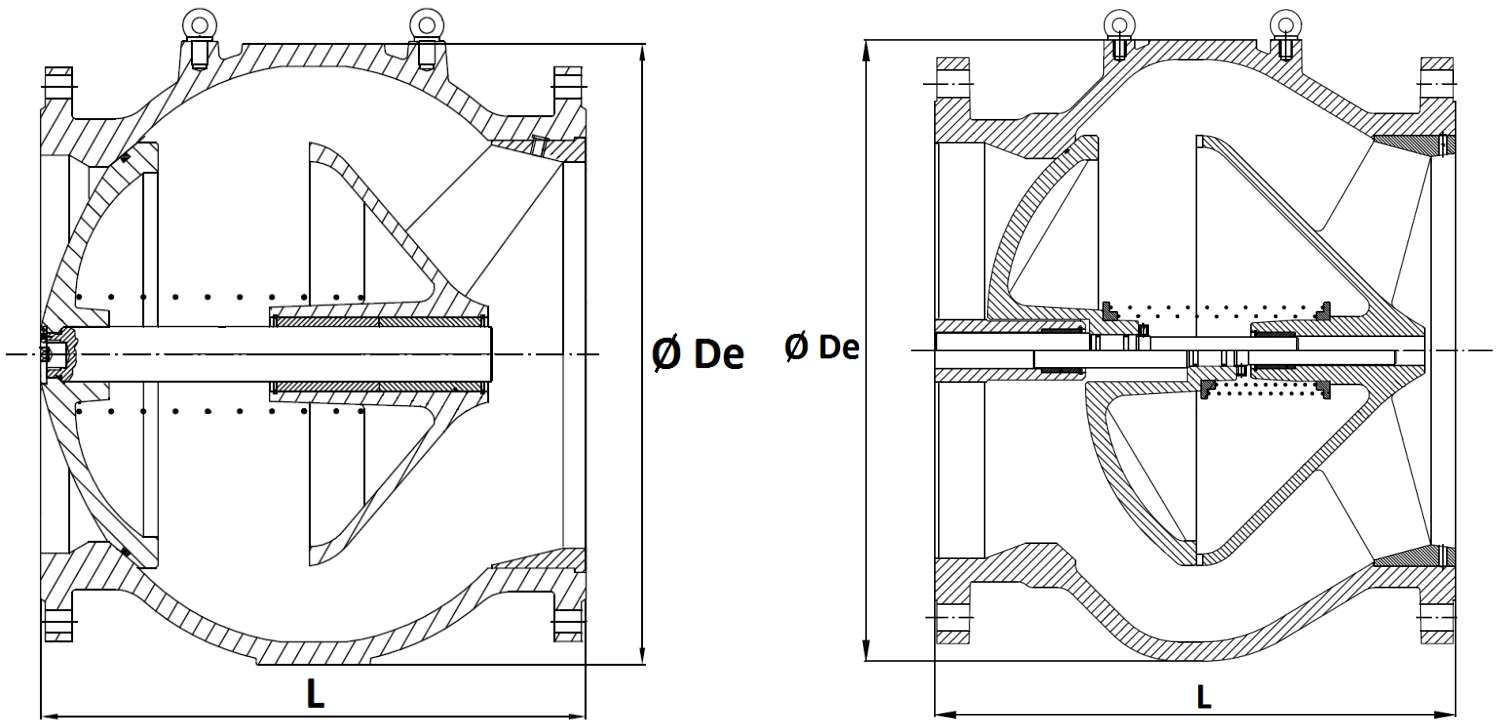

DN	350	400	500	600
L	480	550	670	750
Ø De	550	620	750	885
Weight (in Kg)	185	260	480	630
Ref.	366350	366400	366500	366600

CAST IRON AXIAL DISC CHECK VALVE EPDM WITH SPRING FLANGED PN16 ACS

FLANGES SIZE (in mm) :

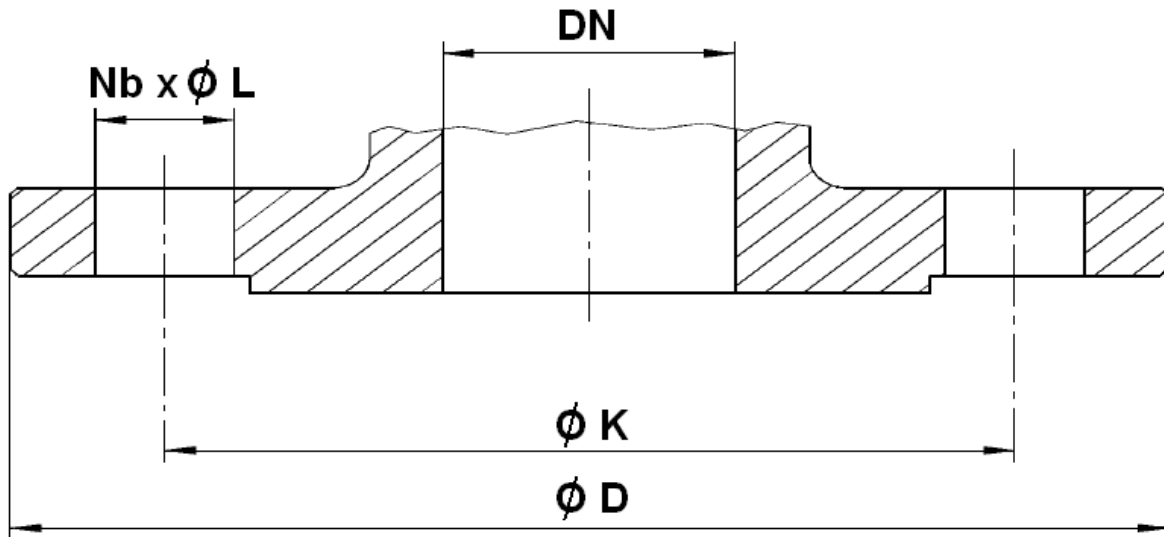

DN	50	65	80	100	125	150	200	250	300	350	400	500	600
Ø D	165	185	200	220	250	285	340	405	460	505	565	670	780
Ø K	125	145	160	180	210	240	295	355	410	460	515	620	725
Nb x Ø L	4 x 19	4 x 19	8 x 19	8 x 19	8 x 19	8 x 23	12 x 23	12 x 28	12 x 28	16 x 23	16 x 27	20 x 26	20 x 30

STANDARDS :

- Manufacturer certified ISO 9001: 2015 and ISO 14001 : 2015
- DIRECTIVE 2014/68/EU : Products excluded from directive (Article 1, § 2b)
- Certificate 3.1 on request
- French water agreement **A.C.S. N° 20 ACC LY 724**
- Pressure Tests according to ISO 5208, Rate A
- Flanges according to EN 1092-2 PN10-PN16

ADVICE : Our opinion and our advice are not guaranteed and SFERACO shall not be liable for the consequences of damages. The customer must check the right choice of the products with the real service conditions.