

CAST IRON AXIAL DISC FOOT TYPE CHECK VALVE EPDM FLANGED PN16

Cast iron axial disc foot type check valve with galvanized carbon steel strainer for heating and water distribution.
Cast iron EN GJL-250 body coated with anti-corrosion epoxy painting, stainless steel disc and EPDM seat.
Vertical position.

Certificate

3.1



Size : DN50 to DN250
Connection : Between flanges PN16 RF
Min Temperature : -10°C
Max Temperature : +110°C
Max Pressure : 16 Bars
Specifications : Stainless steel disc
Vertical position
Stainless steel spring
Epoxy painting
Weak headloss

Materials : Cast iron EN GJL-250 body

CAST IRON AXIAL DISC FOOT TYPE CHECK VALVE EPDM FLANGED PN16

SPECIFICATIONS :

- Vertical position
- Respect the flow direction indicated by the arrow
- Flanged R.F. PN16
- Stainless steel disc with spring
- Opening pressure about 0.3 bar
- Epoxy blue RAL 5005 painting 80 microns thickness
- Galvanized carbon steel strainer

USE :

- Water distribution
- Min Temperature Ts : - 10°C
- Max Temperature Ts :+ 110°C
- Max Pressure Ps : 16 bars

RANGE :

- Foot valve flanged PN16 from DN50 to DN250 **Ref.368**

CAST IRON AXIAL DISC FOOT TYPE CHECK VALVE EPDM FLANGED PN16

MATERIALS :

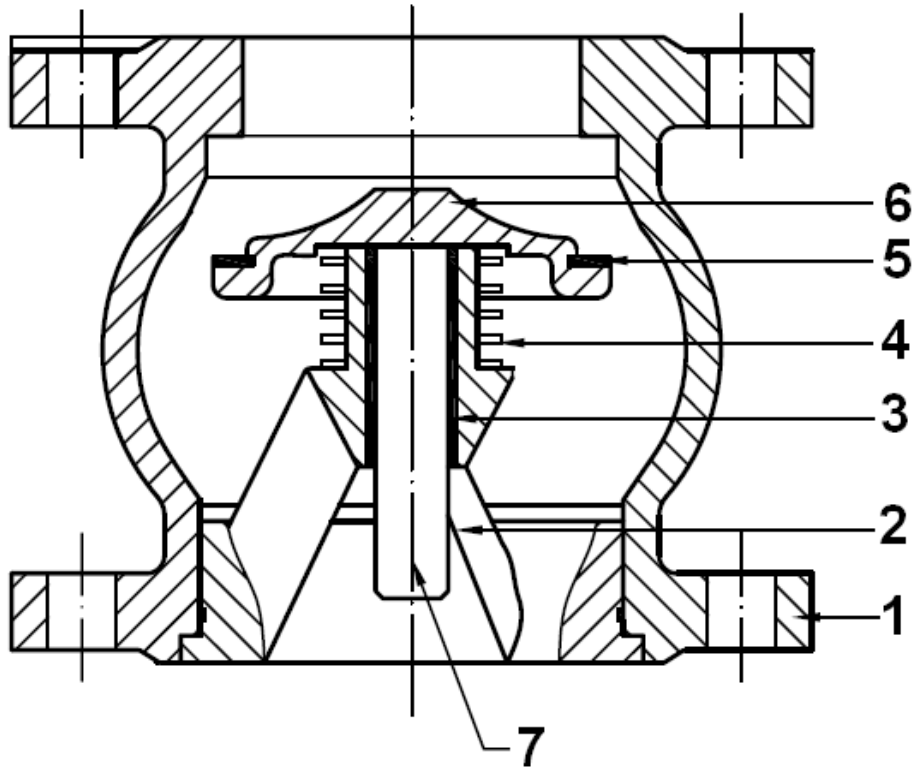

Item	Designation	Materials
1	Body	Cast iron EN-GJL-250
2	Guide	
3	Bushing	Bronze
4	Spring	AISI 304
5	Gasket	EPDM
6	Disc	AISI 304
7	Shaft	AISI 416
	Strainer	Galvanized carbon steel

CAST IRON AXIAL DISC FOOT TYPE CHECK VALVE EPDM FLANGED PN16

SIZE (in mm) :

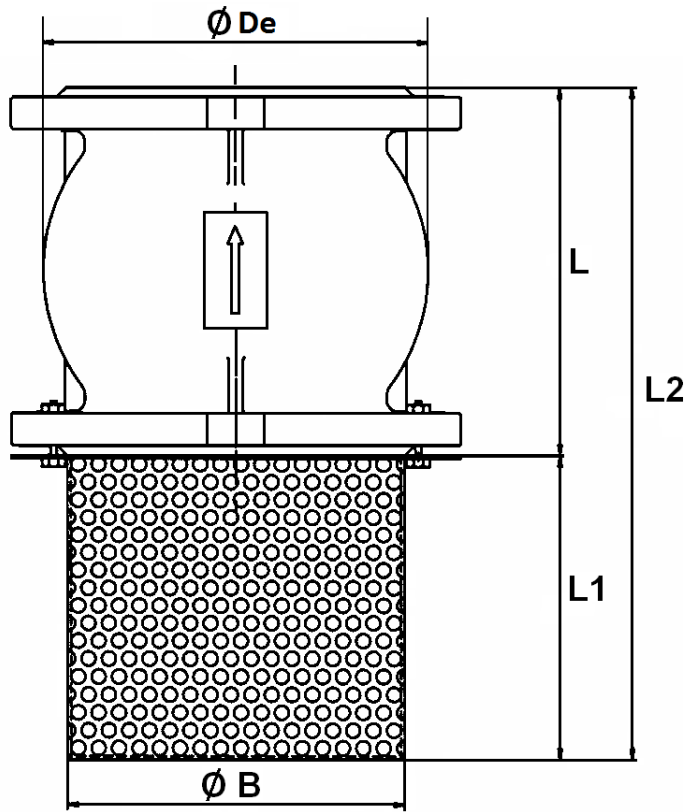

DN	50	65	80	100	125	150	200	250
L	100	120	135	165	200	231	288	354
L1	77	110	125	155	170	220	300	390
L2	177	230	260	320	370	451	588	744
Ø De	104	135	160	194	233	269	338	429
Ø B	93	113	128	148	178	200	255	310
Mesh	6	6	6	6	6	6	6	6
Weight (Kg)	6.59	9.76	11.83	16.7	24.99	36.3	59.28	101.88
Ref.	368050	368065	368080	368100	368125	368150	368200	368250

CAST IRON AXIAL DISC FOOT TYPE CHECK VALVE EPDM FLANGED PN16

FLANGES SIZE (in mm) :

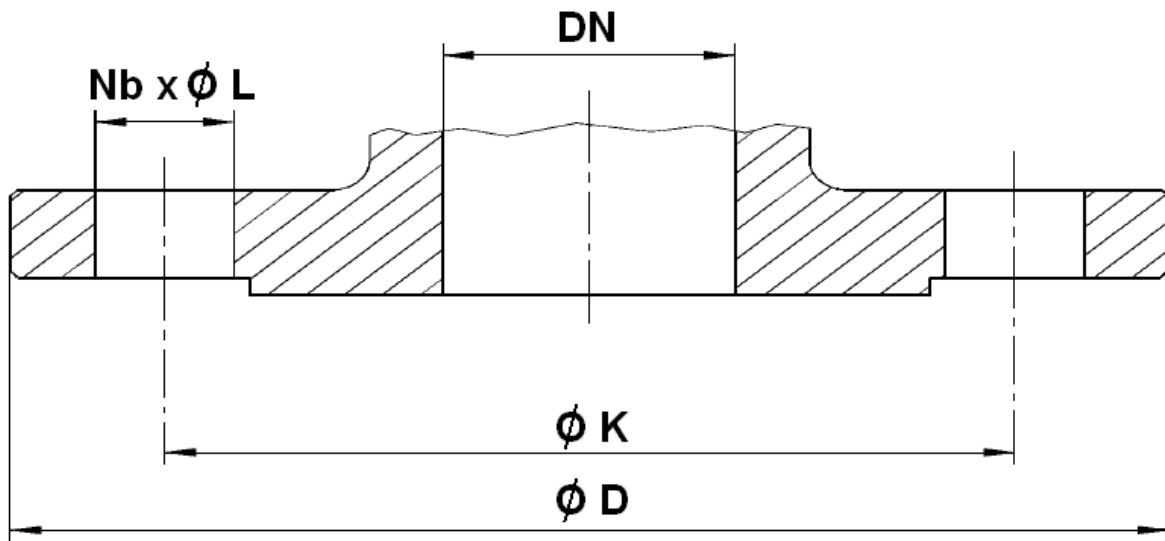

DN	50	65	80	100	125	150	200	250
Ø D	165	185	200	220	250	285	340	405
Ø K	125	145	160	180	210	240	295	355
Nb x Ø L	4 x 19	4 x 19	8 x 19	8 x 19	8 x 19	8 x 23	12 x 23	12 x 28

CAST IRON AXIAL DISC FOOT TYPE CHECK VALVE EPDM FLANGED PN16

STANDARDS :

- Manufacturer certified ISO 9001 : 2015
- DIRECTIVE 2014/68/EU : Products excluded from directive (Article 4, § 3)
- Certificate 3.1 on request
- Pressure tests according to API 598, table 6
- Flanged R.F. according to EN 1092-2 PN16

ADVICE : Our opinion and our advice are not guaranteed and SFERACO shall not be liable for the consequences of damages.
The customer must check the right choice of the products with the real service conditions.