

## STAINLESS STEEL 3 PIECES DISC CHECK VALVE SW

3 pieces disc check valve SW for drinking water, chemical and pharmaceutical industries, petrochemical industries, hydraulic installation, compressed air.

Stainless steel type with PTFE gaskets. All positions.

Removable central part for an easy maintenance.

Metal/metal tightness (leakage rate according to API 598 standard)



**Size :** DN8 to DN100

**Connection :** SW

**Min Temperature :** -20°C

**Max Temperature :** +200°C

**Max Pressure :** 63 Bars

**Specifications :** Disc type

All positions

Metal/metal tightness

In accordance with the regulation EC 1935-2004

**Materials :** Stainless steel EN 1.4408

STAINLESS STEEL 3 PIECES DISC CHECK VALVE SW

**SPECIFICATIONS :**

- 3 pieces spring type
- All positions (respect the flow direction indicated by the arrow )
- Metal / metal tightness
- Stainless steel

**USE :**

- Chemical and pharmaceutical industries, petrochemical industries, hydraulic installation, compressed air, potable water
- Min Temperature Ts : - 20°C
- Max Temperature Ts :+ 200°C
- Max Pressure Ps : 63 bars ( see graph under )
- Steam : 11 bars max

**PRESSURE / TEMPERATURE GRAPH ( STEAM EXCLUDED ) :**

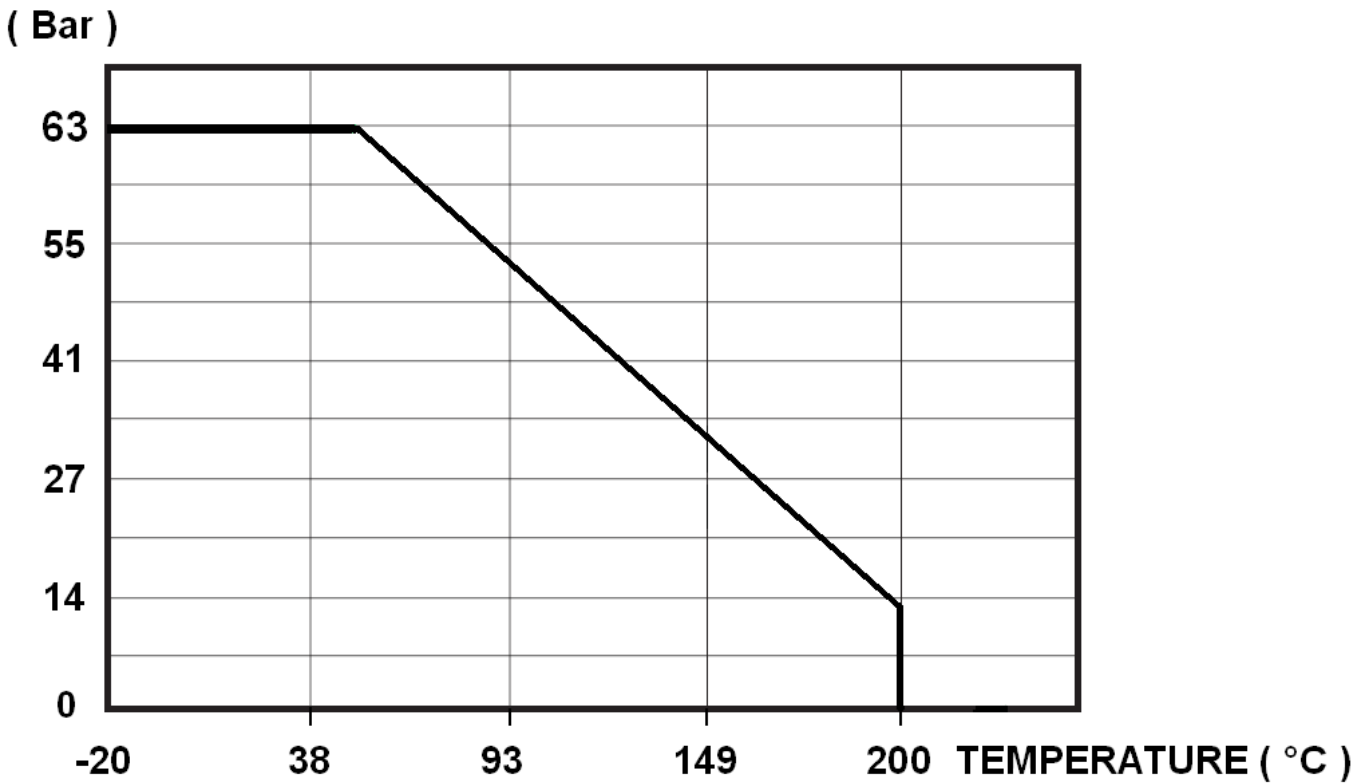

**FLOW COEFFICIENT Kvs ( M3 / h ) :**

DN (mm)	8	10	15	20	25	32	40	50	65	80	100
Kvs ( m3/h )	1.23	1.23	2.24	6.5	9.61	15.89	22.49	25.12	57.8	64.93	91.6

STAINLESS STEEL 3 PIECES DISC CHECK VALVE SW

HEAD LOSS GRAPH :

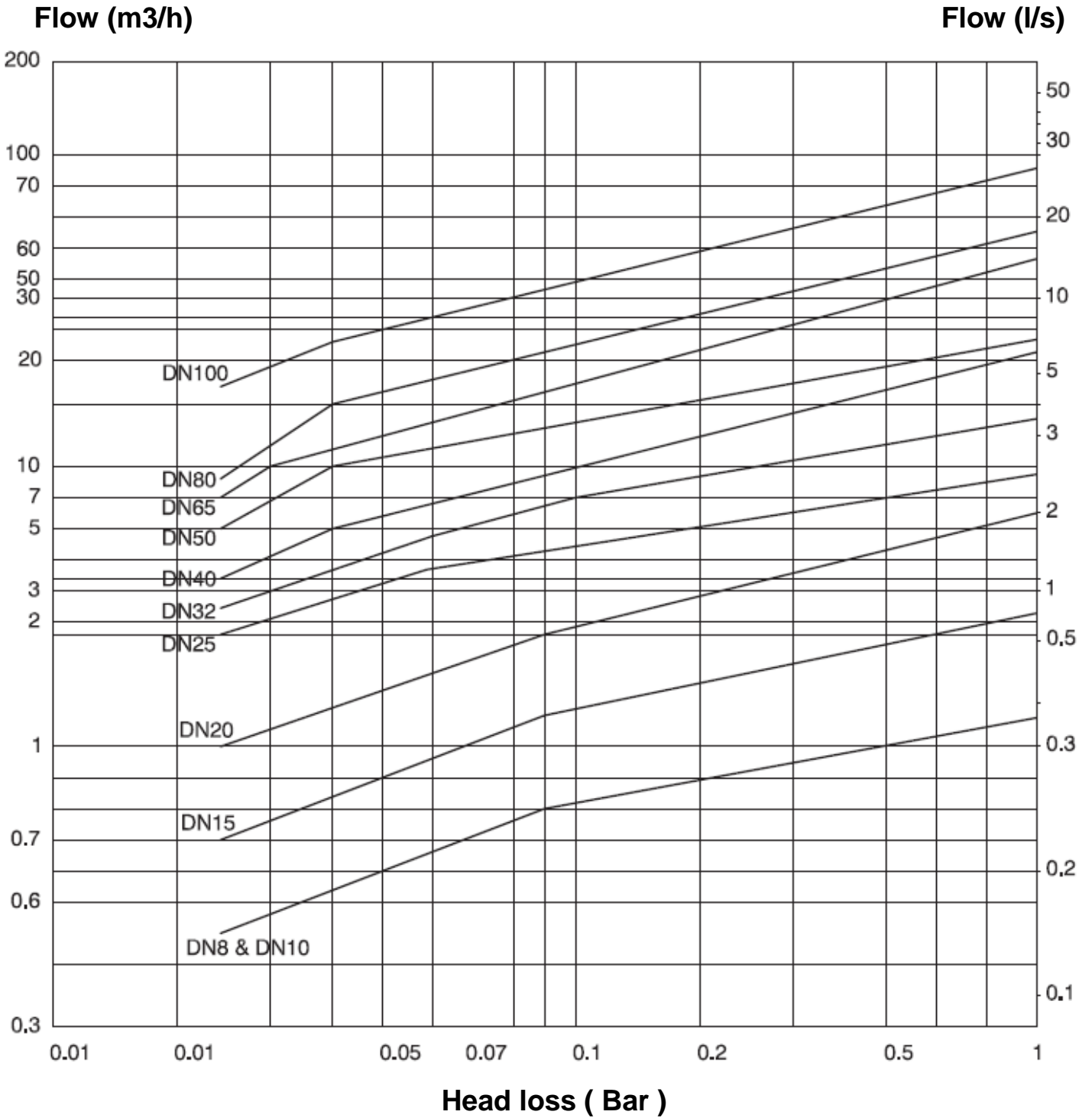

## STAINLESS STEEL 3 PIECES DISC CHECK VALVE SW

**LEAKAGE RATE ACCORDING TO API 598 (DURING 60s):**

NPS (")	1/4"	3/8"	1/2"	3/4"	1"	1"1/4"	1"1/2"	2"	2"1/2"	3"	4"
DN	8	10	15	20	25	32	40	50	65	80	100
Liquid Test ( cc/min )	6								7.5	9	12
Gas Test (m3/h)	0.08								0.11	0.13	0.17

**OPENING PRESSURE ( in mbar ) :**

DN	Vertical Position ascending fluid	Horizontal Position
DN 08	25 ↑	23 →
DN 10	25 ↑	23 →
DN 15	25 ↑	23 →
DN 20	25 ↑	23 →
DN 25	25 ↑	23 →
DN 32	27 ↑	24 →
DN 40	29 ↑	25 →
DN 50	29 ↑	25 →
DN 65	31 ↑	25 →
DN 80	32 ↑	26 →
DN100	33 ↑	27 →

**BOLT TIGHTENING TABLE ( in Nm):**

DN	8	10	15	20	25	32	40	50	65	80	100
Torque ( Nm )	30	30	30	30	45	45	45	60	75	90	105

**RANGE :**

- 3 pieces disc check valve SW Ref. 382 from DN8 to DN100

**STAINLESS STEEL 3 PIECES DISC CHECK VALVE SW**

**MATERIALS :**

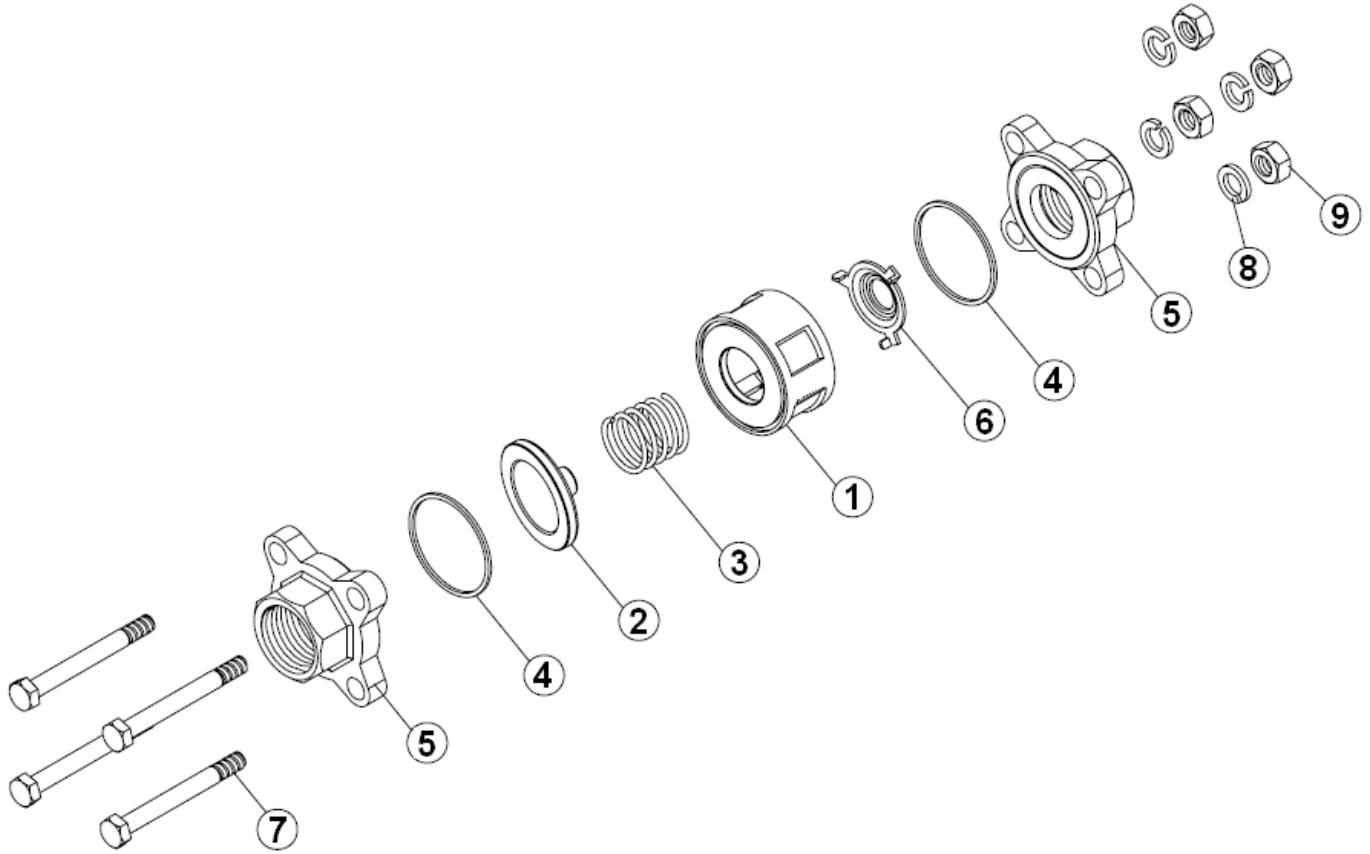

Item	Designation	Materials
1	Body	EN 1.4408
2	Disc	ASTM A240-316
3	Spring	
4	Gasket	PTFE
5	Ends	EN 1.4408
6	Spring holder	ASTM A240-316
7	Screw	AISI 304
8	Washer	
9	Nut	

**STAINLESS STEEL 3 PIECES DISC CHECK VALVE SW**

SIZE ( in mm ) :

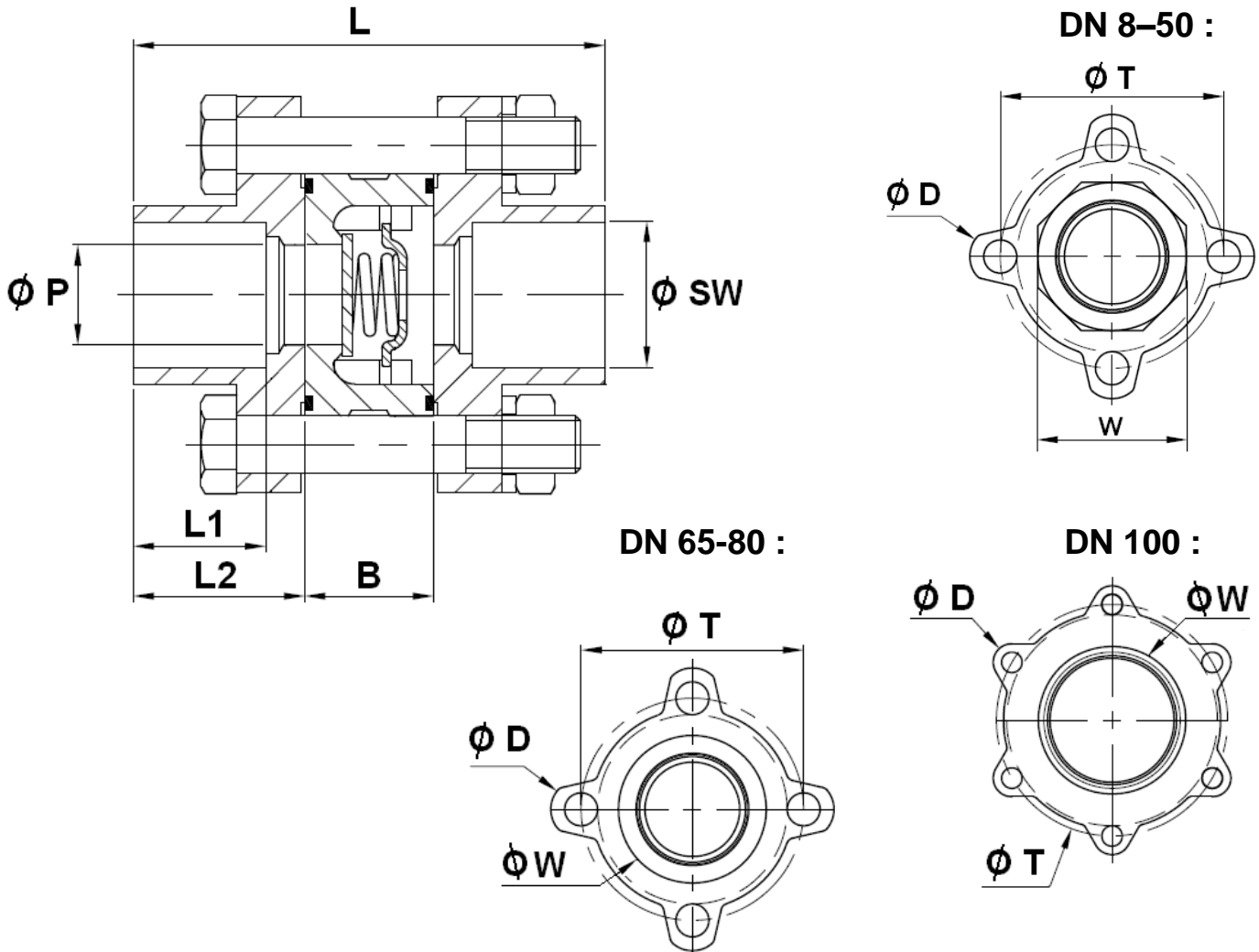

DN	8	10	15	20	25	32	40	50	65	80	100
Ø P	10	10	14	19	25	31	39	49	64	78	97
L	60	60	63	71	81.5	91	97.5	117	131.5	143.5	174.5
L1	15.5	16.5	12.5	14.1	15.7	17.7	19.5	22	26.3	28.7	37.5
L2	21	21	22	23.5	26	29	30	35	42	44	52
B	18	18	19	24	29.5	33	37.5	47	47.5	55.5	70.5
Ø D	12	12	14	16	16	18	18	18	18	18	18
W	22	22	26	32	39	49	56	69	83	100	122.5
Ø SW	14.2	17.5	21.8	27.4	34.1	42.7	49	61	77	90.2	115.3
Ø T	36.5	36.5	42.7	51.7	58.7	72.7	83.7	98.7	129	153.5	186.5
Weight (in Kg)	0.25	0.23	0.35	0.5	0.71	1.3	1.7	2.36	3.95	6.19	10.13
Ref.	382008	382010	382015	382020	382025	382032	382040	382050	382065	382080	382100

**STAINLESS STEEL 3 PIECES DISC CHECK VALVE SW****STANDARDS :**

- Manufacturer certified ISO 9001 : 2015
- DIRECTIVE 2014/68/EU : For liquids and gas of Group 1
  - DN8-25 : Article 4, §3 (SEP), no CE marking
  - DN32-100 : Risk Category II, CE 0035 marking
- Certificate 3.1 on request
- Construction according to EN 12516-1
- Designing according to ASME B16.34
- Pressure tests according to API 598, table 6
- SW ends according to DIN 3239-2 standard
- SW ends according to ASME B16.11 standard (excepted DN65)
- ATEX Group II Category 2 G/2D Zone 1 & 21 Zone 2 & 22 ( optional marking )
- French water agreement **A.C.S. N° 22 ACC LY 722 from DN8 to 50**
- Check valve in accordance with the regulation **(EC) N° 1935-2004 on request**

## STAINLESS STEEL 3 PIECES DISC CHECK VALVE SW

### INSTALLATION INSTRUCTIONS

#### GENERAL GUIDELINES :

- Ensure that the check valves to be used are appropriate for the conditions of the installation (type of fluid, pressure and temperature).
- Be sure to have enough valves to be able to isolate the sections of piping as well as the appropriate equipment for maintenance and repair.
- Ensure that the check valves to be installed are of correct strength to be able to support the capacity of their usage.
- **Installation of all circuits should ensure that their function can be automatically tested on a regular basis (at least two times a year).**

#### INSTALLATION INSTRUCTIONS :

- **Before installing the check valves, clean and remove any objects from the pipes** (in particular bits of sealing and metal) which could obstruct and block the check valves.
- **Ensure that both connecting pipes either side of the check valve (upstream and downstream) are aligned (if they're not, the valves may not work correctly).**
- **Make sure that the two sections of the pipe (upstream and downstream) match, the check valve unit will not absorb any gaps. Any distortions in the pipes may affect the tightness of the connection, the working of the check valve and can even cause a rupture.** To be sure, place the kit in position to ensure the assembling will work.
- **During welding operation, be sure to not exceed 200°C**
- **If sections of piping do not have their final support in place, they should be temporarily fixed. This is to avoid unnecessary strain on the check valve.**
- **Fluids in the check valve must not contain solid objects ( it could damaged the seat ).**
- If there is a direction changing or if there's another material, it's better to take away the check valve so that it is outside the turbulence area ( **between 3 and 5 times the ND before and after** ).
- After a pump please refer to **FD CEN/TR 13932** to install the check valve :
  - If it is essential to keep priming the pump, a non-return check valve can be fitted to the suction pipe at a distance **L1 ( straight length suction ) > 10xD1 (diameter suction )**  
The check valve is designed to meet the maximum flow rate in service
  - In other cases, the non-return check valve is mounted on the discharge pipe at a distance of **L2 (straight length at discharge) > 3xD2 (diameter at discharge)**