

CARBON STEEL WAFER SWING CHECK VALVE EPDM

PRODUCT EVOLUTION



Be careful, our check valves Ref.364 are changing

**We currently have 2 different types available (according to DN)
with different design and gaskets dimensions**

Marking for the new check valves N :

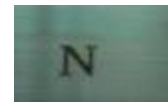

At the end, only the new types with marking N (new design) will be available (from page 2 to 6)

CARBON STEEL WAFER SWING CHECK VALVE EPDM

Wafer carbon steel swing check valve for heating and water distribution.

Carbon steel body and disc with EPDM seat.

Wafer type with short length and with a removable hoisting eye for easy installation.

NEW TYPE

Certificate

3.1



Size : DN 40 to 600

Connection : Between flanges PN10/16 up to DN150, PN16 over Class 150 (PN20) from DN100 to 400

Min Temperature : -10°C

Max Temperature : +110°C

Max Pressure : 16 Bars up to DN200, 10 bars over

Specifications : EPDM seat

Horizontal or vertical position with ascendant fluid

Wafer type

Removable hoisting eye

Weak headloss

Materials : Chromed Carbon Steel ASTM A216 WCB

CARBON STEEL WAFER SWING CHECK VALVE EPDM

SPECIFICATIONS :

- Wafer swing check valve
- Vertical position with ascendant fluid or horizontal position (respect the flow direction indicated by the arrow)
- Between flanges PN10/16 up to DN150, PN16 over and Class 150 (PN20) from DN100 to 400
- With removable hoisting eye
- Short length
- Economical solution
- Monobloc disc and stem for a better mechanical strength
- Integrated body gasket

USE :

- Heating, water distribution
- Min and max Temperature Ts : - 10°C to + 110°C
- Max Pressure Ps : 16 bars up to DN 200 included and 10 bars over
- **Do not use with pulsatory speed**
- **Max Speed : 3 M. / Sec.**

FLOW COEFFICIENT Kvs (in m3/h) :

DN	40	50	65	80	100	125	150	200
Kvs (m3/h)	21.88	44.72	46.72	117.89	226.23	453.44	649.86	1322.6
DN	250	300	350	400	450	500	600	
Kvs (m3/h)	2147.4	2993.2	4020.2	5430.7	6840	9080.8	13758.4	

CONNECTION :

- Carbon steel body with EPDM gasket between flanges PN10/16 up to DN150, PN16 over
- Between flanges Class 150 PN20 possible from DN100 to 400

CARBON STEEL WAFER SWING CHECK VALVE EPDM

MATERIALS :

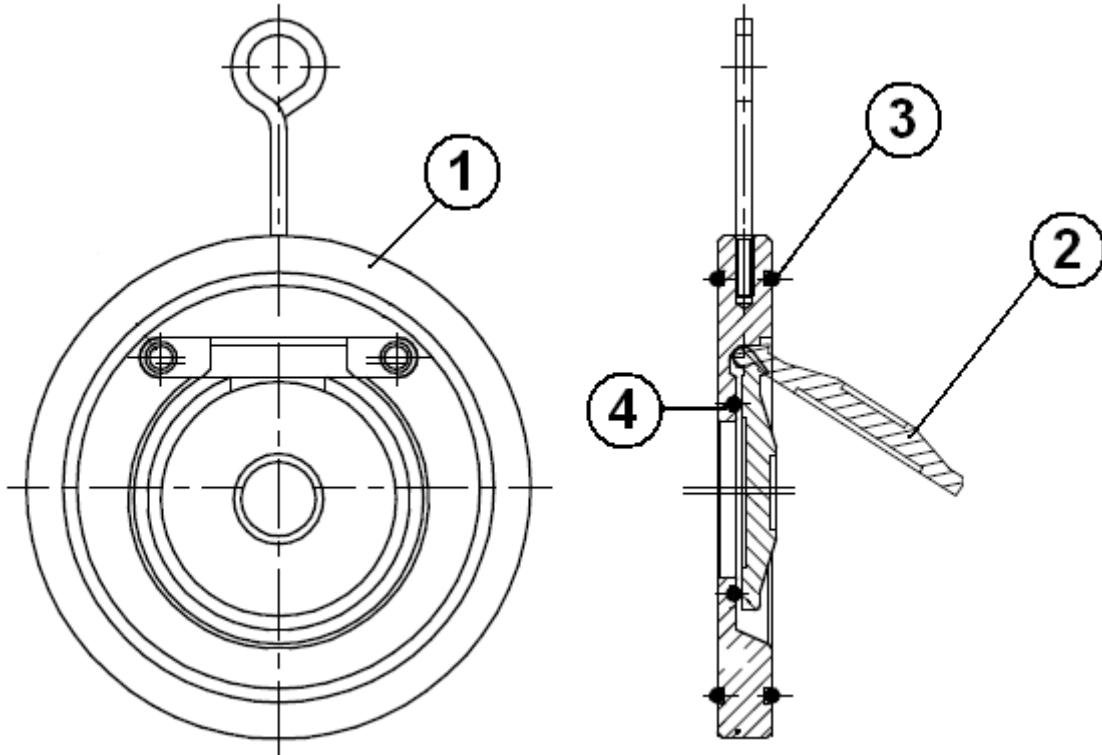

Item	Designation	Materials
1	Body	Chromed ASTM A216 WCB
2	Disc	
3	Seat	EPDM
4	Gasket	EPDM

CARBON STEEL WAFER SWING CHECK VALVE EPDM

SIZE (in mm):

CLOSED POSITION

GASKETS

OPENED POSITION

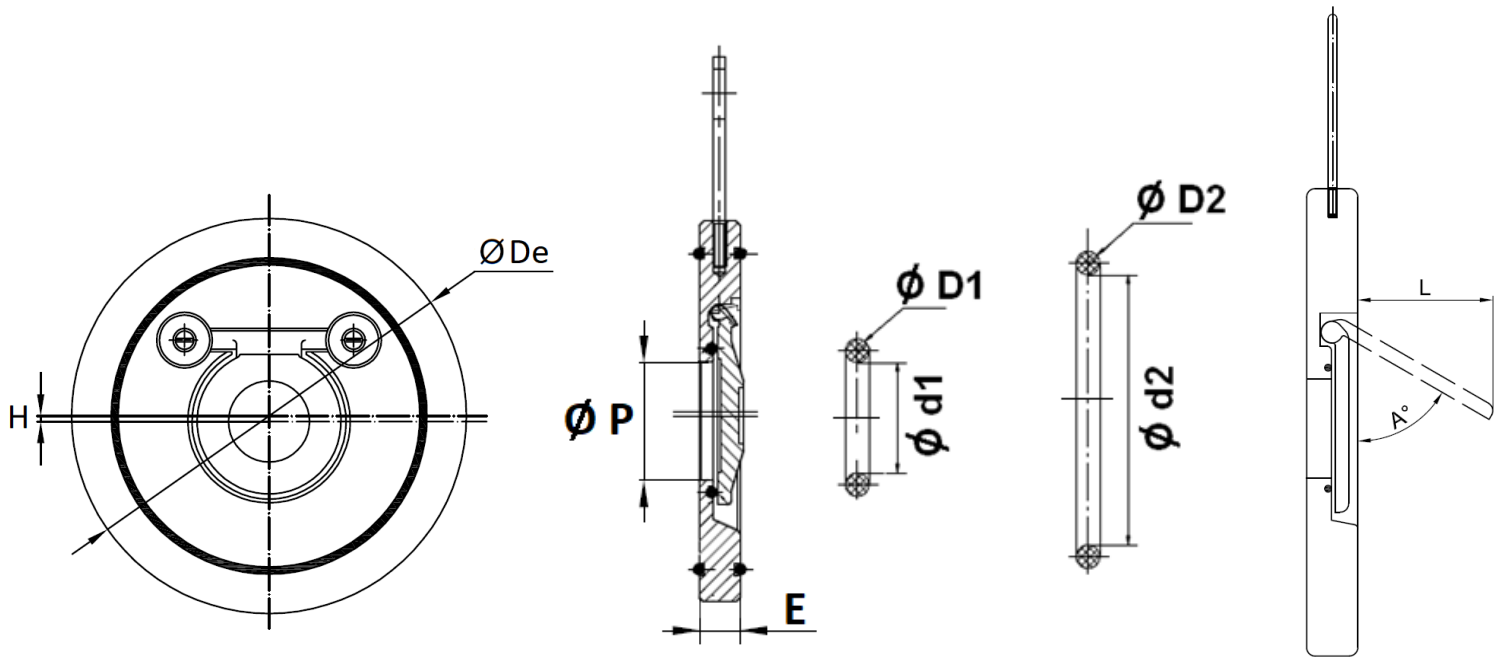

DN	40	50	65	80	100	125	150	200	250	300	350	400	450	500	600
E	14	14	14	14	18	18	20	22	26	32	38	44	50	56	62
Ø De	94	109	129	144	164	194	220	275	331	386	446	497	557	619	736
H	1		2	3			5			6	10	12			14
Ø P	19	27	28	43.5	60	83.5	100	141	179	212	246	285	320	366	448
L	25.3	33.7	42.1	54.2	72.1	92.9	111.9	150.3	190.5	228.1	253.4	291.5	328.6	366.2	446.8
A (°)		65	65	60.4	62.9	62.7	65.4	61.5	63.4	67.8	64.1	63.7	64.4	65.8	65.5
Ø d2	70.1	80.7	100.2	107.8	134.8	158	186	240.1	284.4	328	385	435	486	534	630
Ø D2	3.8									6	8				
Ø d1	21.6	29.3	34.8	48.7	62.9	84.8	101.5	144	181.6	216.4	259.2	298.2	336.2	382.2	468.2
Ø D1	3				3.8					6	8				
Weight (Kg)	0.69	0.86	1.2	1.49	2.42	3.29	4.72	7.92	13.73	21.04	31.5	47	70	96	135
Ref.	364040	364050	364065	364080	364100	364125	364150	364200	364250	364300	364350	364400	364450	364500	364600

CARBON STEEL WAFER SWING CHECK VALVE EPDM

STANDARDS :

- Manufacturer certified ISO 9001 : 2015
- Designing according to API 594 and EN 16767
- Pressure tests according to API 598, table 6
- DIRECTIVE 2014/68/EU: Products excluded (article 4, § 3)
- Certificate 3.1 on request
- Length according to EN 558 series 97 (NF 29377)
- Between flanges according to EN 1092-1 PN10/16

INSTALLATION POSITIONS :

Vertical position (ascendant fluid)

Horizontal position

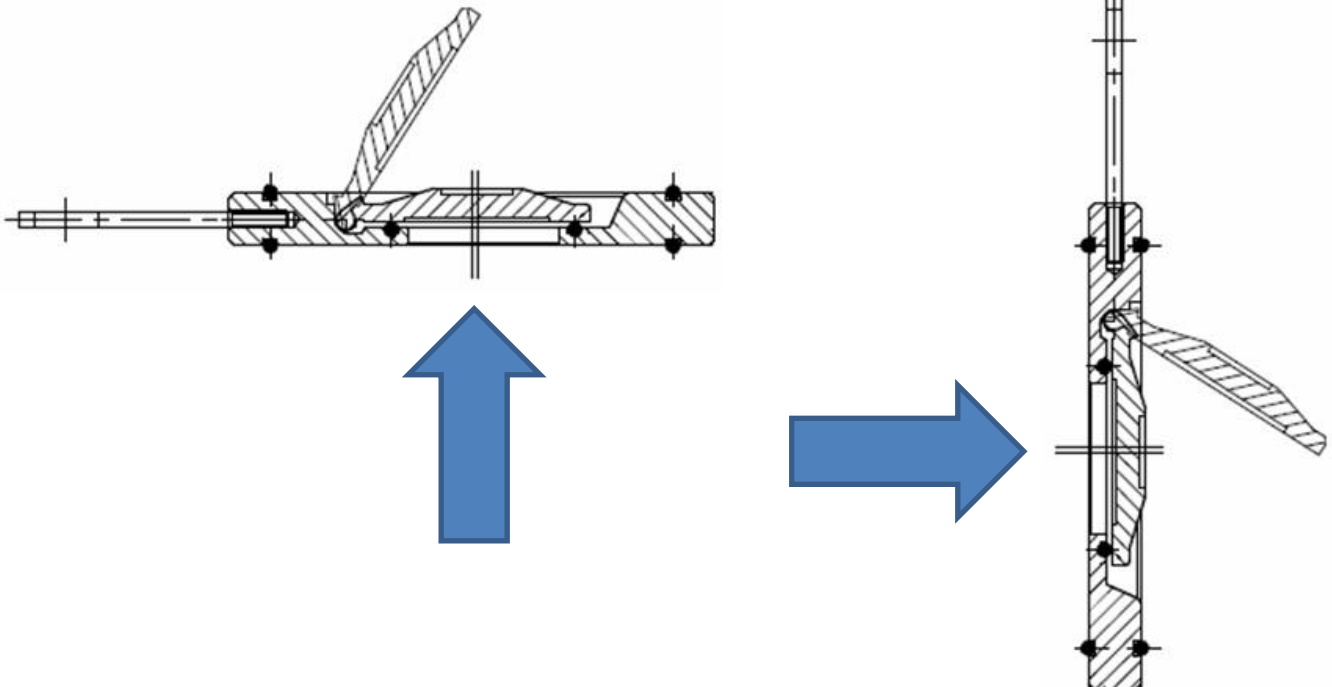

ADVICE : Our opinion and our advice are not guaranteed and SFERACO shall not be liable for the consequences of damages. The customer must check the right choice of the products with the real service conditions.

CARBON STEEL WAFER SWING CHECK VALVE EPDM

Wafer carbon steel swing check valve for heating and water distribution.

Carbon steel body and disc with EPDM seat.

Wafer type with short length and with a removable hoisting eye for easy installation.

Certificate

3.1



Size : DN 40 to 600

Connection : Between flanges PN10/16 up to DN150, PN16 over Class 150 (PN20) from DN100 to 400

Min Temperature : -10°C

Max Temperature : +110°C

Max Pressure : 16 Bars up to DN200, 10 bars over

Specifications : EPDM seat

Horizontal or vertical position with ascendant fluid

Wafer type

Removable hoisting eye

Weak headloss

Materials : Chromed Carbon Steel ASTM A216 WCB

CARBON STEEL WAFER SWING CHECK VALVE EPDM

SPECIFICATIONS :

- Wafer swing check valve
- Vertical position with ascendant fluid or horizontal position (respect the flow direction indicated by the arrow)
- Between flanges PN10/16 up to DN150, PN16 over and Class 150 (PN20) from DN100 to 400
- With removable hoisting eye
- Short length
- Economical solution
- Monobloc disc and stem for a better mechanical strength
- Integrated body gasket

USE :

- Heating, water distribution
- Min and max Temperature Ts : - 10°C to + 110°C
- Max Pressure Ps : 16 bars up to DN 200 included and 10 bars over
- **Do not use with pulsatory speed**
- **Max Speed : 3 M. / Sec.**

CONNECTION :

- Carbon steel body with EPDM gasket between flanges PN10/16 up to DN150, PN16 over
- Between flanges Class 150 PN20 possible from DN100 to 400

CARBON STEEL WAFER SWING CHECK VALVE EPDM

MATERIALS :

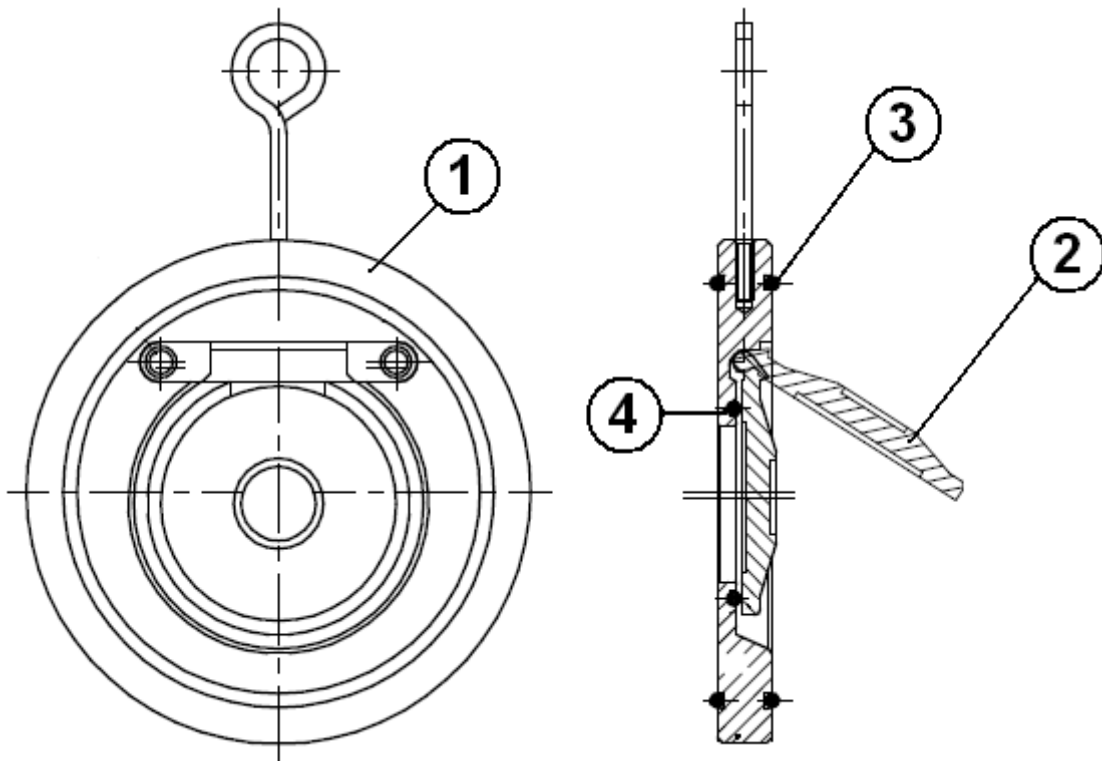

Item	Designation	Materials
1	Body	Chromed ASTM A216 WCB
2	Disc	
3	Seat	EPDM
4	Gasket	EPDM

CARBON STEEL WAFER SWING CHECK VALVE EPDM

SIZE (in mm) :

CLOSED CHECK VALVE

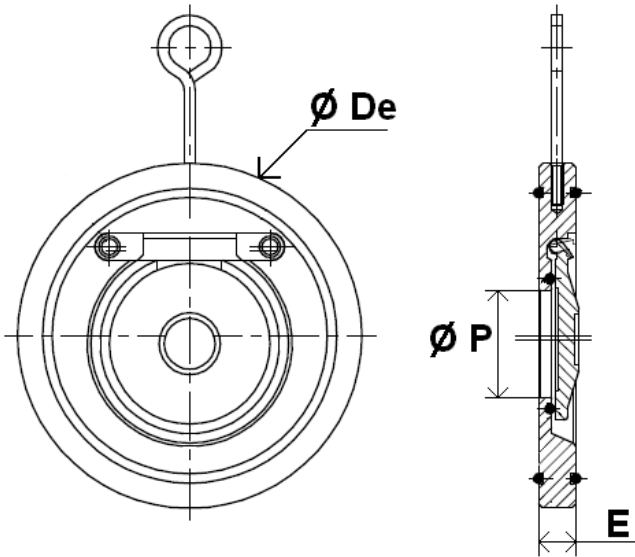

GASKETS

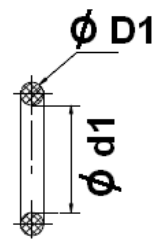

OPENED CHECK VALVE

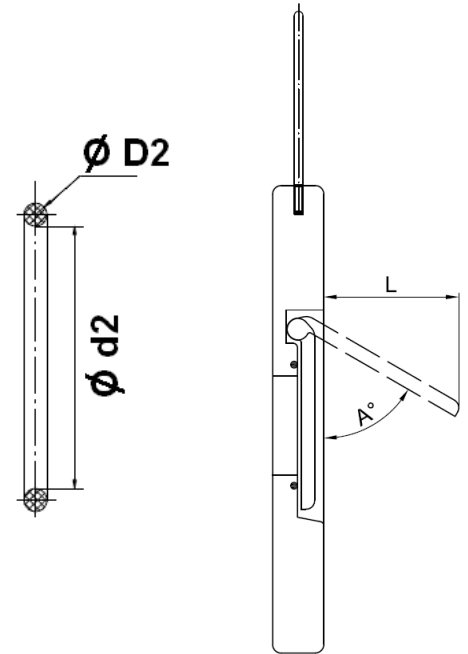

DN	40	50	65	80	100	125	150	200	250	300	350	400	450	500	600
E	14	14	14	14	18	18	20	22	26	32	38	44	50	56	62
Ø De	94	109	129	144	164	194	220	275	331	386	446	497	557	619	736
Ø P	22	32	40	54	70	92	112	154	192	227	270	315	358	410	490
L	26	38	51	62.5	77.5	96	118	159	194.5	241	272	326	374.5	417	495.5
A (°)	65														
Ø d2	70	80.5	100	107.5	134.5	158	186	240	284	328	385	435	486	534	630
Ø D2	3.8									6	8				
Ø d1	24	34	46.5	59	72.5	93	113.5	156.5	194.5	231	283	328	375	426	510
Ø D1	3				3.8					6	8				
Weight (Kg)	0.69	0.86	1.2	1.49	2.42	3.29	4.72	7.92	13.73	21.04	31.5	47	70	96	135
Ref.	364040	364050	364065	364080	364100	364125	364150	364200	364250	364300	364350	364400	364450	364500	364600

CARBON STEEL WAFER SWING CHECK VALVE EPDM

STANDARDS :

- Manufacturer certified ISO 9001 : 2015
- Designing according to API 594 and EN 16767
- Pressure tests according to API 598, table 6
- DIRECTIVE 2014/68/EU : Products excluded (article 4, § 3)
- Certificate 3.1 on request
- Length according to EN 558 series 97 (NF 29377)
- Between flanges according to EN 1092-1 PN10/16

INSTALLATION POSITIONS :

Vertical position (ascendant fluid)

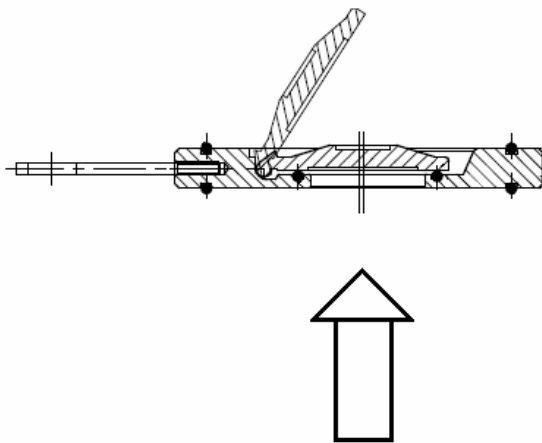

Horizontal position

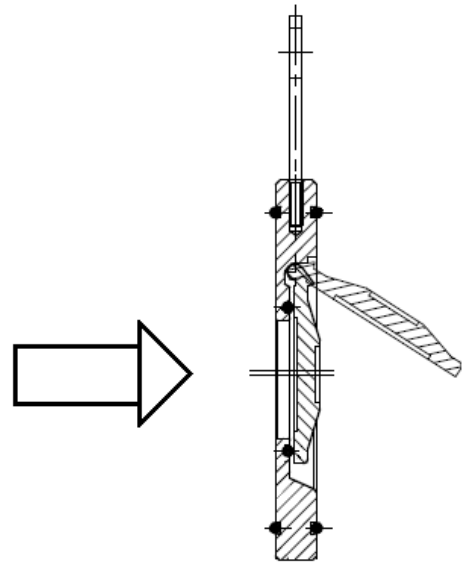

ADVICE : Our opinion and our advice are not guaranteed and SFERACO shall not be liable for the consequences of damages. The customer must check the right choice of the products with the real service conditions.