

CAST IRON AXIAL DISC CHECK VALVE EPDM WITH SPRING FLANGED PN16

Cast iron axial disc check valve for heating and water distribution.

Cast iron EN GJL-250 body coated with anti-corrosion epoxy painting, stainless steel disc and EPDM seat.

All positions thanks to the stainless steel spring.

Certificate

3.1



Size : DN50 to DN300

Connection : Between flanges PN16 RF

Min Temperature : -10°C

Max Temperature : +110°C

Max Pressure : 16 Bars

Specifications : Stainless steel disc

All positions

Stainless steel spring

Epoxy painting

Weak headloss

Materials : Cast iron EN GJL-250 body

CAST IRON AXIAL DISC CHECK VALVE EPDM WITH SPRING FLANGED PN16

SPECIFICATIONS :

- All positions
- Respect the flow direction indicated by the arrow
- Flanged R.F. PN16
- Stainless steel disc with spring
- Opening pressure about 0.3 bar
- Epoxy blue RAL 5005 painting 80 microns thickness
- Minimum backpressure for tightness: 1 bar

USE :

- Water distribution
- Min Temperature Ts : - 10°C
- Max Temperature Ts :+ 110°C
- Max Pressure Ps : 16 bars

RANGE :

- Flanged PN16 DN50 to DN300 Ref.369

HEAD LOSS GRAPH :

△ P

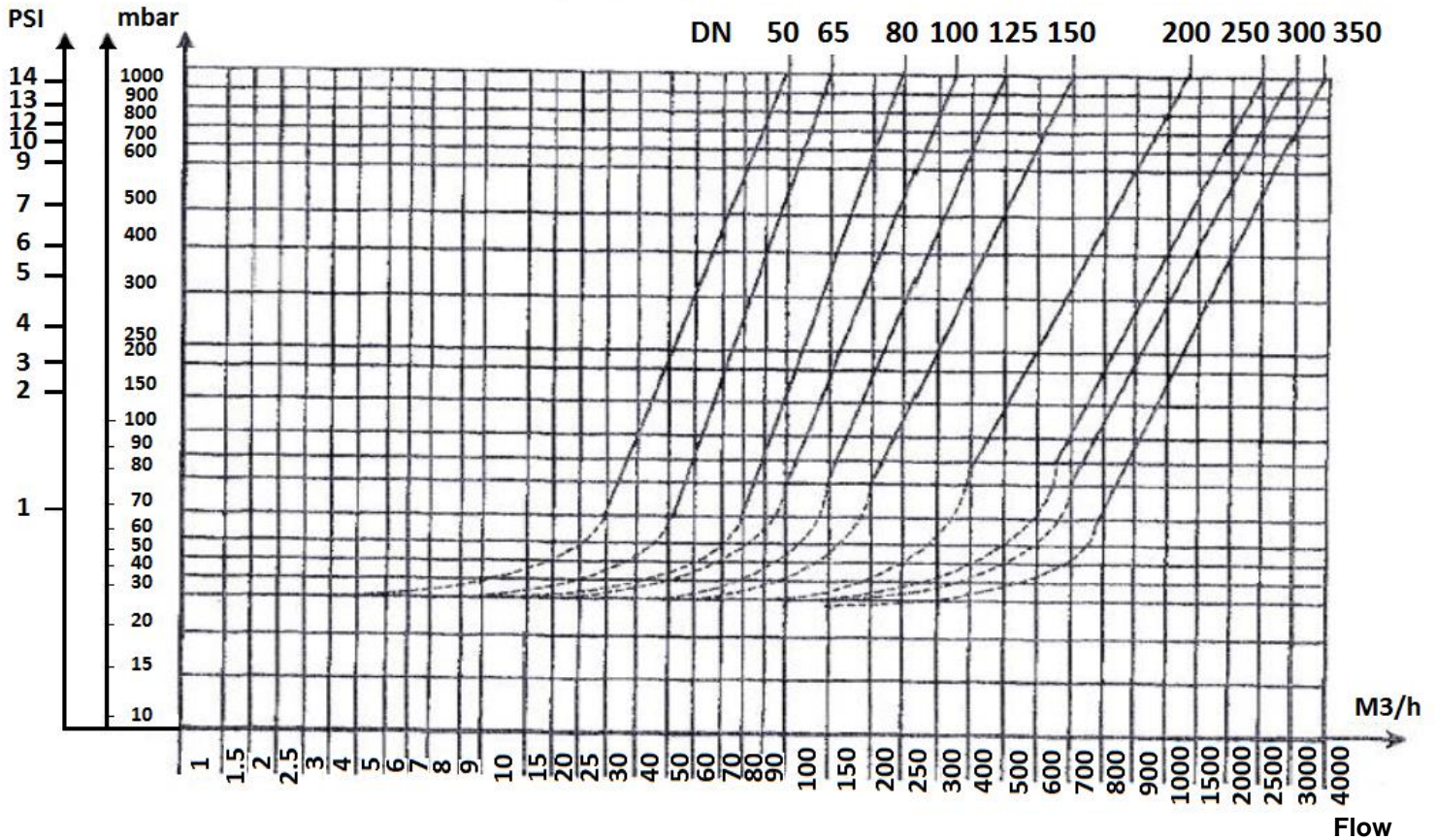

CAST IRON AXIAL DISC CHECK VALVE EPDM WITH SPRING FLANGED PN16

FLOW COEFFICIENT Kvs (in m3/h):

DN	50	65	80	100	125	150	200	250	300
Kvs (m3/h)	90	100	200	275	400	600	950	2000	2500

PRESSURE / TEMPERATURE GRAPH :

Pressure (Bar)

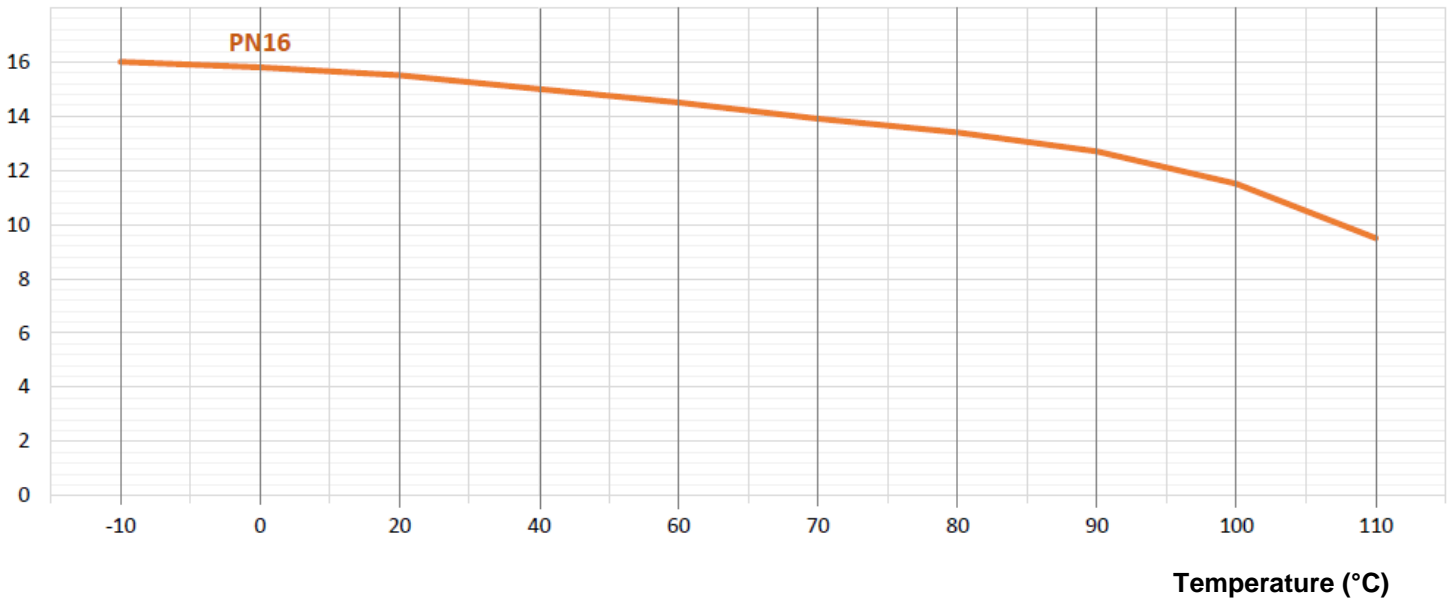

CAST IRON AXIAL DISC CHECK VALVE EPDM WITH SPRING FLANGED PN16

MATERIALS :

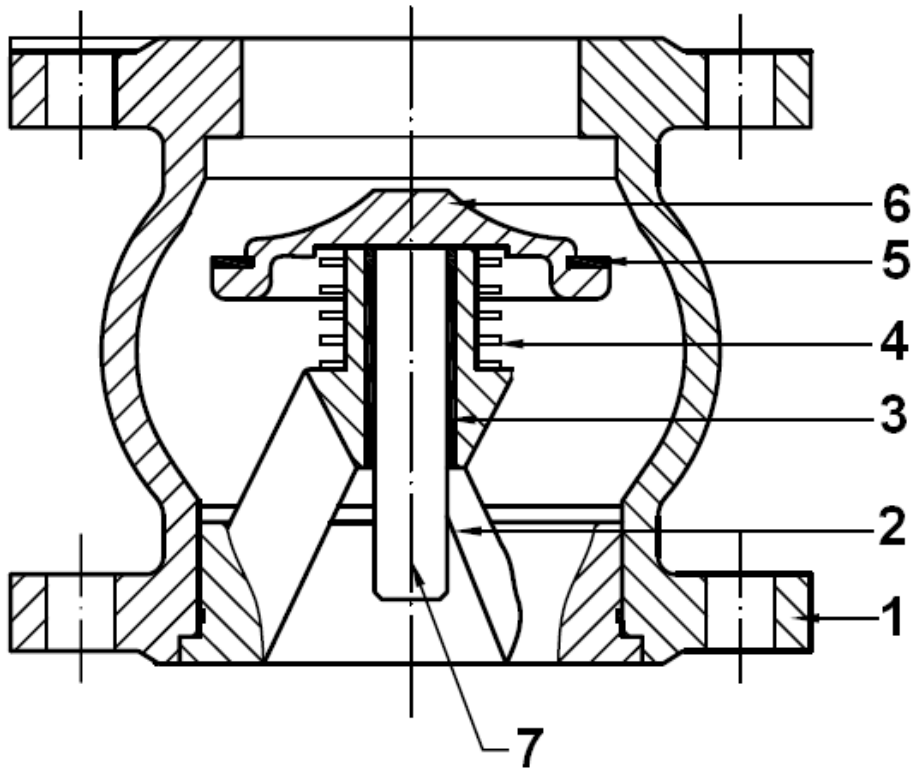

Item	Designation	Materials
1	Body	Cast iron EN-GJL-250
2	Guide	
3	Bushing	Bronze
4	Spring	AISI 304
5	Gasket	EPDM
6	Disc	AISI 304
7	Shaft	AISI 416

CAST IRON AXIAL DISC CHECK VALVE EPDM WITH SPRING FLANGED PN16

SIZE (in mm) :

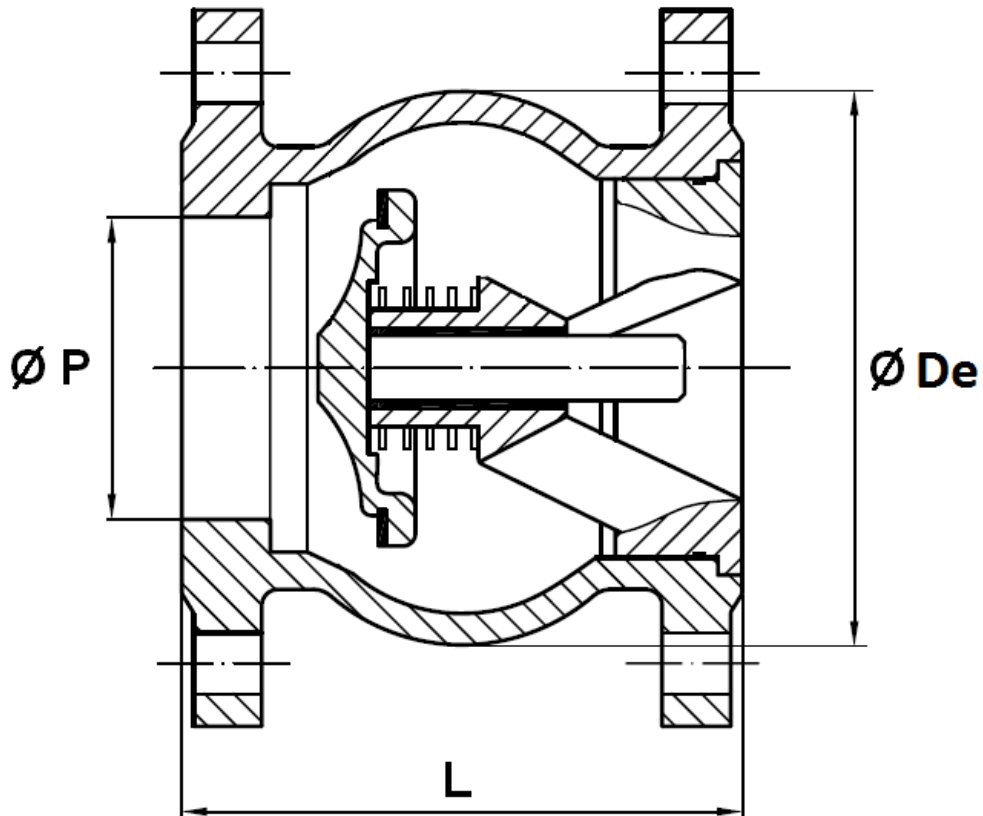

DN	50	65	80	100	125	150	200	250	300
Ø P	56	65	81	105	125	150	200	250	300
L	100	120	135	165	200	231	288	354	395
Ø De	104	135	160	194	233	269	338	429	493
Weight (in Kg)	6	9	11	15.5	23.5	34.5	56.5	97.5	145.5
Ref.	369050	369065	369080	369100	369125	369150	369200	369250	369300

CAST IRON AXIAL DISC CHECK VALVE EPDM WITH SPRING FLANGED PN16

FLANGES SIZE (in mm) :

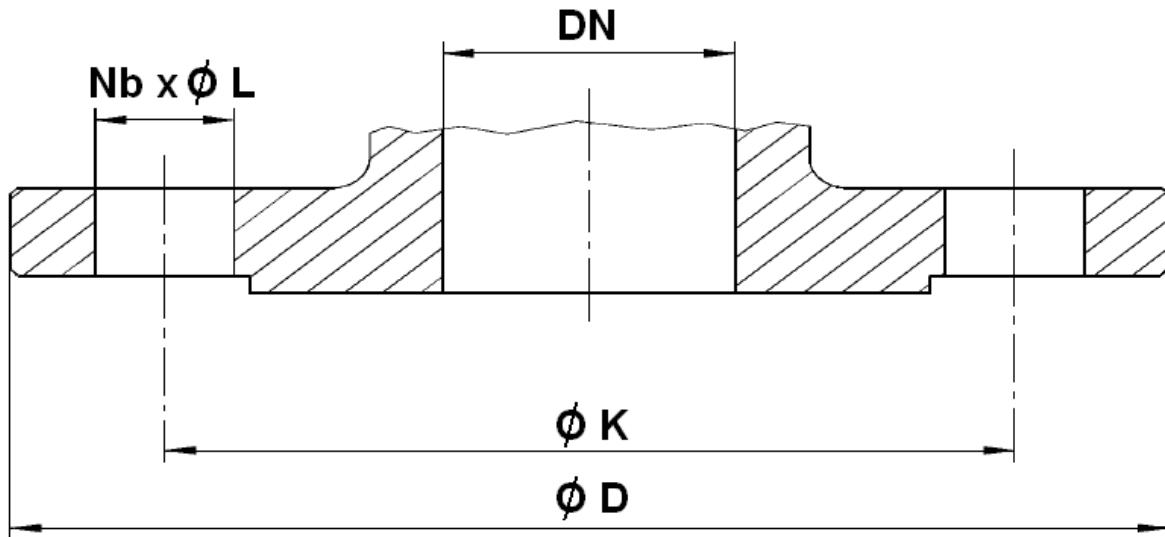

DN	50	65	80	100	125	150	200	250	300
Ø D	165	185	200	220	250	285	340	405	460
Ø K	125	145	160	180	210	240	295	355	410
Nb x Ø L	4 x 19	4 x 19	8 x 19	8 x 19	8 x 19	8 x 23	12 x 23	12 x 28	12 x 28

STANDARDS :

- Manufacturer certified ISO 9001 : 2015
- DIRECTIVE 2014/68/EU : Products excluded from directive (Article 4, § 3)
- Certificate 3.1 on request
- Pressure tests according to API 598, table 6
- Flanged R.F. according to EN 1092-2 PN16

ADVICE : Our opinion and our advice are not guaranteed and SFERACO shall not be liable for the consequences of damages. The customer must check the right choice of the products with the real service conditions.