

# 505-507 VALVES WITH TCR ELECTRICAL ACTUATOR

## FEATURES

The 505+TCR and 507+TCR cast iron ball valves are dedicated to the automatic opening/shut-off of pipes carrying low pressure unloaded common fluids. The 505-507 full bore split body ball valve has the EC 2014/68 certification. The 505 valve complies with the NF 29323 face-to-face standards and the 507 valve complies with the DIN 3202 F4/F5 face-to-face standards. The ISO 5211 pad allows a direct mounting of the TCR actuator. It is perfectly suitable for S3- S4 type service factors with indoor or outdoor installation under shelter.

## AVAILABLE MODELS

**505** : Face to face according to NF 29-323 F18 standard for DN 40 to 150.

**507** : Face to face according to EN 558-1 series 27 DN 15 to 150.

Flanged connections RF PN10/16.

**Supply voltages** : 24 Vdc, 24 Vac and 230 Vac.

## LIMITS OF USE

Fluid pressure : PS	16 bar (20°C)
Fluid temperature : WT°	-10°C / +200°C
Prohibited use	Steam, compressed air and gases
Ambiant temperature	- 10°C / + 50°C
Service factor	S4 - 50% (TCR 02N-05N-11N)
	S3 - 85% (TCR 20N-40N)

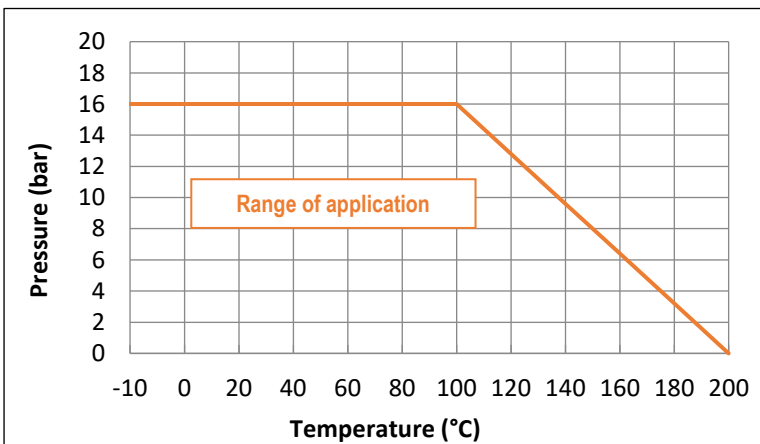
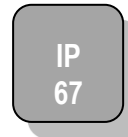

## DIRECTIVES AND MANUFACTURING STANDARDS

OBJET	Standard	OBJET	Standard
Pressure Equipment Directive 2014/68/EC	<b>DN 15 and 20</b> : not subject	Final test	EN 12266-1
	<b>DN 25 to 200</b> : category I	Face-to-face dimension 505	NF 29-323
Conception	DIN 3357	Face-to-face dimension 507	EN 558-1 series 27
Size	DIN 3840	Marking code	EN 19
Flanged dimension	EN 1092-2	Motorisation connection	ISO 5211

Information given as an indication only, and subject to possible modifications



# 505-507 VALVES WITH TCR ELECTRICAL ACTUATOR

## CONSTRUCTION

No.	Name	Material	No.	Name	Material
1	Body	EN GJL-250 Cast Iron	8	O-ring	FKM
2	End	EN GJL-250 Cast Iron	9	Washer	DIN 471 steel
3	Ball DN 40-150 (505)	SS 304 Stainless steel	10	Nut	DIN 934-8 steel
3	Ball DN 15-25 (507)	SS 303 Stainless steel	11	Screw	DIN 912- 8.8 steel
3	Ball DN 32-200 (507)	SS 304 Stainless steel	12	Washer	Zinc plated steel
4	Stem	SS 304 Stainless steel	13	Screw	DIN 935 5.6
5	Seat	PTFE	14	Handle	Steel
6	Friction ring	PTFE	15	Screw	DIN 933 5.6
7	Body gasket	PTFE			

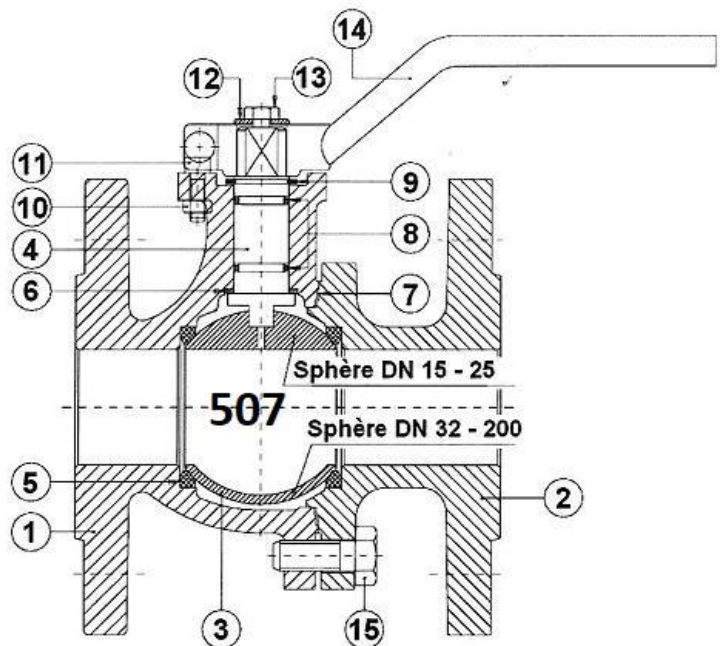
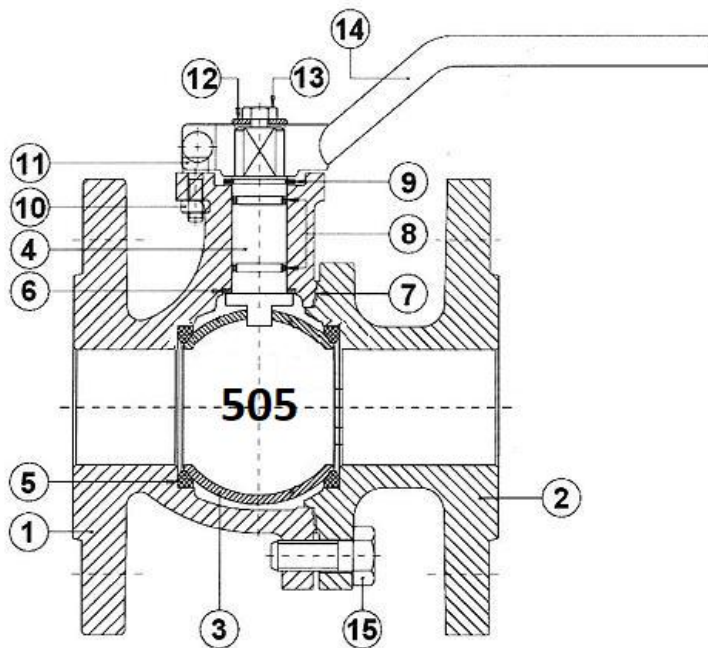

Information given as an indication only, and subject to possible modifications

# 505-507 VALVES WITH TCR ELECTRICAL ACTUATOR

## DIMENSIONS (mm)

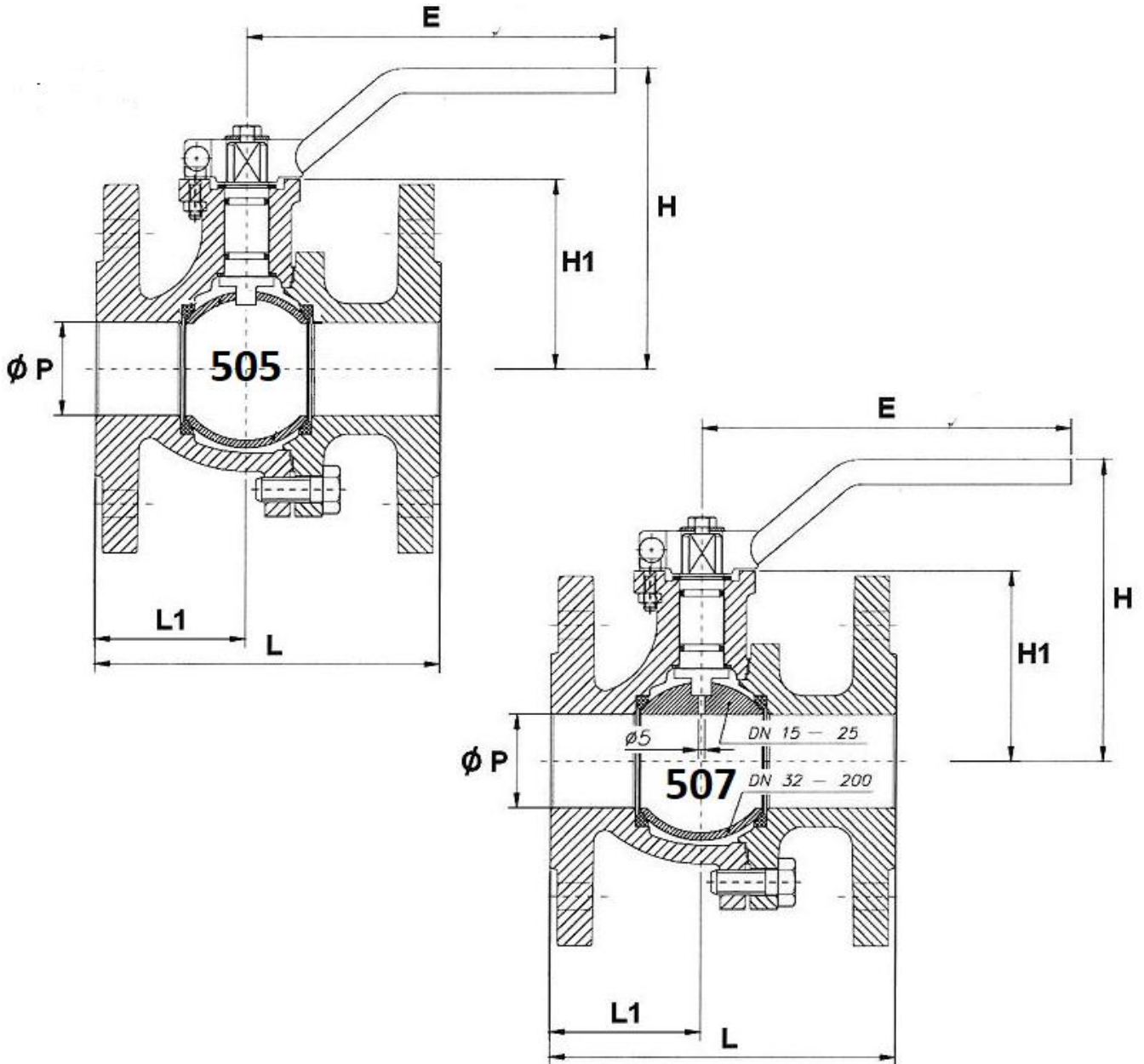

DN	15	20	25	32	40	50	65	80	100	125	150	200
Ø P	13	17	24	31	38	50	65	80	100	125	150	200
L (505)	/	/	/	/	136	142	154	160	172	186	200	/
L (507)	115	120	125	130	140	150	170	180	190	200	210	400
L1	49	55.5	51.5	53	61	62	81.5	79	94	120.5	155	190
H	92	95.5	102.2	114.7	119	127	141	151.5	176.5	208	254.2	293.5
H1	48.5	53	59.5	72	77	85	98	108.5	134	165	190	229
E	170	170	170	170	302.5	302.5	224	335	350	350	500	500
Weight (kg)	2.12	2.72	3.62	5.32	6.90	9.00	11.7	14.7	20.2	33.8	49.8	81.8

Information given as an indication only, and subject to possible modifications



# 505-507 VALVES WITH TCR ELECTRICAL ACTUATOR

## FLOW-RATE COEFFICIENT Kv (m<sup>3</sup>/h)

DN	15	20	25	32	40	50	65	80	100	125	150	200
Kv (505)	/	/	/	/	223	416	660	1200	1980	3600	5040	/
Kv (507)	37.4	74.8	105	176	223	416	660	1200	1980	3600	5040	10890

## TCR ELECTRICAL MOTORISATION

The TCR motorisation proposed as standard comprises:

- IP67 plastic housing for actuator and steel gear box,
- a safety coefficient of 1.3 minimum compared to the nominal torque of the valve,
- an upstream / downstream pressure difference  $\Delta P=10$  bar max.

The actuator's assembly with yoke and trainer.

DN	Actuator	Power 230V ac / 24V ac-dc	Time 230V ac	Time 24 V ac-dc	Standard equipment of the electric actuator
15 (507)	TCR-02N	15	10s	10s	2 adjustable limit switches 2 dry auxiliary contacts Thermal protection of the motor 2-3W anti-condensation resistance Stand-by manual control with key 3D Position visual indicator Electrical connection: <b>TRC02</b> : 1 x PE M10 + 1,5m cable <b>TCR05</b> : 1 x PE M20 + 1,5m cable <b>TCR11</b> : 2 x PE M14 + 1,5m cable <b>TCR20</b> : 2 x PE M20 + 1,5m cable <b>TCR40</b> : 2 x PE M20 + 1,5m cable
20 (507)	TCR-02N	15	10s	10s	
25 (507)	TCR-02N	15	10s	10s	
32 (507)	TCR-05N	25	12s	12s	
40	TCR-05N	25	12s	12s	
50	TCR-11N	100	10s	10s	
65*	TCR-11N	100	10s	10s	
80	TCR-11N	100	10s	10s	
100	TCR-20N	50	25s	25s	
125	TCR-40N	80	25s	25s	
150	TCR-40N	80	25s	25s	

For any other operating conditions, please contact us.

\* indicative time for actuator running empty

## MOTORISATION OPTIONS

There are many options for which you are invited to contact our sales service :

1	Actuator dimensioned for an upstream / downstream pressure difference $\Delta P$ greater than 10 bar
2	NF actuator – return via condenser – TCR-KT32
3	High-speed actuator - TRC-NH
4	Smart actuator with manoeuvring time adjustment - TCR-C
5	Control actuator – TCR-T
6	NF control actuator – return via condenser – TCR-T-KT32
7	Field bus actuator - TCR-B
8	Actuator with in-built timer – TCR-D
9	Wireless actuator – TCR-R

Information given as an indication only, and subject to possible modifications



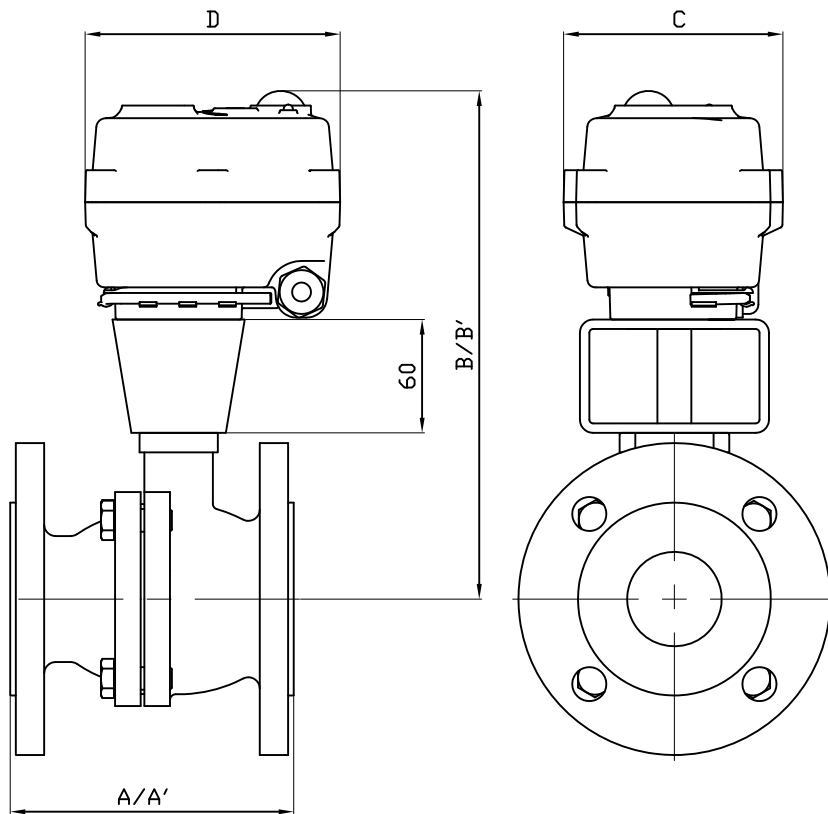

TCR-02-05

DN	15	20	25	32	40
SERVO	TCR 02	TCR 02	TCR 02	TCR 05	TCR 05
A<505>	-	-	-	-	136
A'<507>	115	120	125	130	140
B<505>	-	-	-	-	258
B'<507>	198.5	203	209.5	253	258
C	70	70	70	111	111
D	104	104	104	132	132
KG<505>	-	-	-	-	7.8
KG'<507>	4.7	5.1	5.3	7.3	8.82

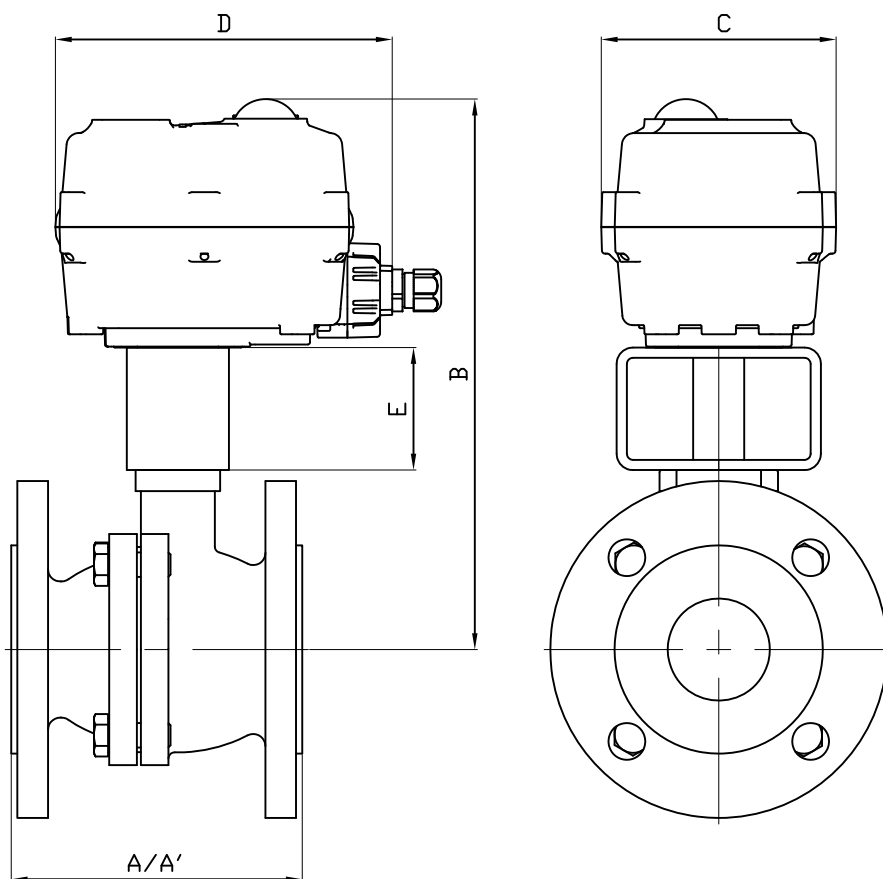

TCR 11-20-40

DN	50	65	80	100	125	150
SERVO	TCR11	TCR11	TCR11	TCR20	TCR40	TCR40
A<505>	142	154	160	172	186	200
A<507>	150	170	180	190	200	210
B	267	280	290.5	386	417	442
C	115	115	115	160	160	160
D	165	165	165	270	270	270
E	60	60	60	80	80	80
KG<505>	11.7	15.9	18.9	26.4	35.4	52.6
KG<507>	12.2	15.9	19.1	27.3	40.4	55.1

# TCR-N ELECTRICAL ACTUATOR

## FEATURES

The TCR-N electric actuators are intended for motorising ¼ turn valves with a torque of 15, 20, 50, 110, 200 or 400 Nm. With a compact construction and plastic housing, they are especially well suited for motorising ball valves and butterfly valves. Several variants offer advanced functions. IP67 leak-tightness: to be used indoors and, possibly, outdoors under a shelter. Possible installation in parallel. Manual control with a key.

## AVAILABLE MODELS

Supply voltages: 230V AC, 24V AC/DC, 12V DC.



## LIMITS OF USE

IP Code	IP 67
Ambient temperature	- 20°C / +60°C
Service factor	S4 - 50% (TCR 02-05-11)
	S3 - 85% (TCR 20-40)

## MECHANICAL FEATURES

Gear box	treated steel pinions
Torques	15 - 20 - 50 - 110 - 200 - 400 Nm
Angle of rotation	90° +/- 2°
Declutching	Without (TCR 02-05-11)
	With (TCR 20-40)
Override control	By key



Actuator	TCR 02N			TCR 05N		
	Torques (Nm)	15	20	20	50	
Voltage	12V DC	24V AC-DC	95-265V AC-DC	12VDC	24V AC-DC	95-265V AC-DC
Manoeuvring time (s)	15	10	10	12	12	12
ISO 5211:	F03/F05 - star 11			F05/F07 - star 14		

Actuator	TCR 11N			TCR 20N			TCR 40N		
	Torques (Nm)	110			200			400	
Voltage	12V DC	24V AC-DC	95-265V AC-DC	12VDC	24V AC-DC	95-265V AC-DC	12V DC	24V AC-DC	95-265V AC-DC
Manoeuvring time (s)	10	10	10	25	25	25	25	25	25
ISO 5211:	F05/F07 - star 17			F07/F10 - star 22			F07/F10 - star 22		

Information given as an indication only, and subject to possible modifications



# TCR-N ELECTRICAL ACTUATOR

## ELECTRICAL FEATURES

Actuator	TCR 02N	TCR 05N
Motor protection	Thermal switch	
Limit switches	2 adjustable switches	
Auxiliary switches	2 adjustable dry switches	
Anti-condensation	integrated	
Electrical connection	PE M10 + 1.5m cable	PE M20 + 1.5m cable

Actuator	TCR 02N			TCR 05N		
Voltage	12V DC	24V AC-DC	95-265V AC-DC	12V DC	24V AC-DC	95-265V AC-DC
Power (W)	15	15	15	25	25	25
Current (A)	1,5	1,5	0,09	1,67		0,18 - 0,37
Fuse Protection (A)	5	5	1	8		1 - 2

Actuator	TCR 11N	TCR 20N	TCR 40N
Motor protection	Thermal switch		
Limit switches	2 adjustable switches		
Auxiliary switches	2 adjustable dry switches		
Anti-condensation	Integrated		
Electrical connection	2 x PE M14 + 1,5m cable	2 x PE M20 + 1.5m cable	2 x PE M20 + 1,5m cable

Actuator	TCR 11N			TCR 20N			TCR 40N		
Voltage	12V DC	24V AC-DC	95-265V AC-DC	12V DC	24V AC-DC	95-265V AC-DC	12V DC	24V AC-DC	95-265V AC-DC
Power (W)	100	100	100	50	50	50	80	80	80
Current (A)	2,5		0,3 - 0,6	2		0,22	3,3		0,36
Fuse Protection (A)	5		2 - 3	3		5	8		2

Information given as an indication only, and subject to possible modifications





# TCR-N ELECTRICAL ACTUATOR

## CONSTRUCTION (TCR-02N)

TCR-02N					
No.	Name	Material	No.	Name	Material
1	Casing + lid	Plastic (ABS)	6	Rating plate	PVC
2	Position indicator	Polycarbonate plastic	7	Key support	Plastic (ABS)
3	Screw x 4	Aisi 304	8	Hex key	Steel
4	Backup control stem	Aisi 304	9	Packing gland	Nylon
5	Gasket	NBR	10	Cover gasket	NBR

Weight (kg): 0.620

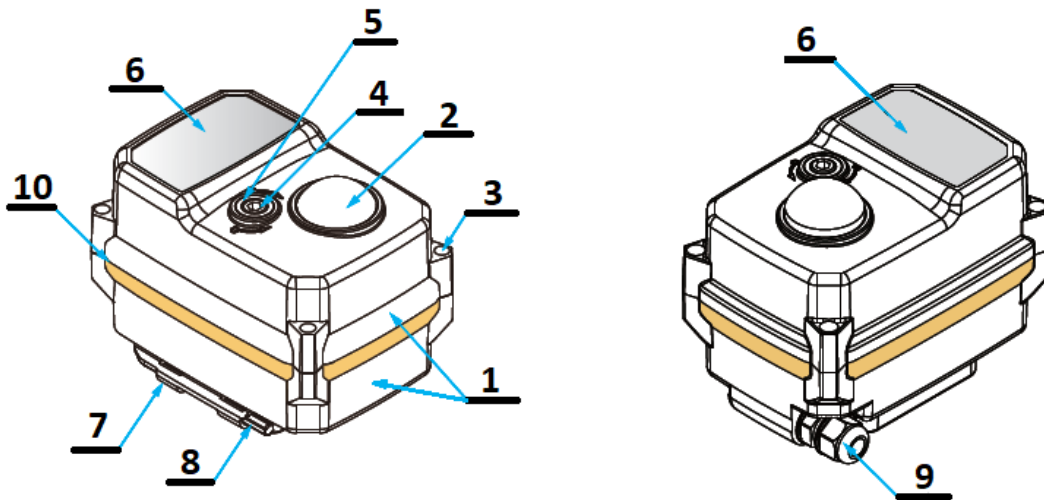

## DIMENSIONS (mm)

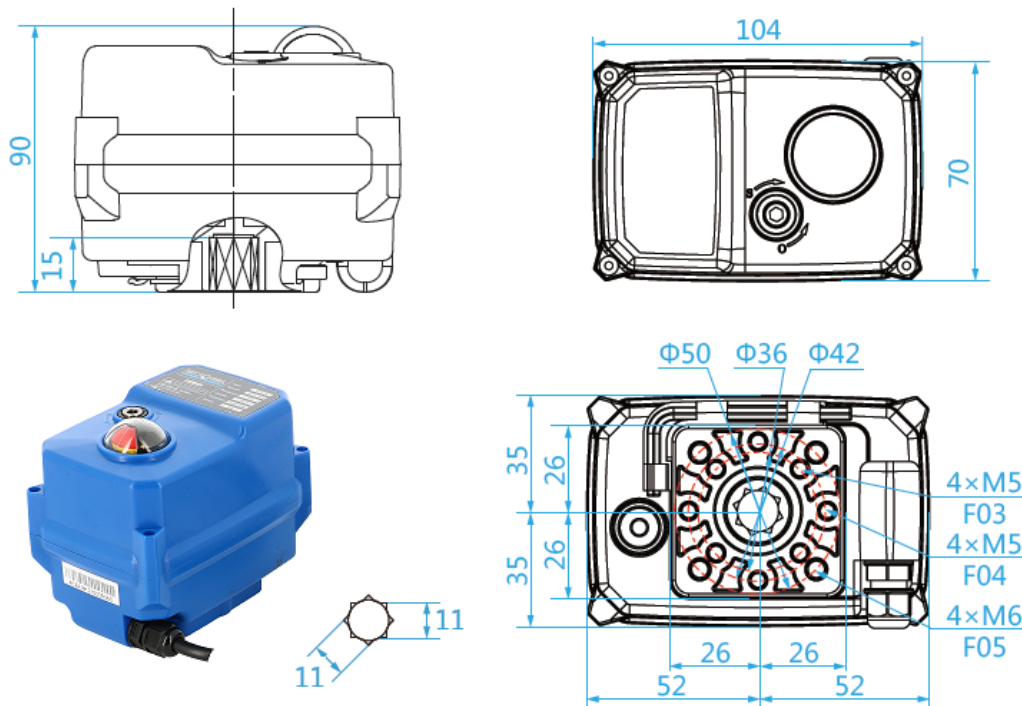

Information given as an indication only, and subject to possible modifications

# TCR-N ELECTRICAL ACTUATOR

## CONSTRUCTION (TCR-05N)

TCR-05N					
No.	Name	Material	No.	Name	Material
1	Casing + lid	Plastic (ABS)	6	Rating plate	PVC
2	Position indicator	Polycarbonate plastic	7	Key support	Plastic (ABS)
3	Screw x 6	Aisi 304	8	Hex key	Steel
4	Backup control stem	Aisi 304	9	Packing gland	Nylon
5	Gasket	NBR	10	Cover gasket	NBR

Weight (kg): 1.800

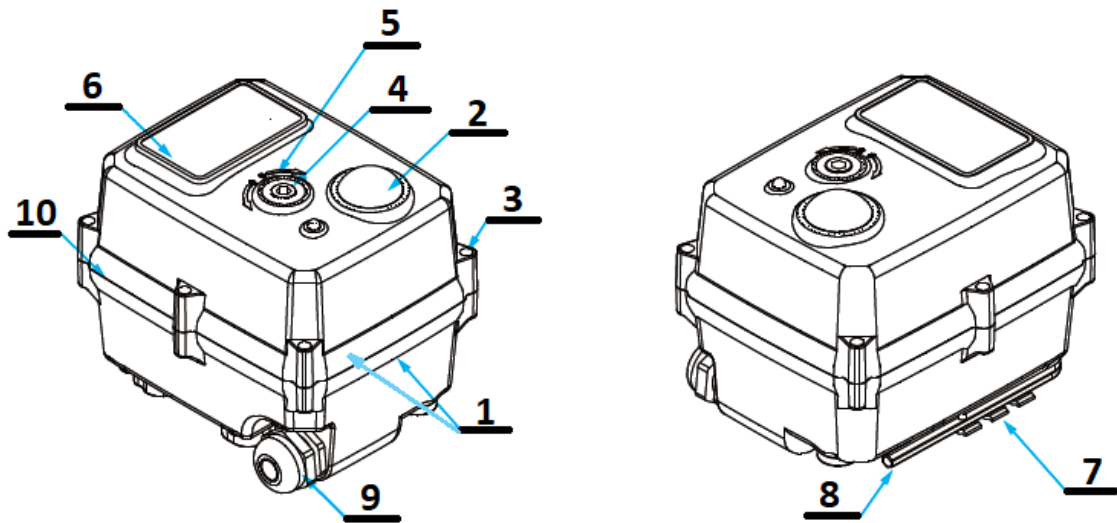

## DIMENSIONS (mm)

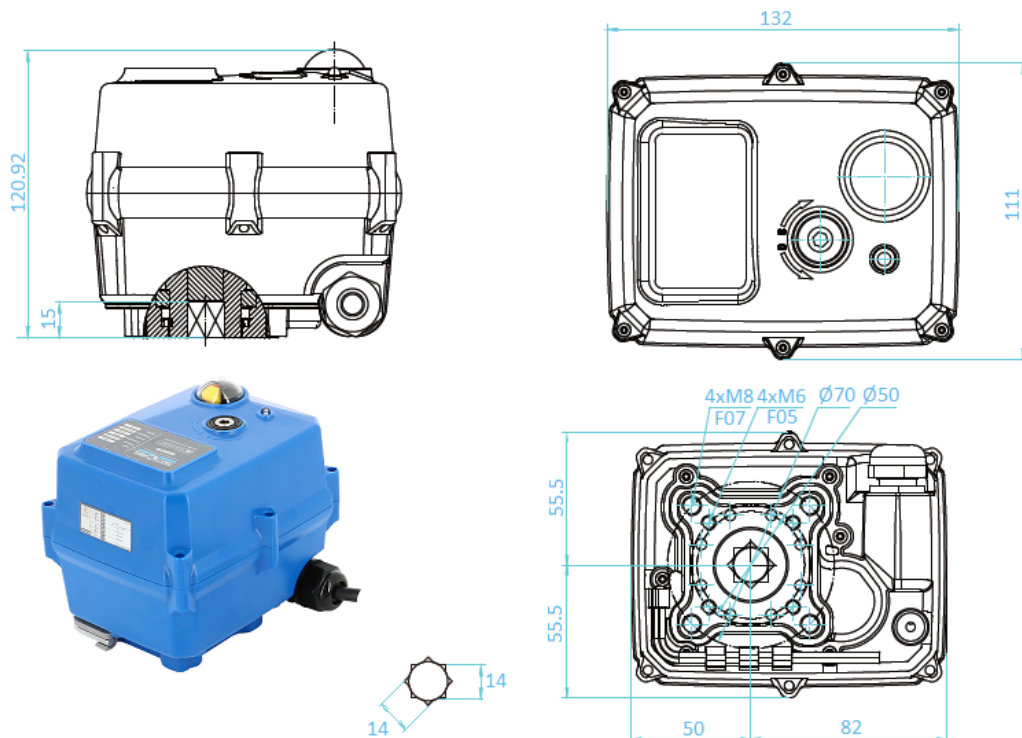

Information given as an indication only, and subject to possible modifications

# TCR-N ELECTRICAL ACTUATOR

## CONSTRUCTION (TCR-11N)

TCR-11N					
No.	Name	Material	No.	Name	Material
1	Casing + lid	Plastic (ABS)	6	Rating plate	PVC
2	Position indicator	Polycarbonate plastic	7	Key support	Plastic (ABS)
3	Screw x 6	Aisi 304	8	Hex key	Steel
4	Backup control stem	Aisi 304	9	X 2Packing gland	Nylon
5	Gasket	NBR	10	Cover gasket	NBR
Weight (kg): 2.200			11	Cable gland unit	Plastic (ABS)

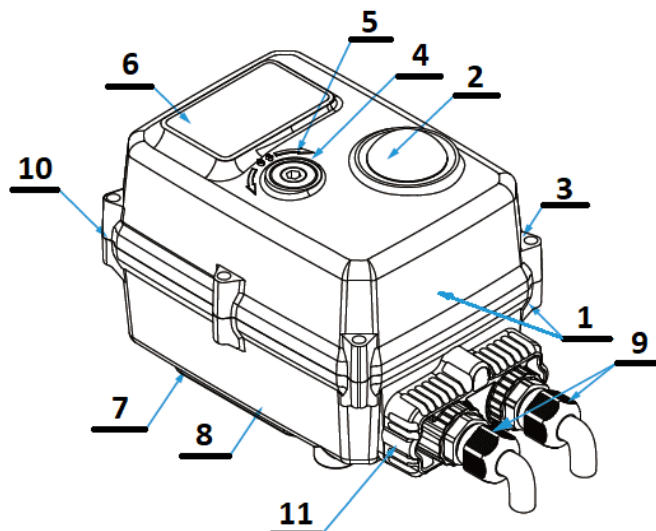

## DIMENSIONS (mm)

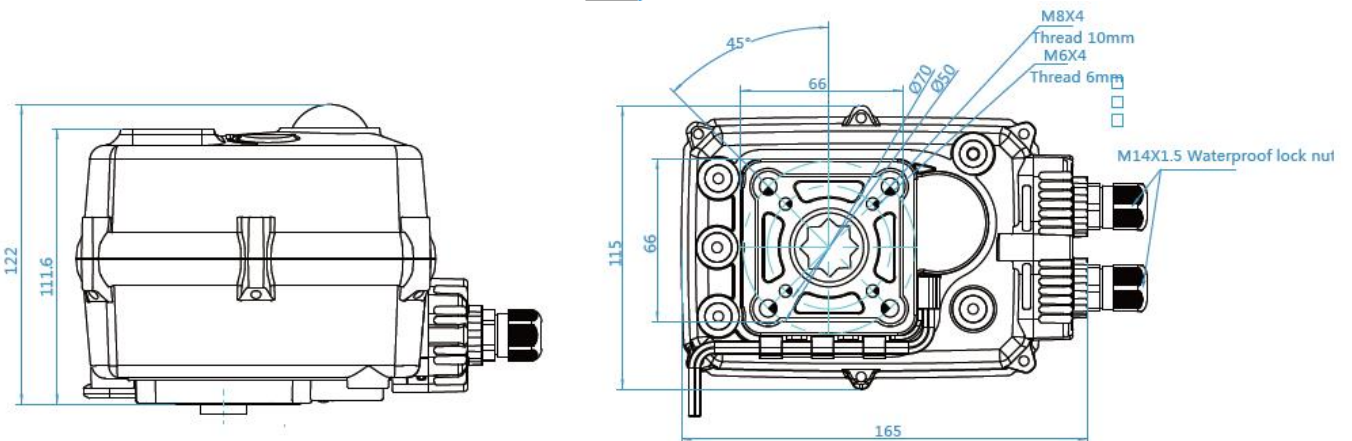

Information given as an indication only, and subject to possible modifications

# TCR-N ELECTRICAL ACTUATOR

## CONSTRUCTION (TCR-20N / TCR-40N)

TCR-20N / TCR-40N					
No.	Name	Material	No.	Name	Material
1	Casing + lid	PC + PET	6	Clutch	Polyoxymethylene POM
2	Position indicator	Polycarbonate plastic	7	Key support	Plastic ABS
3	Screw x 6	Aisi 304	8	Hex key	Steel
4	Backup control stem	Aisi 304	9	X 2Packing gland	Nylon
5	LED	Transparent PC	10	Cover gasket	NBR
Weight (Kg) : 6,000			11	Cable gland unit	Plastic ABS

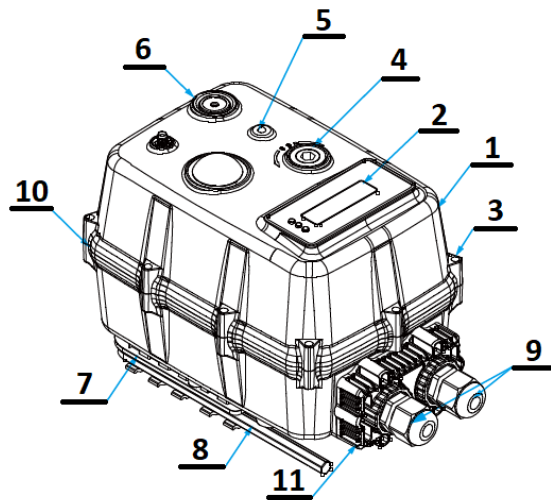

## DIMENSIONS (mm)

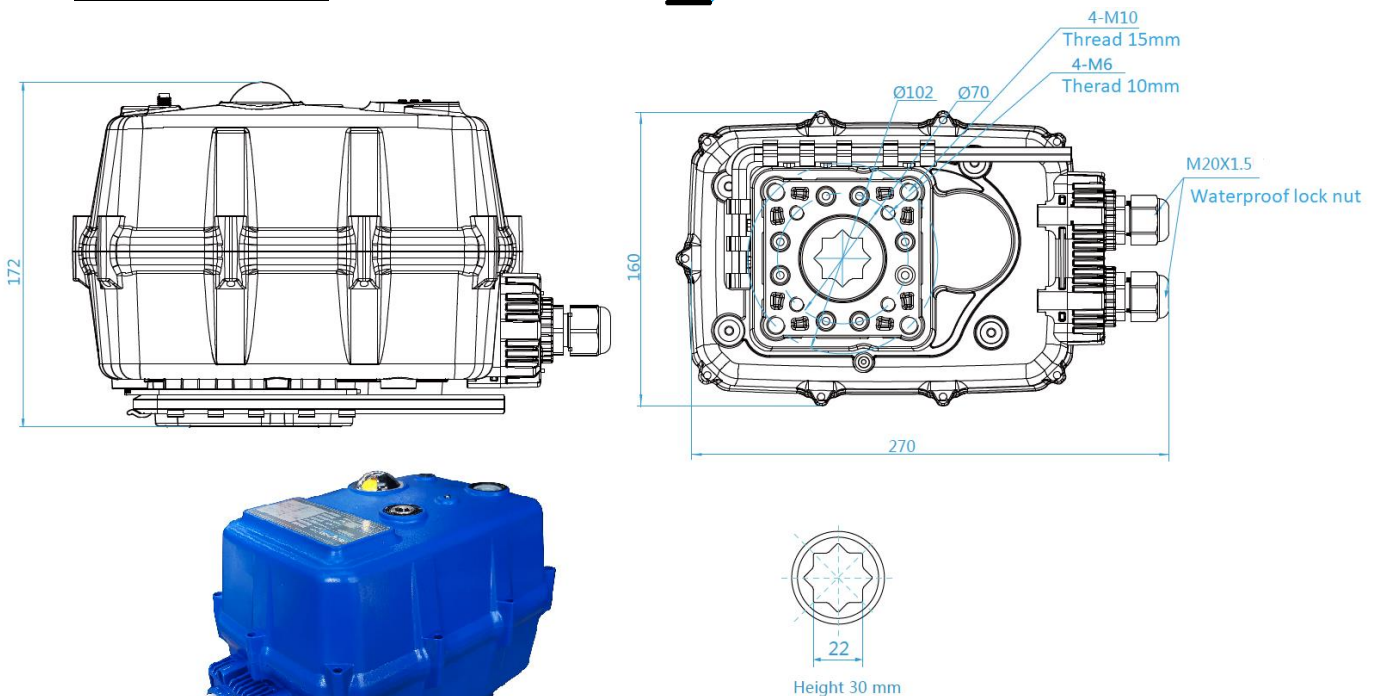

Information given as an indication only, and subject to possible modifications

# TCR-N ELECTRICAL ACTUATOR

## WIRING DIAGRAM

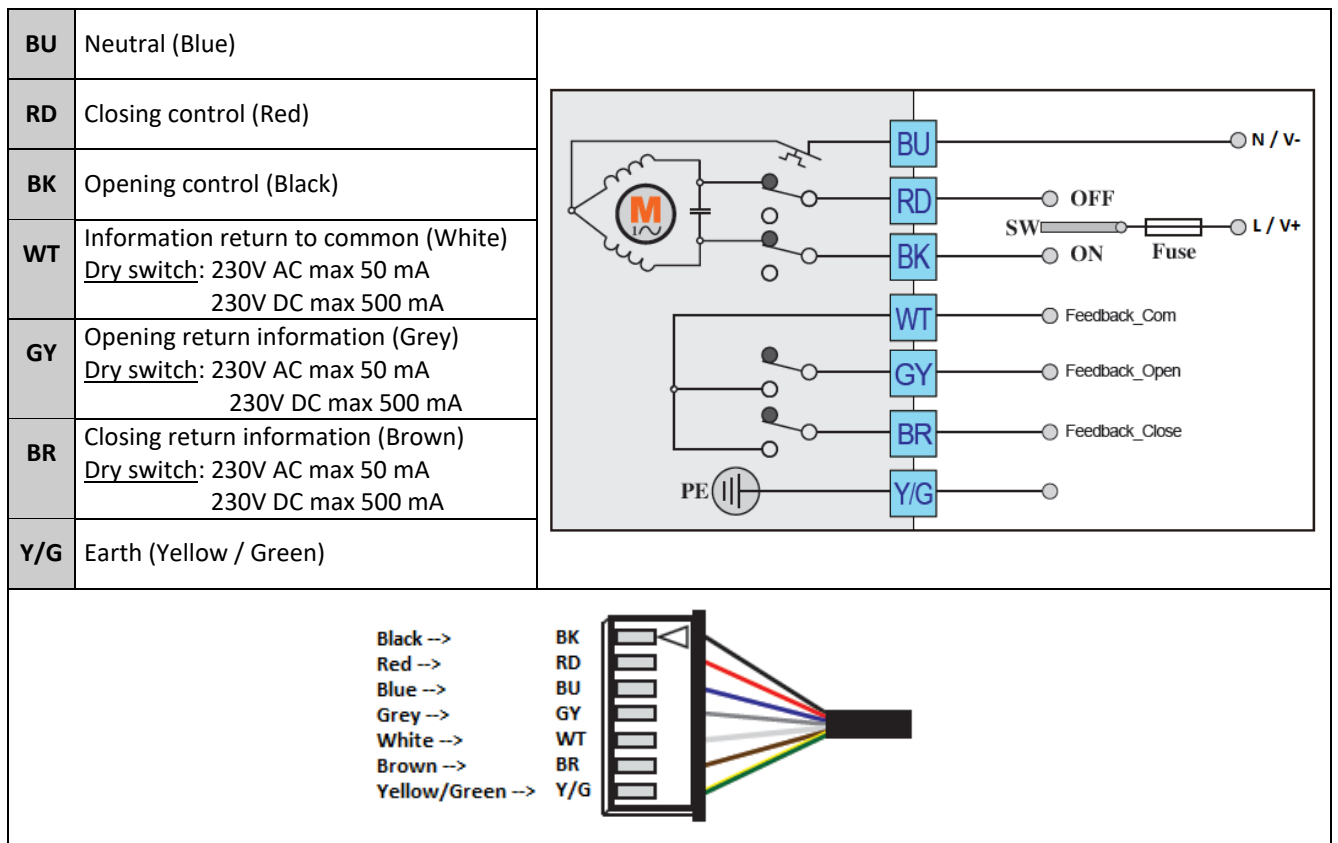

## SWITCH SETTING

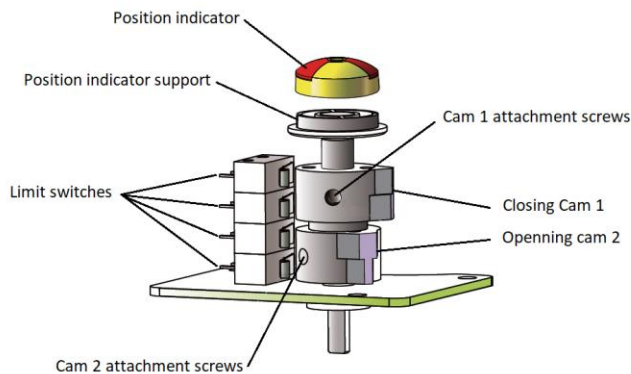

**GENERAL VIEW**

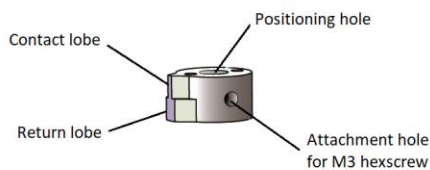

**CAM DETAIL**

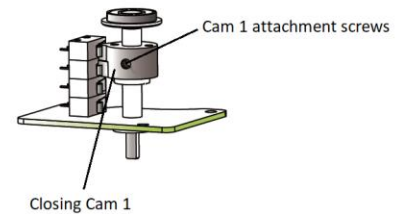

**CLOSING CAM ADJUSTMENT**

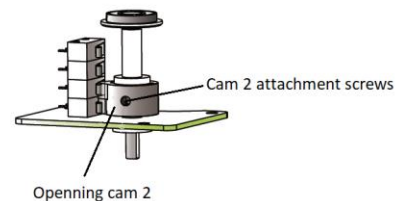

**OPENING CAM ADJUSTMENT**

Information given as an indication only, and subject to possible modifications

# TCR-N ELECTRICAL ACTUATOR

## TROUBLESHOOTING

Defect met	Cause of defect	Method of solving
Inactive actuator	Non-connected electrical grid.	Connect to the electrical grid.
	Wrong voltage.	Check the actuator's voltage.
	Motor overheating.	Check the torque on the valve.
	Faulty connection.	Check the connection to the terminal box.
	Damaged start capacitor.	Contact the supplier for repair.
No switch signal	Faulty connection.	Check the connections.
	Damaged microswitch	Change the microswitch
Valve that is not fully closed	Use the return signal from the actuator check.	Receiving a return signal does not mean that the actuator is fully closed, hence do not cut the power supply.
	The hysteresis increases due to wear or between the actuator and the valve's stem.	Readjust the limit cams. Contact the supplier for repair.
Presence of humidity or water in the actuator	Unsuitable cable cross-section being used.	Contact the supplier for repair.
	The cable connection is not leak-tight.	
	Worn sealing gaskets.	
	Loose cover screws.	Dry the internal parts and tighten the cover screws.

Information given as an indication only, and subject to possible modifications

